

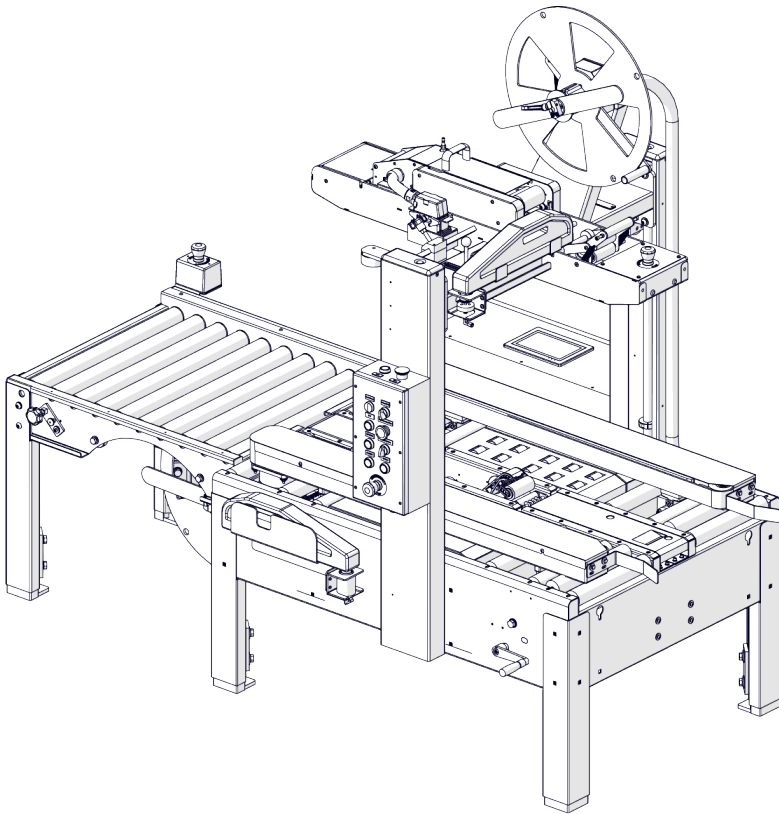

# USER MANUAL USA 2024-WAT

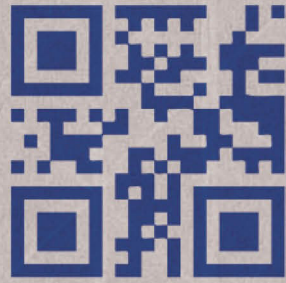

For Serial Numbers:  
TM804 XX X XXX



[www.itape.com](http://www.itape.com)  
800-474-8273

intertape  
polymer  
group<sup>®</sup>



# USER NOTES

---

For all IPG product manuals please visit [www.itape.com/systems-manual](http://www.itape.com/systems-manual) or use this QR code



# TABLE OF CONTENTS

---

<b>Technical Assistance</b>	<b>4</b>
Replacement Parts	4
<b>Field Service Assistance</b>	<b>5</b>
<b>Warranty Information</b>	<b>6</b>
<b>General Information</b>	<b>7</b>
<b>Optional Equipment</b>	<b>8</b>
<b>Important Safeguards</b>	<b>9</b>
<b>Label Placement</b>	<b>10</b>
<b>Safety Label Descriptions</b>	<b>12</b>
<b>Label Descriptions</b>	<b>15</b>
<b>Machine Nameplate</b>	<b>16</b>
<b>Important Safeguards</b>	<b>17</b>
<b>Specifications</b>	<b>19</b>
USA 2024-WAT Dimensions	19
Machine Components	20
Power Requirements	21
Pneumatic Requirements	21
Operating Speed	21
Tape Specifications	22
Operating Conditions	22
Carton Specifications	22
<b>Set-up Procedure</b>	<b>23</b>
Receiving and Handling	23
Set up	23
<b>Connecting Utilities</b>	<b>28</b>
<b>Operator Controls</b>	<b>30</b>
<b>Bottom Tape Head Loading/Threading</b>	<b>31</b>
<b>Top Tape Head Loading/Threading</b>	<b>33</b>
<b>Removing/Replacing The Top Tape Head</b>	<b>35</b>
<b>Removing/Replacing The Bottom Tape Head</b>	<b>36</b>
<b>Adding Water to the System</b>	<b>37</b>
<b>Adjusting the Water Level</b>	<b>38</b>
Adjusting the top water level	38
Adjusting the bottom water level	38
<b>Case Setup Procedure</b>	<b>39</b>
<b>Operating Instructions</b>	<b>41</b>
Carton Jam Clearing	41
HMI Windows and Explanations	42
<b>Preparing Cases to be Processed Continued</b>	<b>45</b>
Flap Folding	45
Over Filled and Void Filled Cartons	45
<b>Operation Modes</b>	<b>46</b>
<b>Troubleshooting</b>	<b>48</b>
Motor Overload	48
Q & A	49
The Machine is Turned on and Nothing Happens	50
Front Tape Leg Not Sticking	51
Rear Tape Leg Not Sticking	52
Tape Does Not Cut	53
Tape Jam	54
Wrinkles in the Tape	55
Tape Not Dispensed	56
<b>Maintenance</b>	<b>57</b>
Lubrication:	57
Cleaning:	57
Recommended Spare Parts:	57
Changing the Air Regulator Filter	58
Drive Belt Adjustment	59
Drive Belt Replacement	60
<b>Appendix A</b>	<b>61</b>
Electrical Drawing	61
Pneumatic Drawing	69
<b>Appendix B</b>	<b>70</b>
Parts Listing	70

# TECHNICAL ASSISTANCE

---

This is the Interpack Model **AUTO H2O Uniform Semi-Automatic-Water Activated Tape (USA 2024-WAT)** Side-Belt Case Sealer you ordered. It has been set up and tested in our factory with IPG manufactured Water Activated Tape. If any problems occur when setting up or operating this equipment, please contact the authorized distributor from where you purchased this item.

If contact with the authorized distributor is not possible, **IPG Machinery Support** is available. Should the need to contact **IPG Machinery Support** arise, **please have the equipment model and serial number available prior to contact**. This information can be found on the nameplate of the tape head as well as on the machine, both sets of information may be necessary to assist. A section at the bottom of this page is available to write this information down. **IPG Machinery Support** is available during normal business hours (M-F 8am-7pm) Eastern Time.

Phone: 813-345-3070

Email: [machsupp@itape.com](mailto:machsupp@itape.com)

## Replacement Parts

A breakdown of parts, including part numbers, can be found in the appendix of this manual. If you know the part number that you require please contact your authorized distributor or IPG Customer Service 877-447-4832 Option 3

Please use this area to enter the detailed information on your Case Sealer and Tape Heads. This should be filled out at the time of install. This information can be found on the nameplate of the machine, typically on the side the operator controls are on. On the WAT Tape Heads serial information can be found near the air intake of the head.

### Machine

Model

Serial

Distributor

Name

Phone/Email

### Tape Head Top

Model

Serial

### Tape Head Bottom

Model

Serial

Date of Purchase

Date of Install

# **FIELD SERVICE ASSISTANCE**

---

Your Interpack Case Sealer and Tape Heads are designed to provide years of trouble free operation. This is not without proper preventative maintenance, a recommended schedule can be located in the maintenance section of this manual, performed by then end user of the equipment. If any problems arise with this machine during the normal course of operation, your properly trained and qualified internal service personnel should be able to repair any issues after consulting the troubleshooting section of this manual in conjunction with phone and/or email support from IPG Machinery Support.

Field Service Support is available from your IPG Authorized Distributor at additional cost if the problem cannot be remedied after consulting the troubleshooting section of this manual.

IPG offers comprehensive programs that help keep your equipment up and running.

Proactive maintenance efforts help to prevent equipment failures and costly emergency repairs. Keeping your machine in optimal working condition also enhances employee safety, reduces facility downtime and efficiently allocates internal resources.

Please contact your IPG Representative to discuss the best options for your IPG equipment.

## **Refurbishment of WAT Tape Heads**

IPG offers a factory repair and refurbishment program. This program will allow end users of IPG WAT Case Sealers to ship their Water Activated Tape Heads back to the factory where trained Factory Technicians will service and repair the tape heads to as close to factory new as possible. To learn more about this program contact your Authorized IPG Representative.

# WARRANTY INFORMATION

---

EQUIPMENT WARRANTY AND LIMITED REMEDY: The following warranty is made in lieu of all other warranties, express or implied, including, but not limited to, the implied warranty of merchantability, the implied warranty of fitness for a particular purpose, and any implied warranty arising out of a course of dealing, a custom or usage of trade:

Intertape sells its Interpack Tape Heads, Case Tapers and Case Erectors with the following warranties:

1. The IPG Pressure Sensitive Tape Heads' knife blades, springs and wipe down rollers will be free from all defects for a period of ninety (90) days.
2. All other IPG Pressure Sensitive Tape Head parts will be free from all defects for one (1) year after delivery.
3. Water Activated Tape Heads' blades will be free from defects for ninety (90) days after delivery.
4. Drive Belts will be free from defects for ninety (90) days after delivery
5. The Gear Motors will be free from defects for one (1) year after delivery.
6. All other components for Case Tapers and Case Erectors will be free from defects for one (1) year after delivery.

If any part is proven defective within its warranty period, then the exclusive remedy and Intertape's and the seller's sole obligation shall be, at Intertape's option, to repair or replace the part, provided the defective part is returned immediately to Intertape's factory or an authorized service station designated by Intertape.

A part will be presumed to have become defective after its warranty period unless the part is received or Intertape is notified of the problem no later than five (5) calendar days after the warranty period.

If Intertape is unable to repair or replace the part within a reasonable time, then Intertape, at its option, will replace the equipment or refund the purchase price. Intertape shall have no obligation to install the repaired or replacement part.

Intertape shall have no obligation to provide or pay for the labor required to install the repaired or replacement part.

Intertape shall have no obligation to repair or replace (1) those parts failing due to: operator misuse, carelessness, or due to any accidental cause other than equipment failure, or (2) parts

1. Failure or damage is due to misapplication, lack of proper maintenance, abuse, improper installation or abnormal conditions such as temperature, moisture, dirt or corrosive matter, etc.
2. Failure due to inadequate cleaning, improper operating environment, improper utilities or operator error.
3. Failure due to operations above the rated capacities, or in any other improper manner, either intentional or otherwise.
4. Failure is due to equipment, which has been altered by anyone other than an authorized representative of Intertape Polymer Group.
5. Failure is due to an attempt by the purchaser to correct alleged defective equipment. In this event the purchaser is responsible for all expenses incurred.

LIMITATION OF LIABILITY: Intertape and seller shall not be liable for direct, indirect, special, incidental or consequential damages based upon breach of warranty, breach of contract, negligence, strict liability or any other legal theory.

The foregoing Equipment Warranty and Limited Remedy and Limitation of Liability may be changed only by written agreement signed by authorized officers of Intertape and seller.

# GENERAL INFORMATION

## Description of USA 2024-WAT

This machine is designed to provide years of trouble free operation. If any problems arise with this machine during the normal course of operation, your properly trained and qualified internal service personnel should be able to repair any issues after consulting the [Troubleshooting](#) section of this manual.

The **USA 2024-WAT** Case Sealer is designed to apply IPG brand water activated tape (WAT) to the top and/or bottom center seam of regular slotted corrugated cartons. The **USA 2024-WAT** Case Sealer manually adjusts to a variety of case sizes.

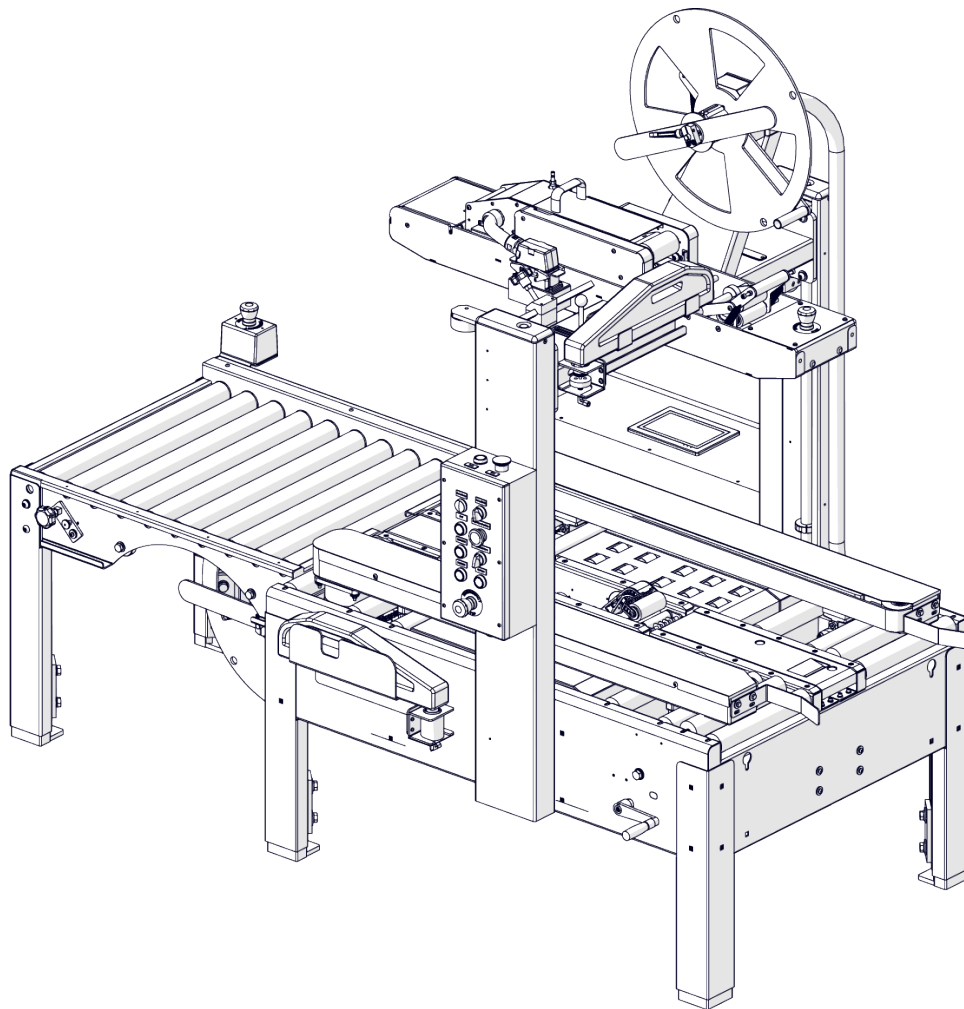

Figure 1: USA 2024-WAT

## Definitions

Common terms that will be used throughout this manual.

**Tape Head** – This will refer to the WAT Top and/or Bottom tape heads for the remainder of this manual

**Case Sealer** – Refers to IPG manufactured Case Sealers

**Machine System** – Refers to the fully assembled Case Sealer with the Tape Head(s) installed

**User/Operator** – The individual who has been trained on the daily use of the Machine System

**Maintenance Champion** – The individual(s) who work for the end user of the Machine System who are responsible for conducting general and preventative maintenance

# OPTIONAL EQUIPMENT

The **USA 2024-WAT** can be outfitted with a variety of optional equipment. The below list is **not** standard and should be discussed with your distributor or authorized IPG representative if you would like them to be added to your machine.

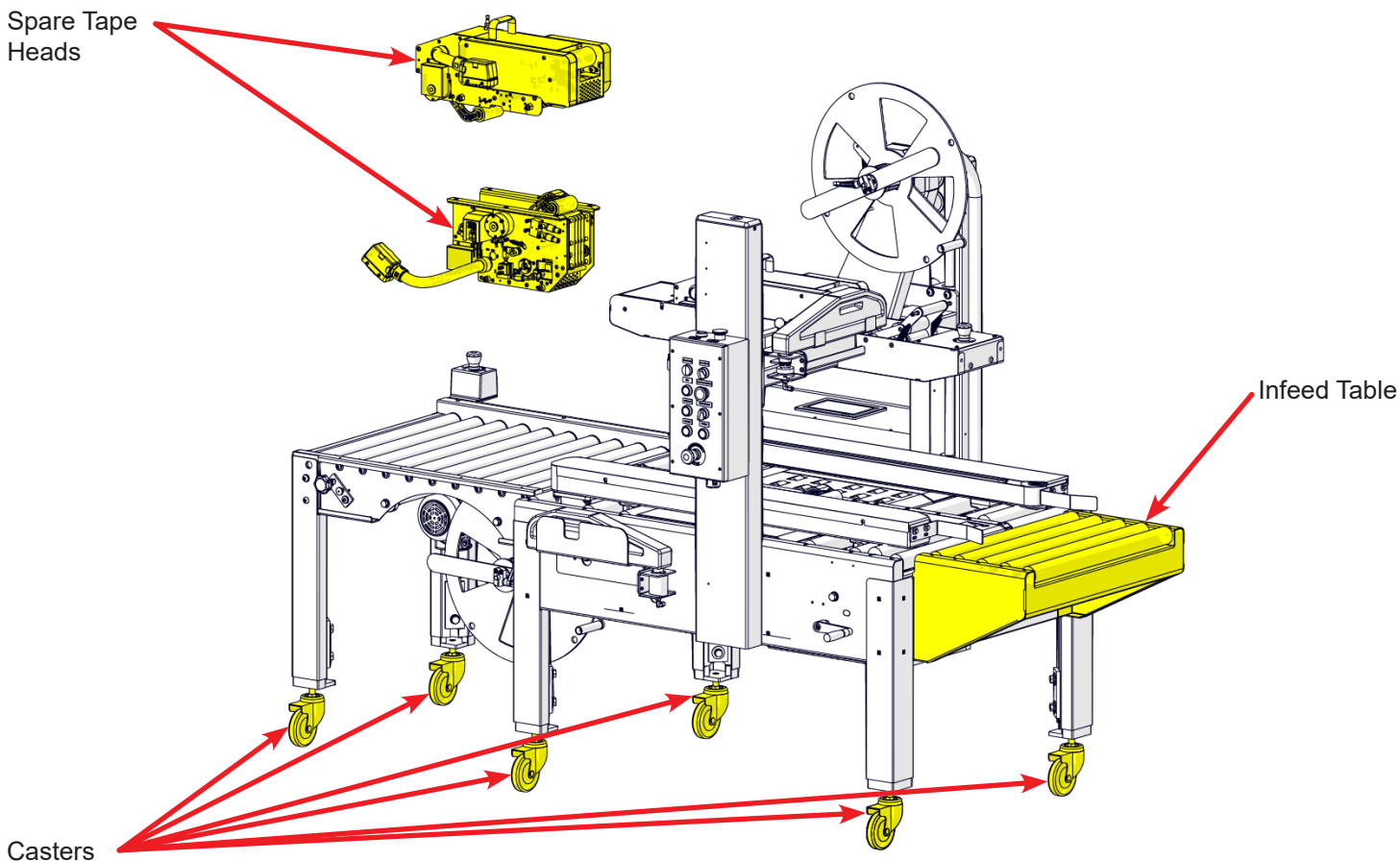

**Figure 2: Optional Equipment**

## Additional Tape Heads

It is recommended to keep a spare top and/or bottom tape head in the event any failure or malfunction causes the machine to stop production. This is to help reduce any possible downtime.

## Can be installed on site

Description	Item Number	Quantity Per Machine
<a href="#">Infeed Table .4M (16")</a>	<a href="#">UM894T</a>	1
<a href="#">Infeed Table .6M (24")</a>	<a href="#">UM998T</a>	1
<a href="#">Infeed Table .9M (36")</a>	<a href="#">UM898T</a>	1
Casters	UM708	1 set of 6 (36" Feed Table will require 2 additional casters)

Description	Item Number
Top WAT Head	UH126TW
Bottom WAT Head	UH125TW
Refurbished Top WAT Head	UH126TWR
Refurbished Bottom WAT Head	UH125TWR

## Cannot be installed on site

The reversal of the electrical cabinet and operator controls is possible but is only recommended to be done at the factory prior to shipment. Additional Emergency-Stop buttons can also be added by the factory prior to shipment.



# IMPORTANT SAFEGUARDS

---

There are a number of safety labels used on the **USA 2024-WAT** Case Sealer. These labels are placed at different locations on the machine to warn operators and service personnel of possible dangers (refer to Figure 3). Please read the labels on the machine and the following safety precautions before using the machine.

**Read this manual for other important safety operating and service information.**

**Only trained personnel are to operate machine.**

**Only fully qualified technicians are to service this machine.**

**Wear safety glasses.**

**Shut off power to machine before adjusting machine or loading & threading Tape Heads.**

**Disconnect electrical power and compressed air (where applicable) before servicing.**

**Follow Lock Out / Tag Out Procedures BEFORE servicing any machinery.**

**All factory installed covers and guards must be in place before operating.**

**Stay clear of moving parts which can shear and cut.**

Should any of the safety labels on the Case Sealer be damaged or destroyed, replacements can be ordered through your distributor.

# LABEL PLACEMENT

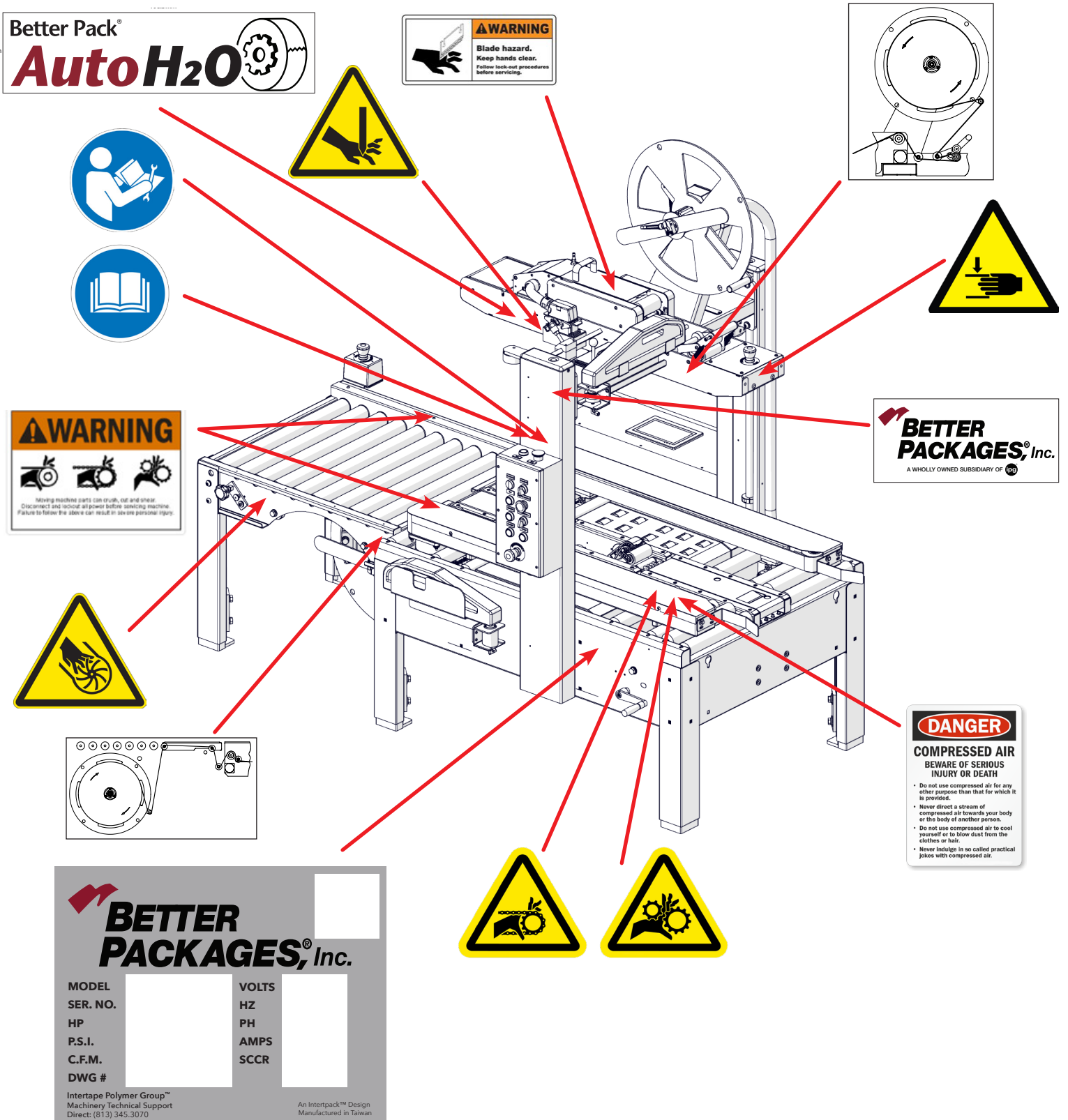

Figure 3: Label Placement 1

# LABEL PLACEMENT

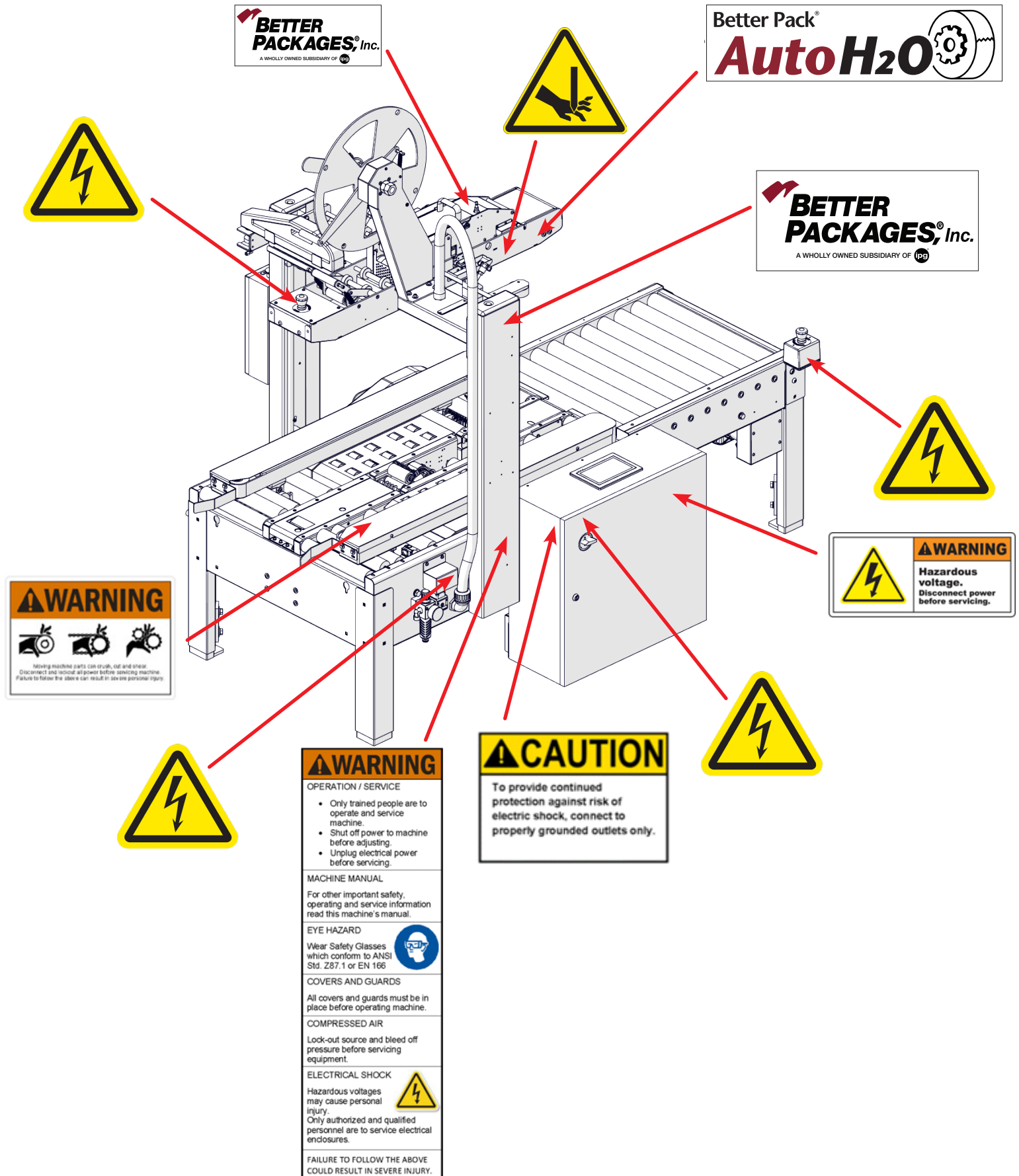







Figure 4: Label Placement 2

# SAFETY LABEL DESCRIPTIONS

<p>The labels shown is affixed to the upper tape head.</p> <p>It warns operators and service personnel of the presence of the cutting blade that may not be visible. Caution should be exercised when approaching this area.</p>	 <p><b>WARNING</b> Blade hazard. Keep hands clear. Follow lock-out procedures before servicing.</p>
<p>The labels shown is affixed to both sides of the bridge frame nearest to the tape head.</p> <p>It warns operators and service personnel of the presence of the cutting blade that may not be visible. Caution should be exercised when approaching this area.</p>	
<p>The label shown is affixed to the upper tape head assembly on either side of the machine.</p> <p>It warns operators and service personnel of a potential crush hazard when cases are moving through the case sealer.</p>	
<p>The label shown is located on the in-feed and exit ends of the machine belt drives and on the powered outfeed table.</p> <p>The label warns the operators and service personnel of the pinch points at each end of the belt drives.</p>	 <p><b>WARNING</b> Moving machine parts can crush, cut and shear. Disconnect and lockout all power before servicing machine. Failure to follow the above can result in serious personal injury.</p>
<p>The label shown is affixed to the electrical control box.</p> <p>The label advises service personnel of live electrical current when the machine is plugged in.</p>	 <p><b>WARNING</b> Hazardous voltage. Disconnect power before servicing.</p>
<p>The label shown is affixed to the electrical control box, and all area where live electrical current is present when the machine is in operation.</p> <p>The label advises service personnel of live electrical current when the machine is plugged in.</p>	

Should any of the safety labels on the Case Sealer be damaged or destroyed, replacements can be ordered through your distributor.

# SAFETY LABEL DESCRIPTIONS CONTINUED

The label shown is located on the side of the column.

This label provides convenient safety instructions for the operator and service personnel in the operation of the IPG Case Sealing Equipment.



Figure 12: Safety Instructions





The label shown is located on the in-feed end of the machine. The label advises personnel about the dangers of the machine due to compressed air used in the system. Be aware of warnings and proper procedures when running and/or servicing the machine.



Figure 13: Compressed Air

Should any of the safety labels on the Case Sealer be damaged or destroyed, replacements can be ordered through your distributor.

# SAFETY LABEL DESCRIPTIONS CONTINUED

<p>The label shown is located on the in-feed and exit ends of the machine belt drives.</p> <p>The label advises operators to keep their hands clear of moving chain components.</p>	 <p><b>Figure 14: Chain Hazard</b></p>
<p>The label shown is located on the in-feed and exit ends of the machine belt drives.</p> <p>The label advises operators to keep their hands clear of moving gear components.</p>	 <p><b>Figure 15: Gear Hazard</b></p>
<p>The label shown is located on the left machine column above the operator control box.</p> <p>The label advises service personnel to read the maintenance instructions thoroughly before conducting any work.</p>	 <p><b>Figure 16: Read Service Manual</b></p>
<p>The label shown is located on the left machine column above the operator control box.</p> <p>The label advises operators to read the user manual thoroughly before operating the machinery.</p>	 <p><b>Figure 17: Read Operator Manual</b></p>

Should any of the safety labels on the Case Sealer be damaged or destroyed, replacements can be ordered through your distributor.

# LABEL DESCRIPTIONS

The labels shown is affixed to both sides of the bridge frame nearest to the tape head.

It is the Better Pack Auto H2O logo.



Figure 18: Auto H2O Logo

The labels shown is affixed to the top of both of the columns.

It is the Better Packages logo.



Figure 19: Better Packages Logo

The labels shown is affixed to the top of the tape head. This is a smaller version of the logo on that is on the machine columns.

It is the Better Packages logo.



Figure 20: Better Packages Logo (tapehead)

The labels shown is affixed to the left side frame of the machine on the infeed side of the operator control box.

It is the Better Packages nameplate for the Auto H2O line of machinery.

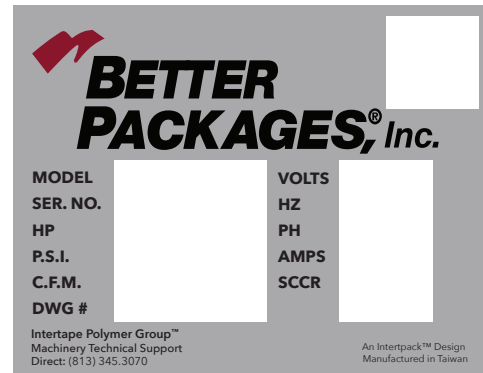
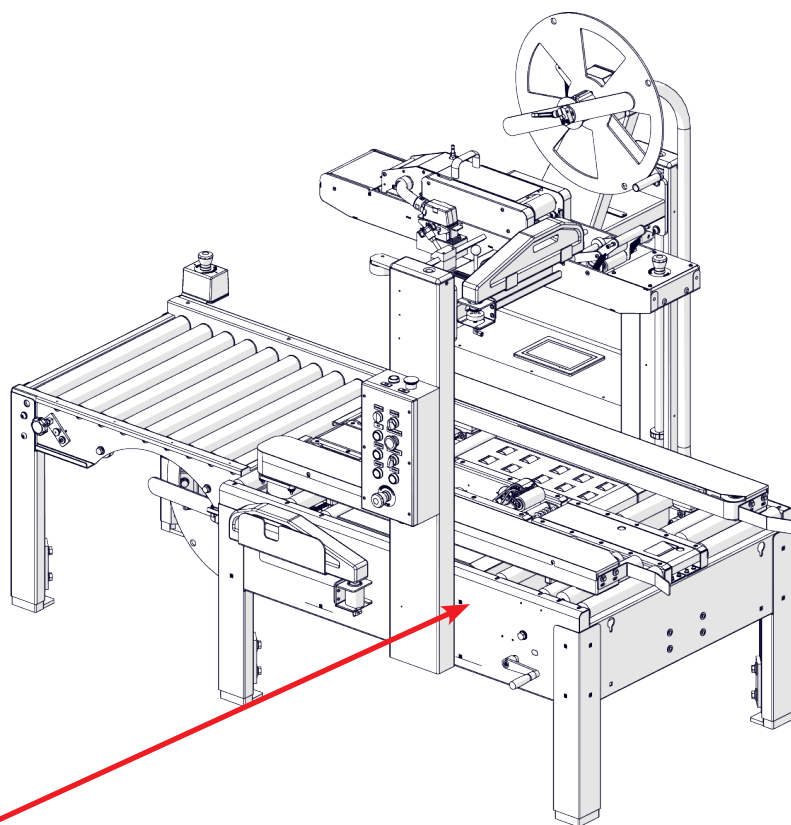

Figure 21: Machine Nameplate

Should any of the safety labels on the Case Sealer be damaged or destroyed, replacements can be ordered through your distributor.

# MACHINE NAMEPLATE



**BETTER PACKAGES<sup>®</sup>, Inc.**

<b>MODEL</b>	USA 2024-WAT	<b>VOLTS</b>	110
<b>SER. NO.</b>	TM13624A001	<b>HZ</b>	60
<b>HP</b>	2x 1/3HP	<b>PH</b>	1
<b>P.S.I.</b>	75 PSI	<b>AMPS</b>	7.6
<b>C.F.M.</b>	9	<b>SCCR</b>	
<b>DWG #</b>			

Intertape Polymer Group™  
Machinery Technical Support  
Direct: (813) 345.3070

An Intertpack™ Design  
Manufactured in Taiwan

Machine Identification and Motor Power

Machine Pneumatic Requirements if applicable

Applicable Machine Drawing Number

Manufacturer Details

Machine Electrical Requirements

Figure 22: Machine Nameplate

## Reading Intertpack Serial Numbers

Model Identifier      Year and Month of Manufacture      Machine Production Number

**TM136**      **24A**      **001**



# IMPORTANT SAFEGUARDS

---

## Explanation of Signal Word Consequences



**WARNING: INDICATES A POTENTIALLY HAZARDOUS SITUATION, WHICH IF NOT AVOIDED COULD RESULT IN DEATH OR SERIOUS INJURY OR PROPERTY DAMAGE**



**CAUTION: INDICATES A POTENTIALLY HAZARDOUS SITUATION, WHICH IF NOT AVOIDED COULD RESULT IN MINOR OR MODERATE INJURY OR PROPERTY DAMAGE**



### **WARNING**

1. **To reduce the risk associated with mechanical, pneumatic, and electrical hazards:**
  - Read, understand, and follow all safety and operating instructions before operating or servicing the Case Sealer and/or Tape Head(s)
  - Allow only properly trained and qualified personnel to operate and service this equipment
2. **To reduce the risk associated with pinches, entanglement, and hazardous voltage:**
  - Turn electrical supply off and disconnect before performing any adjustments, maintenance, or servicing the Case Sealer or Tape Head
3. **To reduce the risk associated with pinches and entanglement hazards:**
  - Do not leave the Case Sealer running while unattended
  - Turn the Case Sealer off when not in use
  - Never attempt to work on any part of the Case Sealer, Tape Head, load tape, or remove jammed boxes from the Case Sealer while the machine is running
4. **To reduce the risk associated with hazardous voltage**
  - Position electrical cord away from foot traffic and vehicle traffic
  - Do not operate the Case Sealer with a damaged power cord
5. **To reduce the risk associated with sharp blades hazards:**
  - Keep hand and fingers away from the tape cutoff blades, the blades are very sharp
6. **To reduce the risk associated with fire and explosion hazards:**
  - Do not operate this equipment in potentially flammable and/or explosive environments
7. **To reduce the risk associated with muscle strain:**
  - Use the appropriate rigging and material handling equipment when lifting or repositioning this equipment
  - Use proper body mechanics when removing or installing Tape Heads that are moderately heavy or may be considered awkward to lift
8. **To reduce the risk associated with mechanical, pneumatic, and electrical hazards:**
  - Allow only properly trained and qualified personnel to operate and service this equipment



### **CAUTION**

1. **To reduce the risk associated with pinch hazards:**
  - Keep hands clear of the upper head support assembly as boxes are transported through the Case Sealer
  - Keep hands, hair, loose clothing, and jewelry away from box compression rollers, moving belts, and Tape Heads
  - Always feed boxes into the Case Sealer by pushing only from the end of the box

# IMPORTANT SAFEGUARDS

## Operator Skill Level Descriptions

These descriptions and levels are uniform across all IPG Case Sealers

### Skill “A” Machine Operator

This operator is trained to use the Case Sealer with the machine controls, to feed cases into the machine, make adjustments for different case sizes (USA series machines), to change tape, to start, stop, and restart production, and to clear jams and perform basic troubleshooting.

**Important:** The end user area supervisor must ensure that the operator has been properly trained on all machine functions before operating the machine.

### Skill “B” Mechanical Maintenance Technician

Also referred to as the Maintenance Champion, this technician, is trained to use the Case Sealer as the Operator is able and in addition is able to work with the safety protection disconnected to check and adjust mechanical components, to perform maintenance operations and repair the Case Sealer. A skill “B” operator is not allowed to work on live electrical components.

### Skill “C” Electrical Maintenance Technician

This technician is trained to use the Case Sealer as the Operator is able and in addition is able to work with the safety protection disconnected, to check and adjust mechanical components, to perform maintenance operations and repair the Case Sealer. A skill “C” operator is allowed to work on live electrical panels, terminal blocks, and control equipment.

### Skill “D” Manufacturer Technician

Skilled technician sent by the manufacturer or its agent (distributors) to perform complex repairs of modifications, when agreed with the customer.

### Operators skill level required to perform the following tasks on the Machine System

OPERATION	MACHINE CONDITION	OPERATOR SKILL LEVEL	NUMBER OF OPERATORS
Tape Roll Replacement	Stopped by pressing the Emergency Stop Button	A	1
Blade Replacement	Electrical Power Disconnected	B	1
Ordinary Maintenance and Preventative Maintenance	Electrical Power Disconnected	B	1
Extraordinary Electrical Maintenance	Running with Safety Protections Disabled	C	1
Extraordinary Mechanical Maintenance	Running with Safety Protections Disabled	D	1
Drive Belt Replacement	Electrical Power Disconnected	B	1
Machine Installation & Set-Up	Running with Safety Protections Disabled	B & D	2

**Proper Electrical Disconnect is achieved when the machine is unplugged from the electrical socket.**

# SPECIFICATIONS

## USA 2024-WAT Dimensions

Machine Weight: 950 lbs. (431kg)

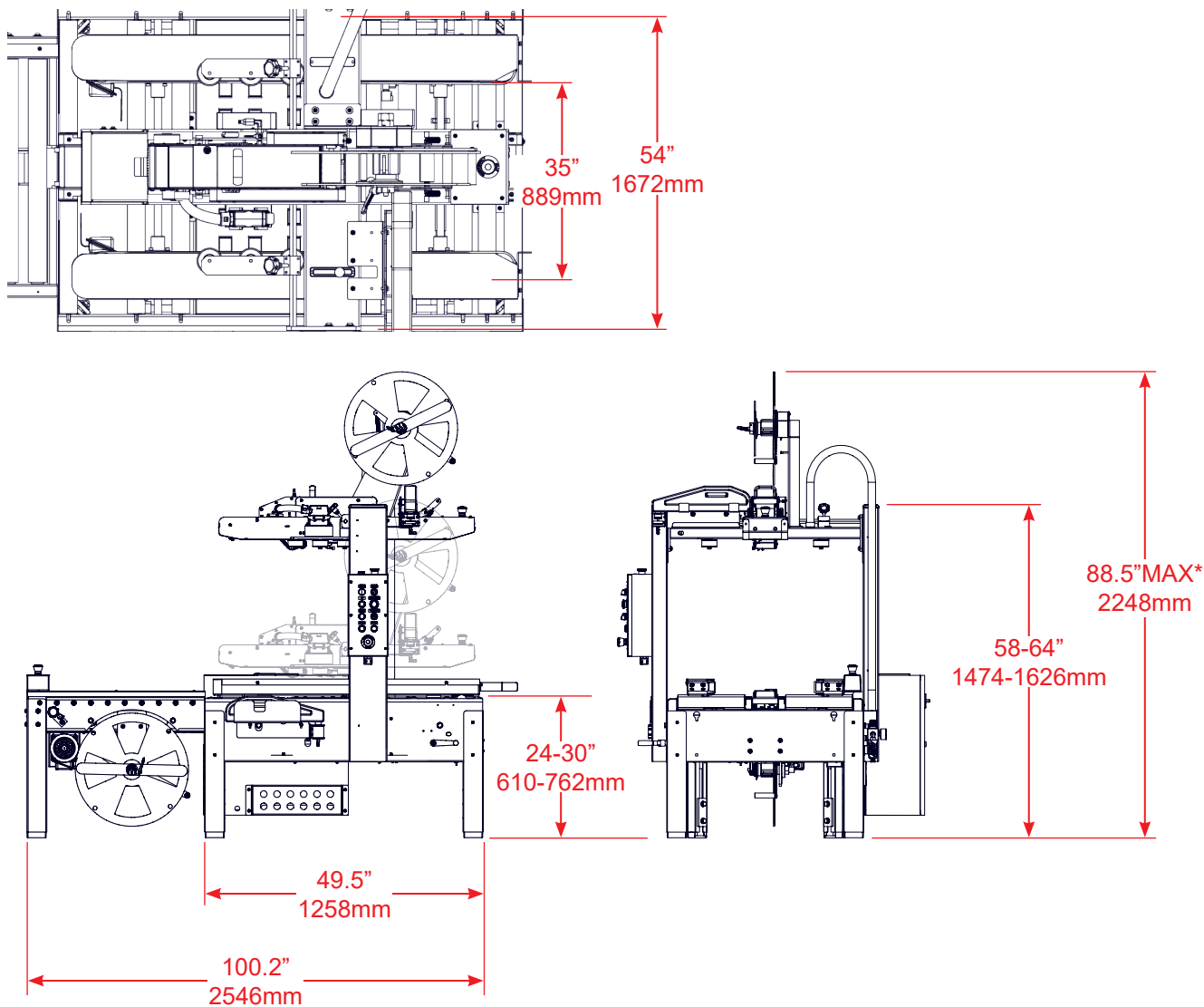

\* Height notated is with standard legs. If a different range is necessary please contact your Authorized IPG Representative for additional conveyor height options. If optional casters are added they will add 4" (102mm) to the conveyor height.

**Figure 23: Machine Dimensions**

# SPECIFICATIONS

## Machine Components

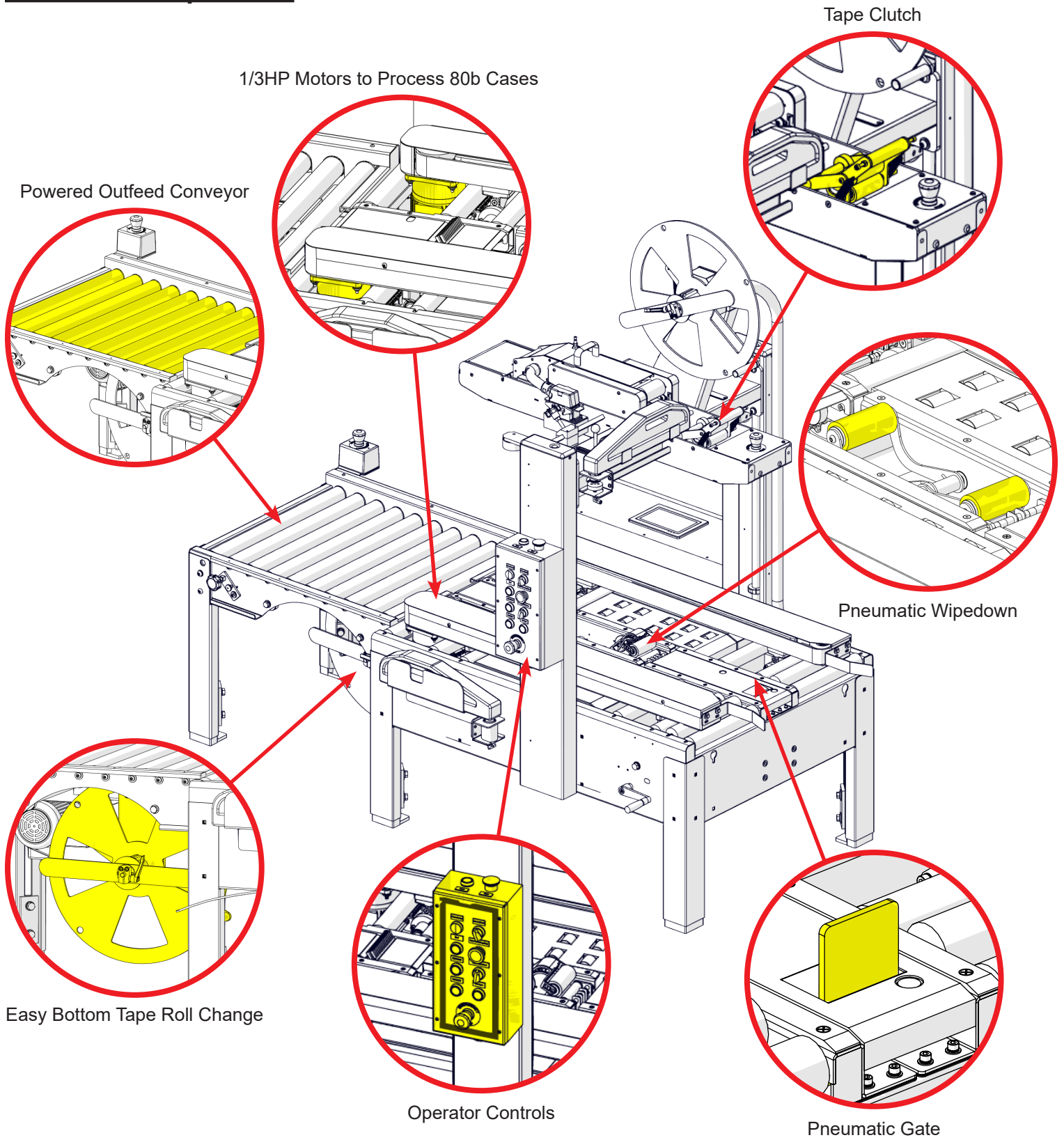

Figure 24: Machine Components

# SPECIFICATIONS

## Power Requirements

Electrical: **110v, 60HZ, 15A (1650 Watts)**

This machine comes standard with three gear motors, one on each drive base and one powered outfeed conveyor, an electrical box, and a control box.

The electrical box contains a HMI for machine adjustments. The control box contains the **Clear** button, **Power Lamp**, a **Manual/ Auto** switch, a **Tape Threading/Stop** button, a **Tape Cut** button, a **Tape Feed** button, an **Emergency Stop** switch, a **Start** button, and a **Reset** button.

A 12 ft. (3.6 m) standard, three-conductor power cord with plug is provided for **110V, 60HZ, 15A** service. The receptacle providing this service **must** be properly grounded and installed by a licensed electrician.

## Pneumatic Requirements

Compressed Air Supply: 9CFM at 90 PSI (28.3 Liter/min at 620.5 kPa)

This machine comes standard with one main regulator. This regulator should be set to a maximum of 75 PSI (512.1 kPa).

Air must be clean and dry. If moisture enters the system valves can begin to degrade and lines slowly clog. This can cause reduced flow resulting in undesired machine behavior. If moisture is detected in the air lines an in-line air dryer may be used. IPG does not supply in-line air dryers.

## Operating Speed

Belt speed is 82 ft./min (24.9 m/min). Boxes must be separated by 14 in. (356mm).

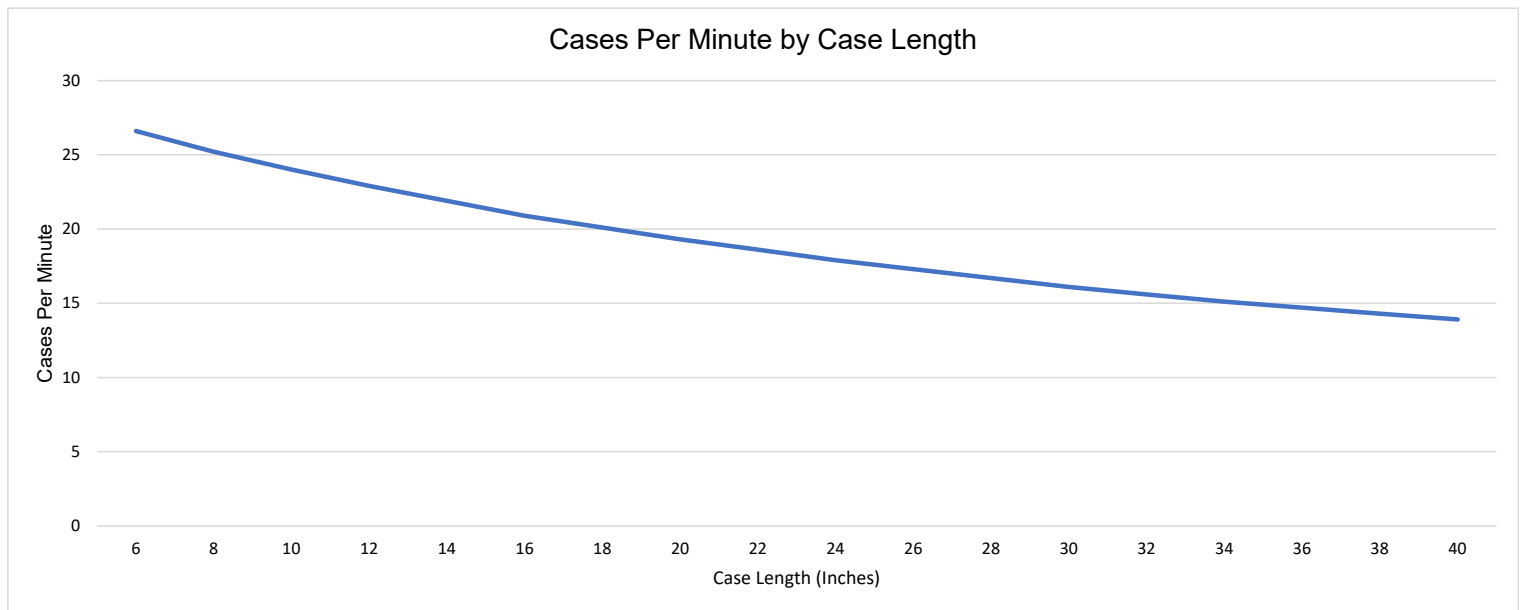

**Figure 25: Cases Per Minute**

# SPECIFICATIONS

## Tape Specifications

Use only **IPG Water-Activated Tape**. The machine can accommodate tape widths of 3 in. (70 - 75mm).

A maximum tape roll length of 4500 ft. (1371.6m) can be installed on the tape heads. This machine can accommodate all IPG brand, water-activated tape within listed specifications.

The standard tape leg length of 3 in. (75mm) is factory set. The standard tape leg length may vary up to ¼ in. (6mm) based on tape tension and line speed.

The standard tape leg length is adjustable via the HMI on the electrical box. The minimum tape leg length recommended is 2 in. (48mm) and the maximum recommended is 3 in. (75mm).

## Operating Conditions

Use in a dry, relatively clean environment at 40° to 105° F (5° to 40° C) with clean dry cartons. Maximum sound pressure level is less than 70dBA.



**CAUTION: MACHINE SHOULD NOT BE WASHED DOWN OR SUBJECTED TO CONDITIONS CAUSING CONDENSATION ON COMPONENTS. FOLLOW CLEANING INSTRUCTIONS.**



**CAUTION: TO PREVENT INJURY KEEP AN AREA WITH A MINIMUM OF 36 IN. (915MM) OF SPACE CLEAR, CLEAN, AND DRY ON THE OPERATOR AND CONTROL BOX SIDES OF THE MACHINE.**

## Carton Specifications

### Type

- Regular Slotted Containers (RSC)
- Other styles may be processed. Consult factory.

### Material

- 125 to 175 PSI bursting test, single or double wall, B or C flutes
- Other styles may be processed. Consult factory.

### Weight

- 0 to 38.5 kg (0 to 85 lbs.) Max

### Size

Carton Size	Length	Width	Height
Minimum	7" (178mm)*	7" (178mm)*	3" (77mm)
Maximum	Infinite	20" (508mm)	24" (610mm)

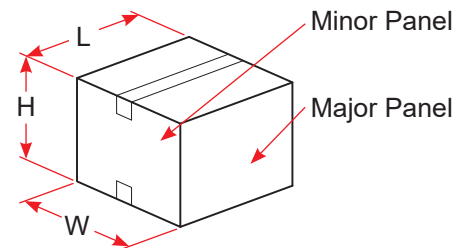

However, if the box length (in the direction of the seal) to box height ratio is 0.75 or less, several boxes should be test run to assure proper machine performance. The formula is as follows:

$$\frac{\text{Carton Length in direction of seal}}{\text{Carton Height}} > 0.75$$

# SET-UP PROCEDURE

## Receiving and Handling

The Interpack **USA 2024-WAT** is shipped to the customer in a box and fixed to a pallet. The machine is enclosed with either a corrugated sleeve and cap or an HSC corrugated box. The sequence below is step by step instructions to remove all packing materials.

### **PRIOR TO SIGNING FOR THE MACHINE INSPECT IT FOR ANY DAMAGE THAT MAY HAVE OCCURRED DURING SHIPPING**

1. Remove the strapping and/or staples at the bottom of the box
2. Lift the box cover off of the machine, use caution and team lift
3. Remove any bubble wrap or protective wrapping
4. Inspect the machine for any damage that may have occurred during shipping
5. Remove the mounting bolts and nuts that secure the machine to the pallet
6. Using a forklift or other lifting device, lift the machine off the pallet
  - Install any optional casters at this point as well as adjusting leg height for desired conveyor height
7. Position the machine in its desired location
8. Remove any remaining tie wraps and shipping materials
9. Install the included Carton Retainers
10. Install any optionally ordered equipment

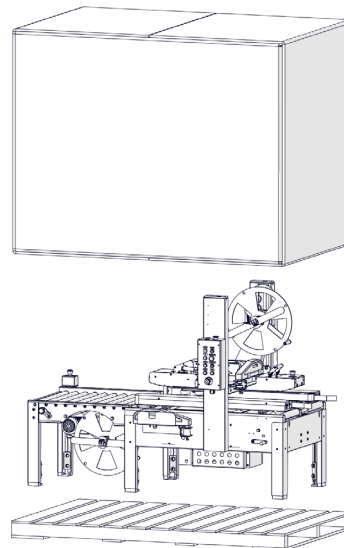

**Figure 26: Unboxing**

After unpacking the Case Sealer, look for any damage that may have occurred during shipping. Should the Case Sealer be damaged, file a claim with the transport company and notify your IPG representative as soon as possible.

## Set up

The Case Sealer must be installed on a near level ground. Use the adjustable legs to ensure the machine is level and firmly planted on the ground (no rocking). Adjust the leg height with the six (6) telescopic adjustment legs to accommodate conveyor heights from 24 in. to 30 in. Consult with the factory for any other conveyor heights that may be required. Optional Casters add 4 in. to the conveyor height. If noted in the purchase order the case sealer can be shipped pre-configured for the desired conveyor height.

To adjust the Case Sealer height, jack up the machine to give ample room to extend the legs. Using a 19mm box end wrench, loosen the eight (8) M12mm hex bolts. Adjust the legs to the desired conveyor height and tighten the bolts. Etched lines on the legs ease leveling. The machine must be properly supported prior to any leg adjustment.

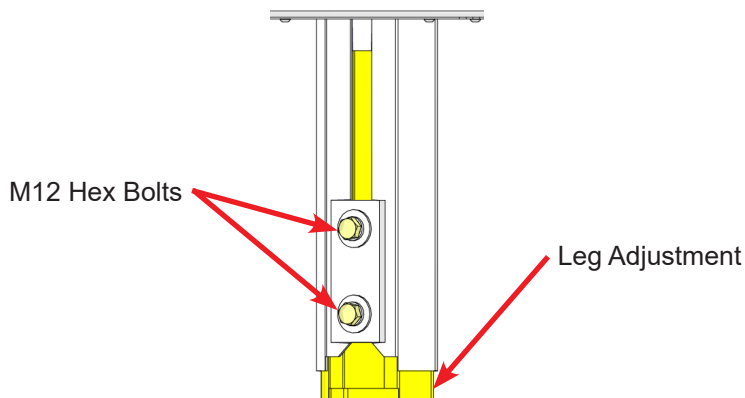

**Figure 27: Leg Adjustment**

Customer supplied exit conveyor (if used) should be straight and declined no more than 1 in./yard (5 cm/meter) away from the Case Sealer to convey the sealed cartons away from the machine.

# SET-UP PROCEDURE

## Optional Equipment: Caster Installation



**WARNING: CASTER INSTALLATION REQUIRES RAISING THE MACHINE TO ACCESS THE BOTTOM OF EACH LEG. FOLLOW ALL POSSIBLE SAFETY PROCEDURES PRIOR TO AND DURING THIS PROCESS.**

Be advised there are several ways to install the casters on IPG Case Sealers. Consult your company's safety practices after reading through the below directions. Take all precautions necessary.

1. Raise the machine to allow access to the bottom of each leg.
2. By hand, screw the caster into each leg.
3. Using a wrench, verify each caster is firmly seated to the bottom of the legs.
4. Lower the machine back down until it is resting on the casters.
5. Adjust the legs as necessary to achieve proper level of the machine.



**CAUTION: DO NOT ADJUST THE HEIGHT USING THE CASTERS. HEIGHT CHANGES ARE TO ONLY BE MADE BY ADJUSTING THE LEG EXTENSIONS.**

6. Position the machine in its desired location.
7. Lock the casters.

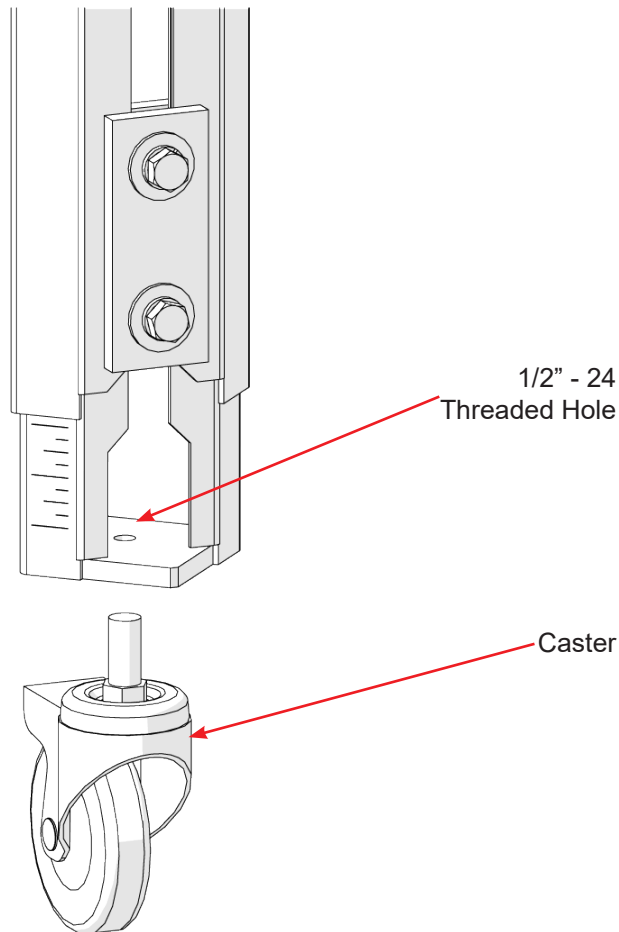
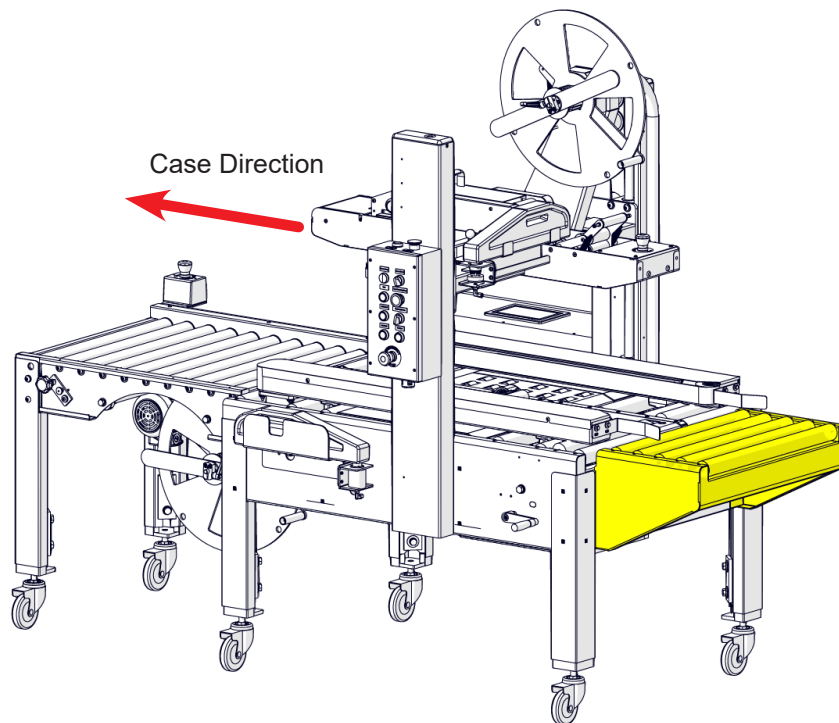

**Figure 28: Caster Installation**



# SET-UP PROCEDURE

## Optional Equipment: Infeed Table Installation

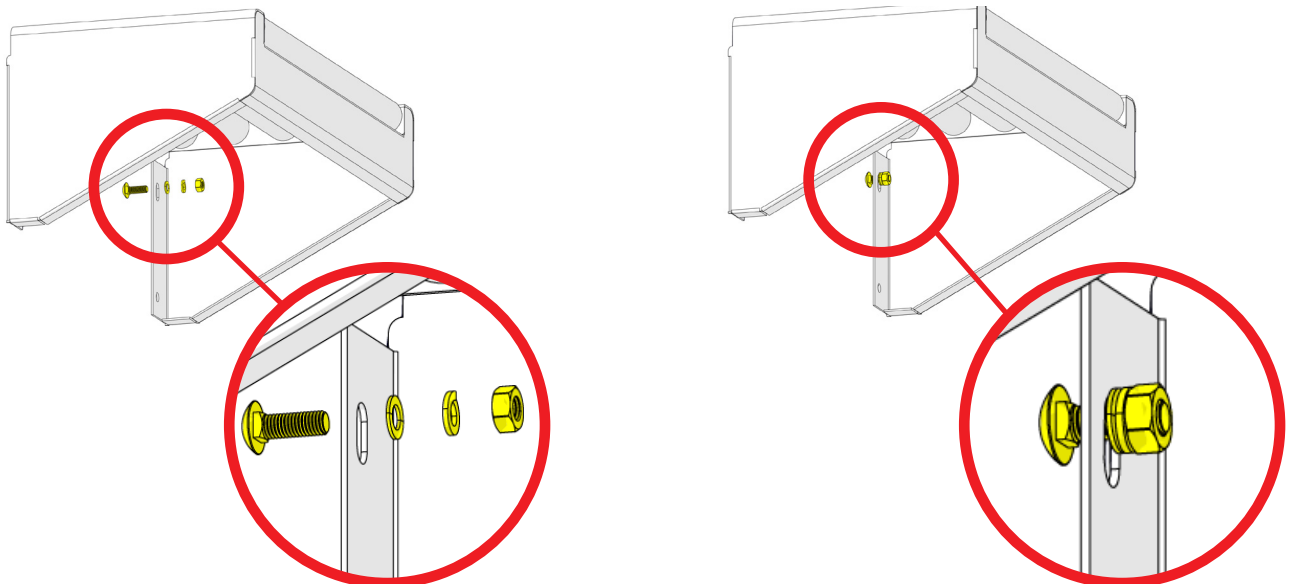

**Figure 29: Case Direction**

The USA 2024-WAT can only accept an Infeed Table. Where a traditional Outfeed Table would be mounted a powered outfeed table comes standard.

IPG Case Sealers come with the necessary mounting points for in-feed tables. The optional in-feed tables will come with all necessary hardware to mount to the machine. The case sealers can accept a variety of table sizes. Please consult with the factory on the best size table for your application.

1. Loosely install two carriage bolts into top two mounting holes on roller table with hardware included.

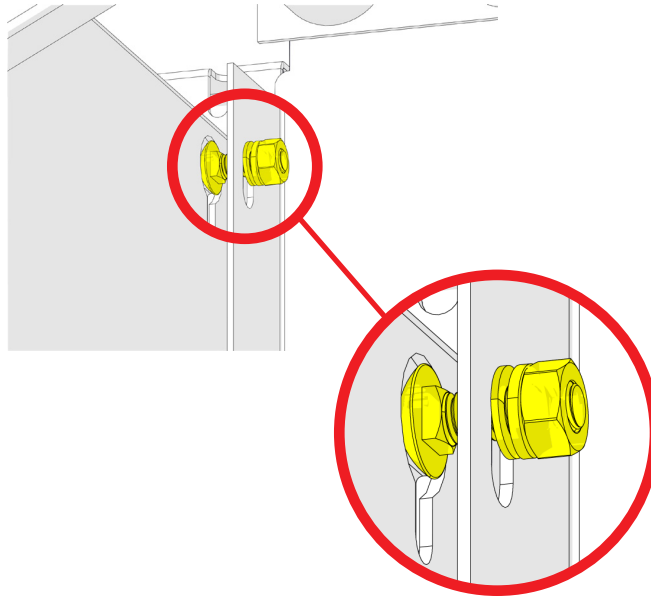

**Figure 30: Carriage Bolt Assembly**

# SET-UP PROCEDURE

## Optional Equipment: In-feed Table Installation (Continued)

1. Utilizing the slots on the machine base, attach roller table to machine base by locating carriage bolts in slots on machine base and push down to lock in place. Make sure carriage bolts are properly aligned into the slot when pushed down to lock in place before proceeding.



**Figure 31: Table to Machine Base Installation**

2. Once roller table is attached to the machine base using the two carriage bolts, install remaining two carriage bolts with hardware included through the bottom two holes on the machine base and roller table.
3. After all four mounting studs and included hardware have been installed, tighten all hardware to avoid roller table instability then install rollers on table.

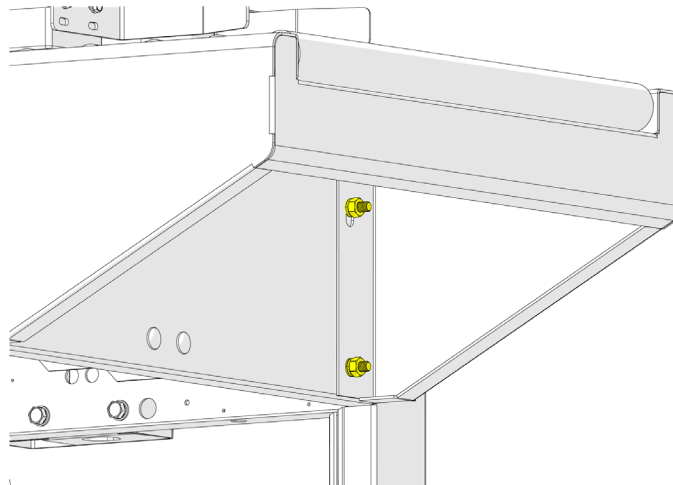

**Figure 32: Remaining Carriage Bolt Installation**

# SET-UP PROCEDURE

## Optional Equipment: Installation of External In-feed and Exit Conveyors

IPG does not supply conveyors. All conveyors are to be customer supplied.

1. Customer supplied gravity exit conveyor (if used) should be straight and declined no more than 1 in./yard (5 cm/meter) away from the machine to convey the sealed cartons away from the machine.
2. Customer supplied powered exit conveyor should be straight and level to convey the sealed cartons away from the machine.

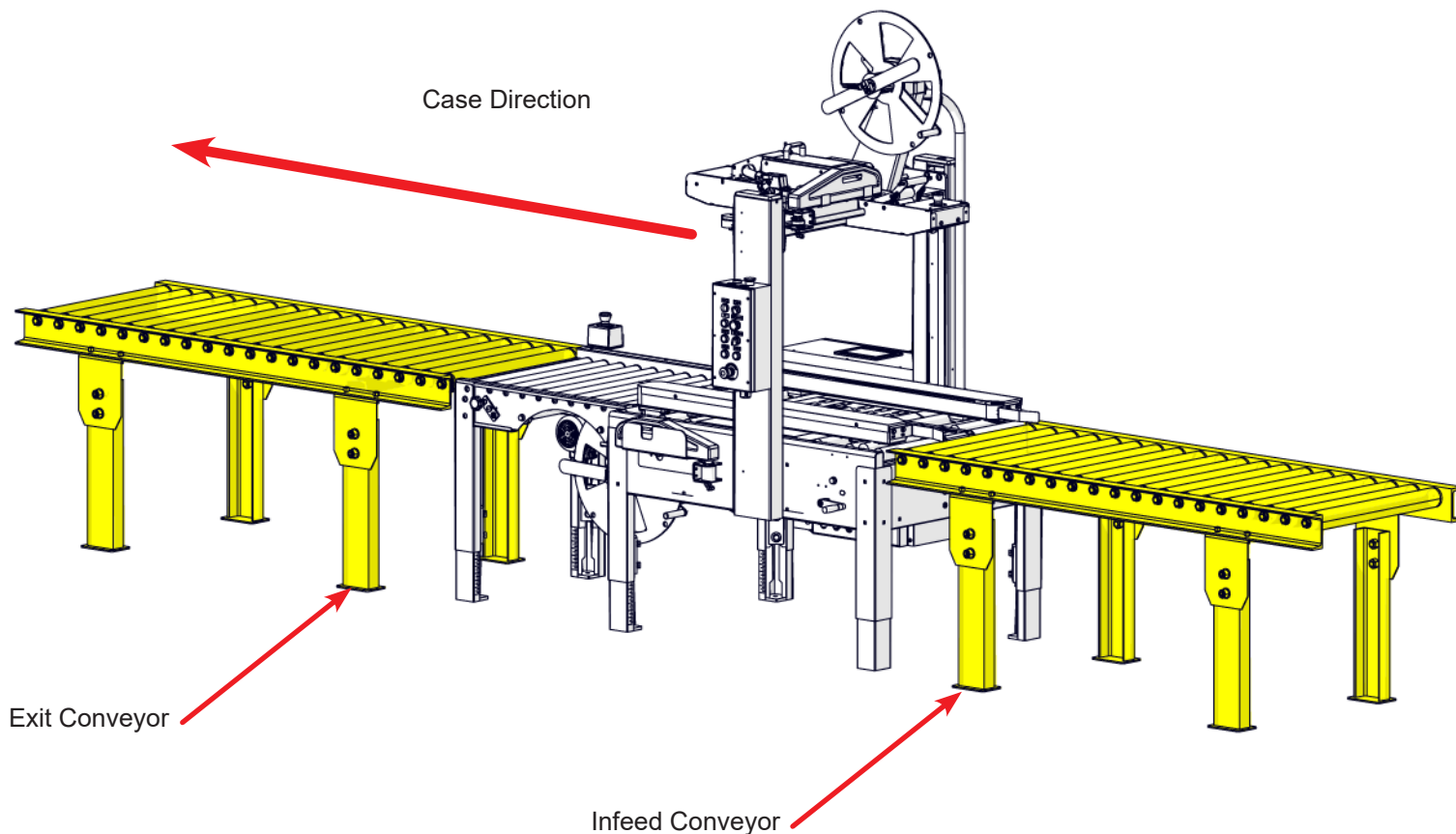

**Figure 33: Installing Exit Conveyors**

# CONNECTING UTILITIES

## Electrical Utilities

A 12 ft. (3.6m) standard three-conductor power cord with plug is provided for **110V, 60HZ, 15A** electric service. The receptacle must be properly grounded. Before the machine is plugged into the receptacle, ensure that all materials are removed from the machine. The electrical control is protected with an automatic circuit breaker with resettable overload and fuses. Do not use an extension cord or power-strip.

The electrical box is located on one side of the **USA 2024-WAT** Case Sealer. It also contains the HMI that is used for some basic controls and altering machine settings.

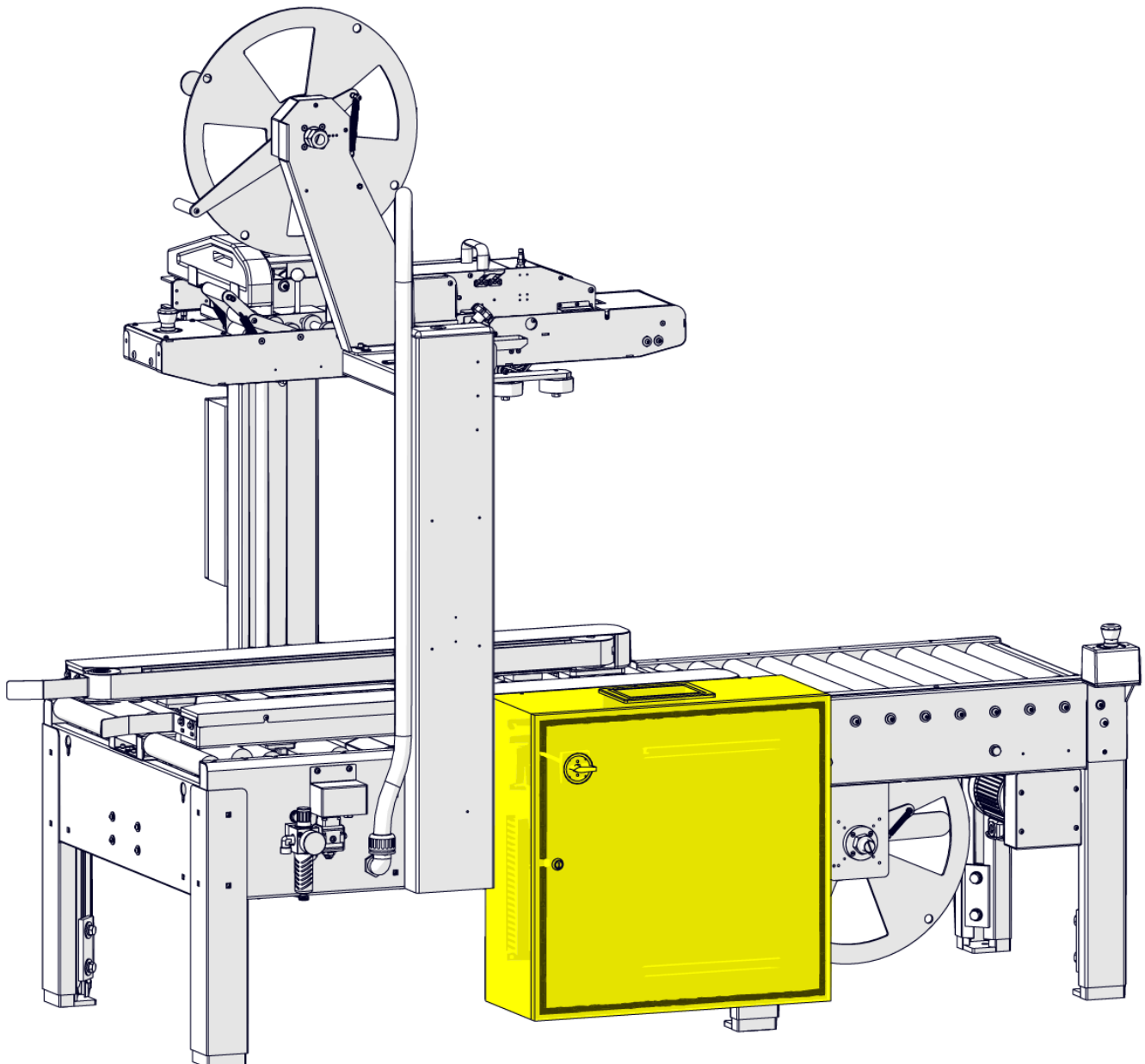

**Figure 34: Electrical Utilities**

The electrical box and pneumatic input can be reversed but this is recommended to be done at the factory.

# CONNECTING UTILITIES

## Pneumatic Utilities

The pressure setting for the main air regulator is factory set. The values will need to be adjusted as needed by customer supplied pressure and volume.

The main air regulator has a male quick disconnect adapter. Connect clean dry compressed air to this adapter. The **USA 2024-WAT Case Sealer** requires a minimum of **9 CFM at 90 PSI** (28.3 Liter/min at 689 kPa). It is connected to an electronic dump valve prior to any connection into the machine.

To regulate the main air pressure, pull on the knob located on the top of the main air regulator. Turn the knob clockwise for more pressure and counterclockwise for less. When the air pressure is at 75 PSI, push back down on the button until a “click” is felt to lock it in position. The thread size is 3/8 in NPT.

Should the supplied airline or pressure be unplugged, cut, or pressure drop for any reason, tape will not feed and rollers will not be activated if box is processed.

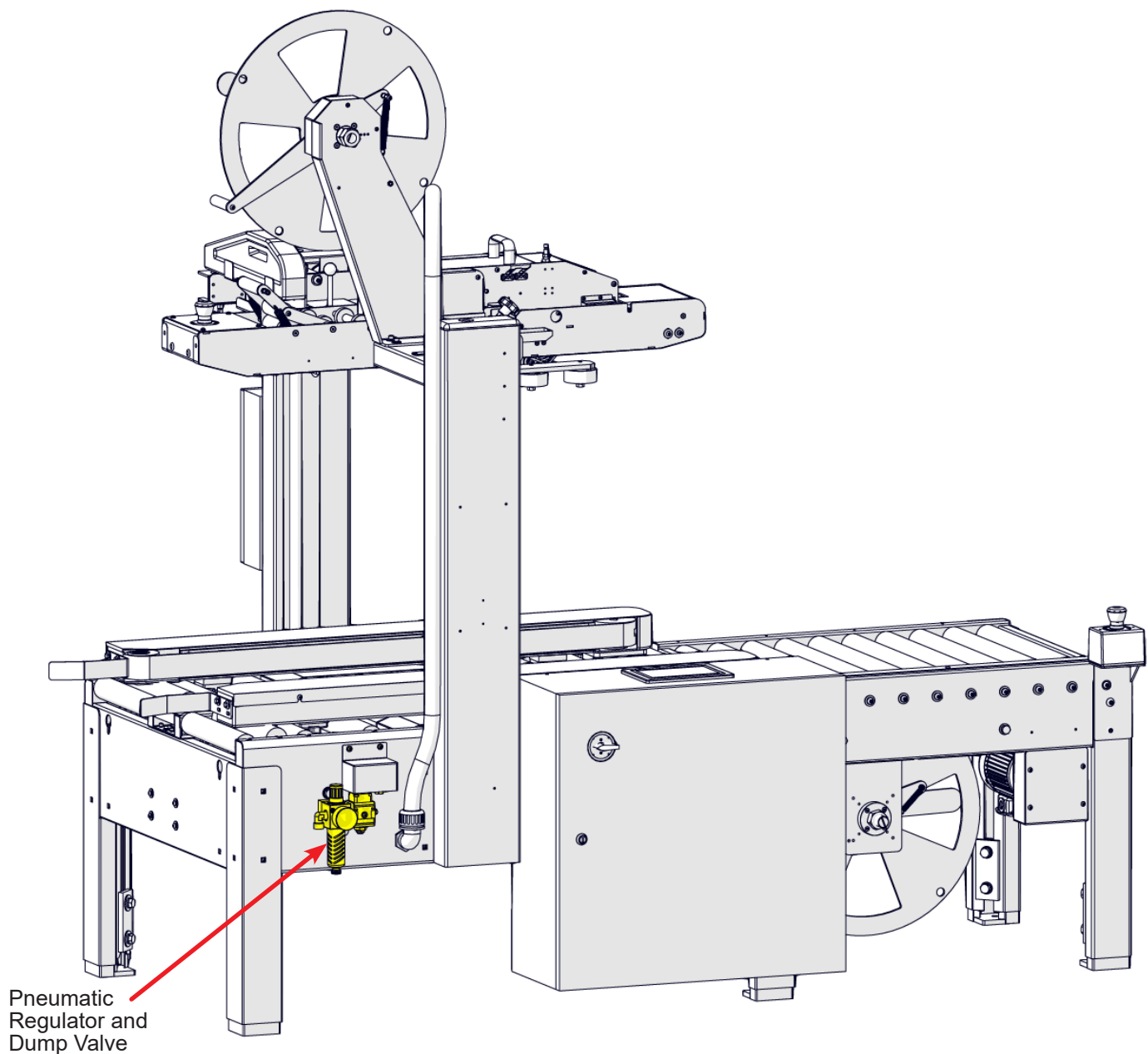

**Figure 35: Pneumatic Utilities**

# OPERATOR CONTROLS

Make sure machine is connected to air supply of at least 90 PSI (660.5 kPa) and machine regulator is set at 75 PSI. The following describes the use of control box buttons:

- 1. Reset button** - Used to reset machine after power up or to reset after all E-Stops have been cleared.
- 2. Clear button** (Operational in Auto Mode only). This button is used to simplify clearing a jam during production. When pressed down, belt drive motors stop, air supply is dumber, and cutting mechanism is engaged if tape was dispensed.
- 3. Manual/Auto switch**
  - Auto mode is for normal machine operation.
  - Manual mode is for tape threading/troubleshooting.
- 4. Tape Threading/Stop button**
  - In Auto Mode, stops machine operation.
  - In Manual Mode, engages/disengages pinch roller which drives the tape.
- 5. Tape Cut button**
  - No function in Auto Mode.
  - In Manual Mode, engages cutting mechanism in tape head to cut tape.
- 6. Emergency Stop button**
  - In Auto Mode, de-energizes machine.
  - In Manual Mode, de-energizes machine.
- 7. Tape Feed button**
  - No function in Auto Mode.
  - In Manual Mode, feeds a length of tape and cuts it.
- 8. Belt Drive button**
  - No function on Auto mode.
  - In Manual mode, press and hold to engage belt drive, release to stop.
- 9. Start button**
  - In Auto mode, starts machine.
  - No function in Manual mode.
- 10. Power Lamp** - Illuminated when power is being delivered throughout the machine.

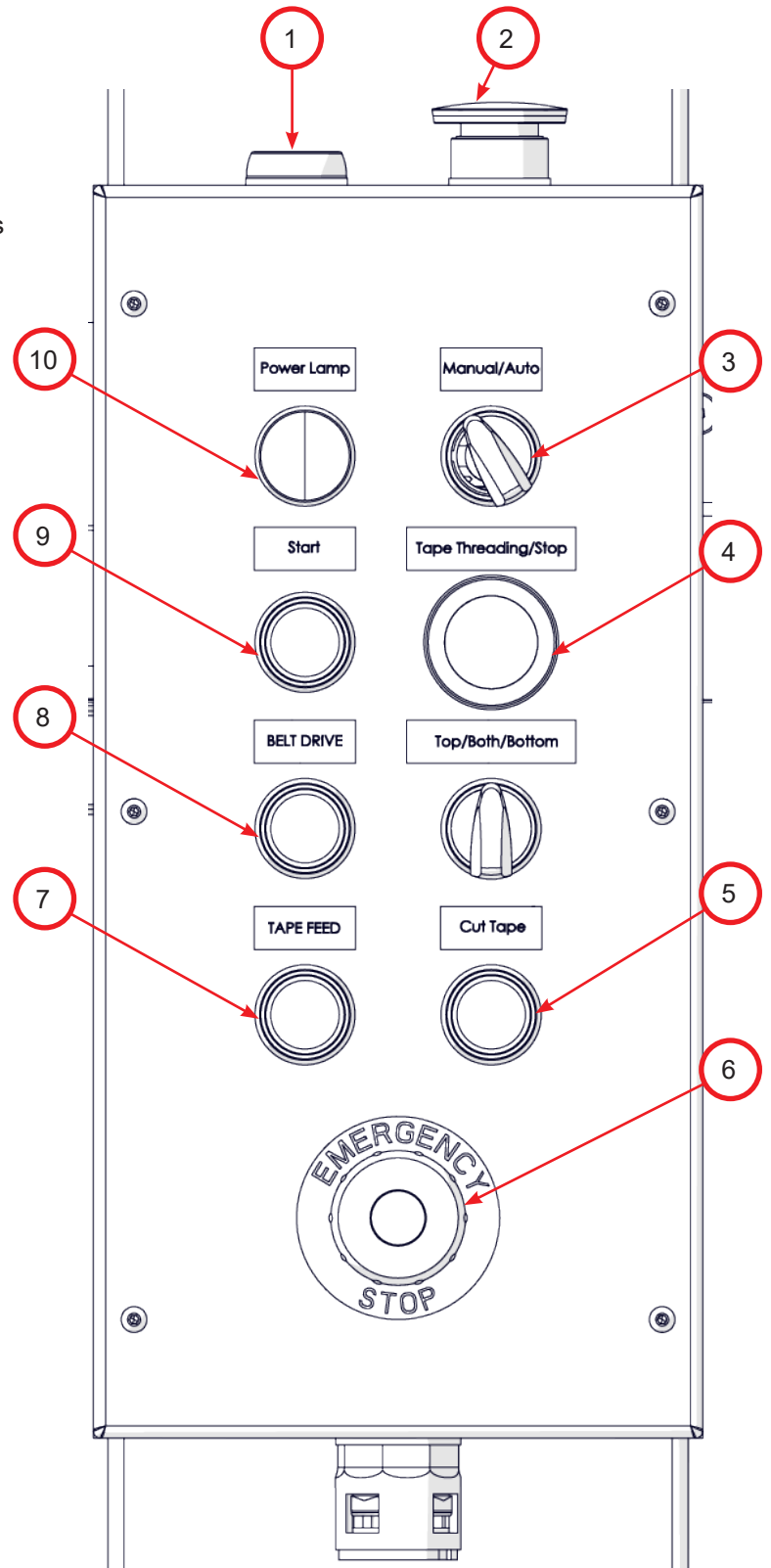

Figure 36: Operator Controls

# **BOTTOM TAPE HEAD LOADING/THREADING**

## **Direction of Bottom Tape Unwind**

As shown in the diagram below, tape should be mounted with a clockwise, unwind direction. The adhesive side of tape will be facing down as it goes around the peel-off roller.

## **Bottom Tape Path**

The diagram below shows the threaded tape path using the red line/arrow as the tape. For proper threading of tape use the steps in the next section. The order in which the tape passes the rollers starts at the peel-off roller, travels through three guide rollers, as labeled below, then over powered roller, and under a fourth guide roller.

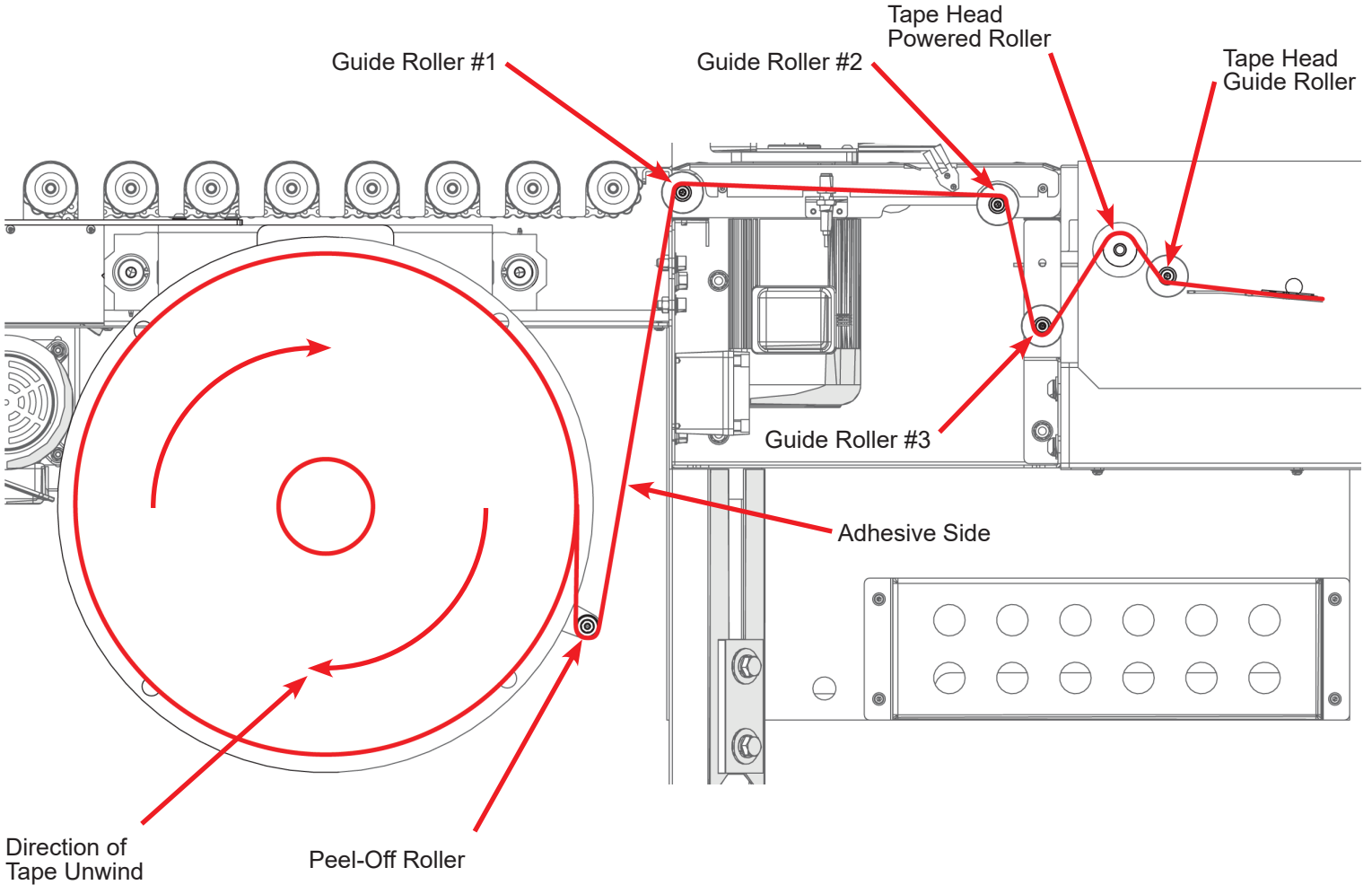

**Figure 37: Bottom Tape Path**

# BOTTOM TAPE HEAD LOADING/THREADING

## Bottom Tape Loading/Threading Instructions

The instructions below will assist in threading tape on the bottom tape head. Bottom Threading diagram is located on page 30.

1. Put machine in Manual Mode using Manual/Auto selector switch (Item 1).
2. Press the Tape Threading Button (Item 2).
3. Unlock the tape carriage retaining bracket and pull it out away from the machine (Item 3). When fully extended lock the bracket to prevent unwanted movement of the bottom tape mandrel.
4. Loosen the handle on the tape mandrel and remove the Cross Bar Assembly (Item 4).
5. Remove the old tape core and any remaining tape in the tape path.
6. Install a new roll of tape. The tape peel-off direction should be clockwise.
7. Peel back the tape and have it go under the Peel-off Roller (Item 5).
8. Unlock the tape carriage and while holding the end of tape in one hand push the tape carriage back to its home position and lock the carriage in place (Item 3).
9. Slip the tape up between the machine frame and the first powered roller. Grasp it with your free hand on the top side of the powered conveyor (Item 6).
10. Remove the rear cover to expose the tape guide rollers.
11. Pull the tape over the two (2) guide rollers (#1 and #2) (Item 7)(Some models may have a clutch roller).
12. The tape must then pass under the #3 guide roller (Item 9) before being pulled up over the first roller in the tape head (Item 9).
13. At this time, use scissors to trim any of the damaged tape off allowing for a clean edge.
14. After being pulled over the powered tape head roller pass the tape under the tape head guide roller (Item 10).
15. Lastly make sure the tape is under the tape head pinch roller and the top tape plate (Item 11).

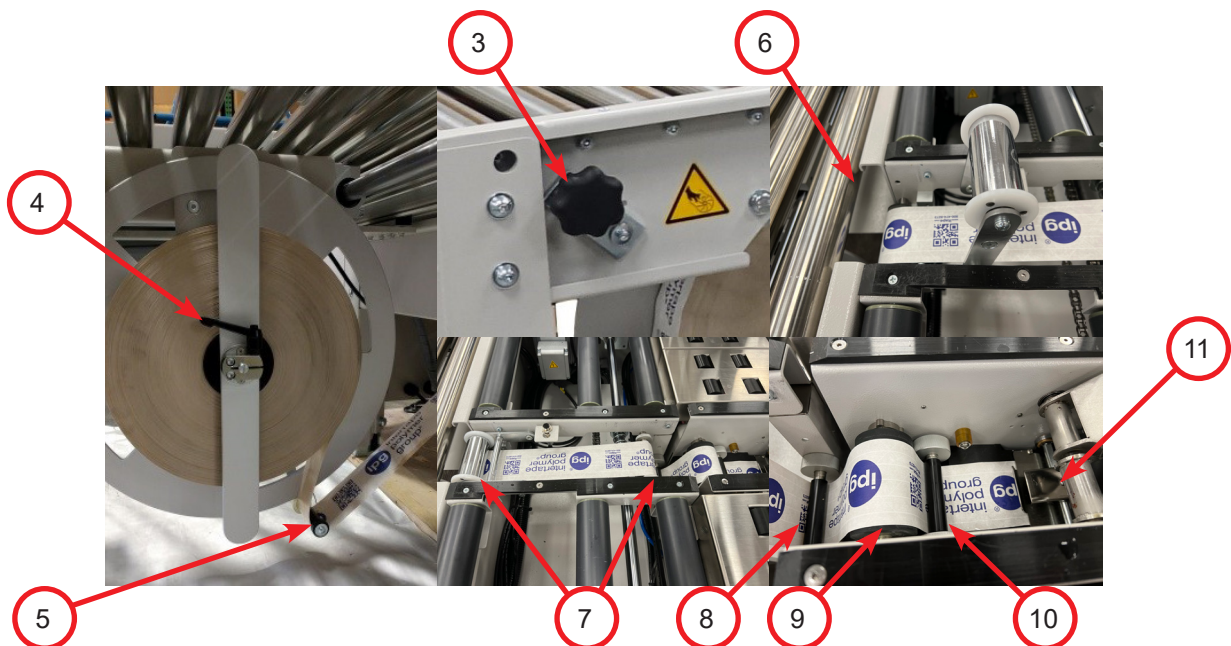
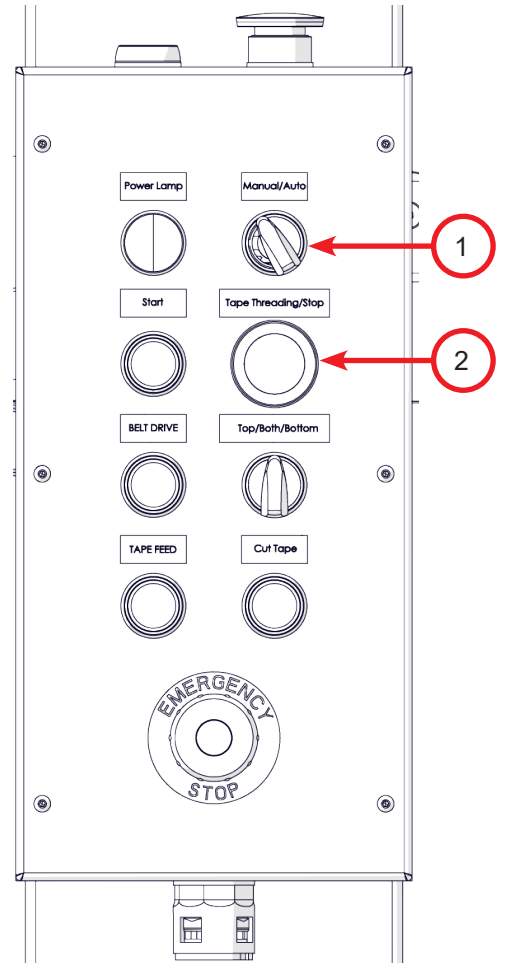

**Figure 38: Bottom Tape Loading Procedure**



# TOP TAPE HEAD LOADING/THREADING

## Direction of Top Tape Unwind

As shown in the diagram below, tape should be mounted with a counterclockwise, unwind direction. The adhesive side of tape will be facing up as it goes around the peel-off roller.

## Top Tape Path

The diagram below shows the threaded tape path using the red line/arrow as the tape. For proper threading of tape use the steps in the following section. The order in which the tape passes the rollers starts at the peel-off roller, travels under the center roller, through the clutch roller, under the third roller, over the tape head powered roller, finally under the tape head pinch roller.

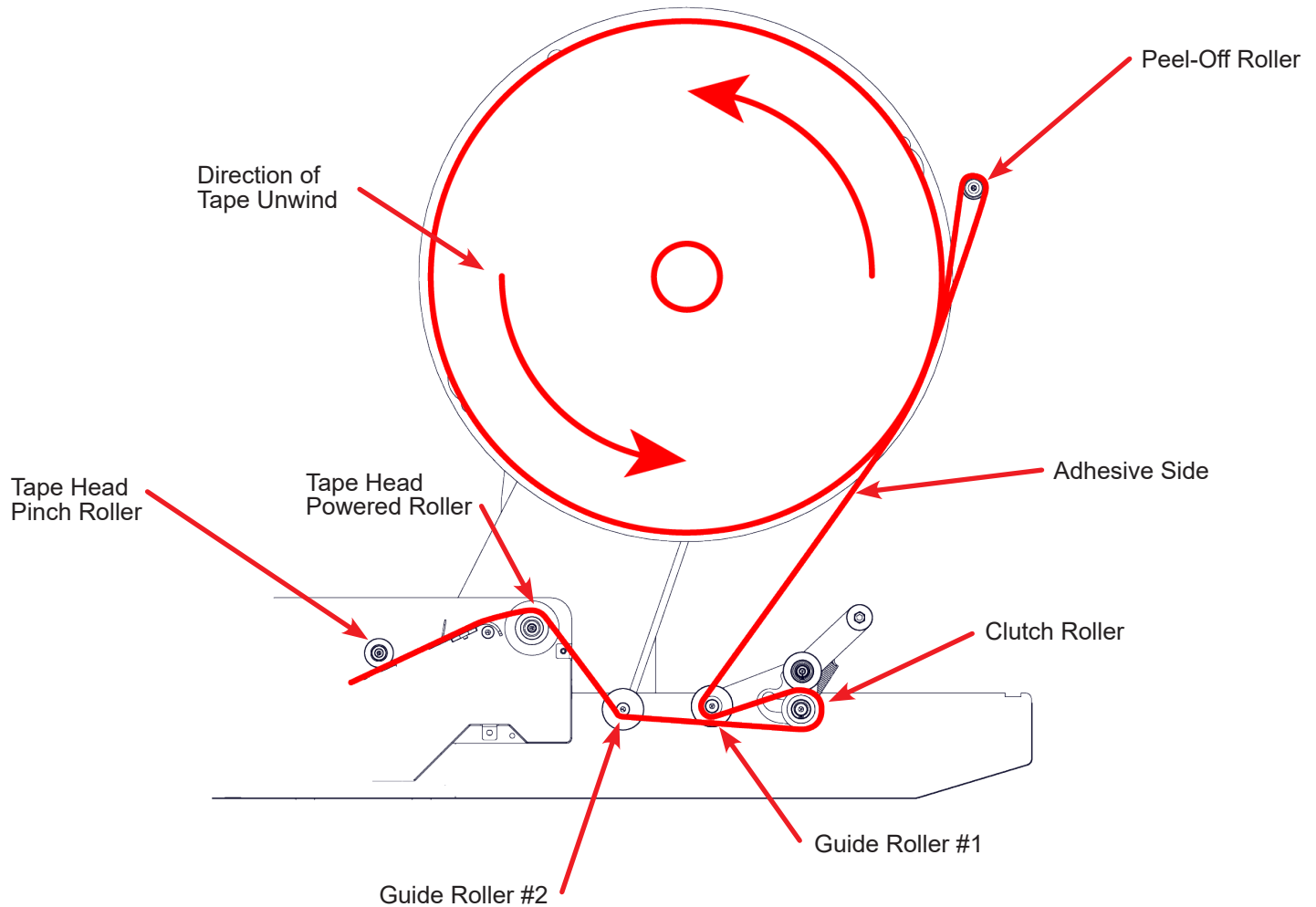

**Figure 39: Top Tape Path**

# TOP TAPE HEAD LOADING/THREADING

## Top Tape Loading/Threading Instructions

The instructions below will assist in threading tape on the top tape head.

1. Put machine in Manual Mode using Manual/Auto selector switch (Item 1).
2. Install tape roll on to mandrel making sure the unwind direction is counterclockwise.
3. Pull tape around the top of the peel-off roller and towards the rear of the machine, under the tape roll (Item 5).
4. Bring tape under Guide Roller #1 (Item 6) followed by bringing the tape through the clutch roller (Item 7).
5. Pass the tape under Guide Rollers #1 and #2 (Item 8) before pulling the tape upward into the tape head.
6. Bring the tape over the powered drive roller (Item 9) and towards pinch roller (Item 10).
7. Thread tape under guide plate until it reaches the pinch roller. During this process, make sure pinch roller is not engaged. To engage/disengage the pinch roller, use the Tape Threading/Stop button (Item 2) located on the control box.
8. Once tape has been passed under the pinch roller, engage pinch roller using Tape Threading/Stop button (Item 2).
9. Press down the Tape Feed button (Item 3) to allow machine to pass tape through tape shoe and feed out of the tape head.
10. If tape passes with no jams, remove tape from tape shoe guide, and press Start button (Item 4) and hold for one second to begin machine operation. If you encounter a jam, see Clear Mode (Clear Jam), on [page 36](#).

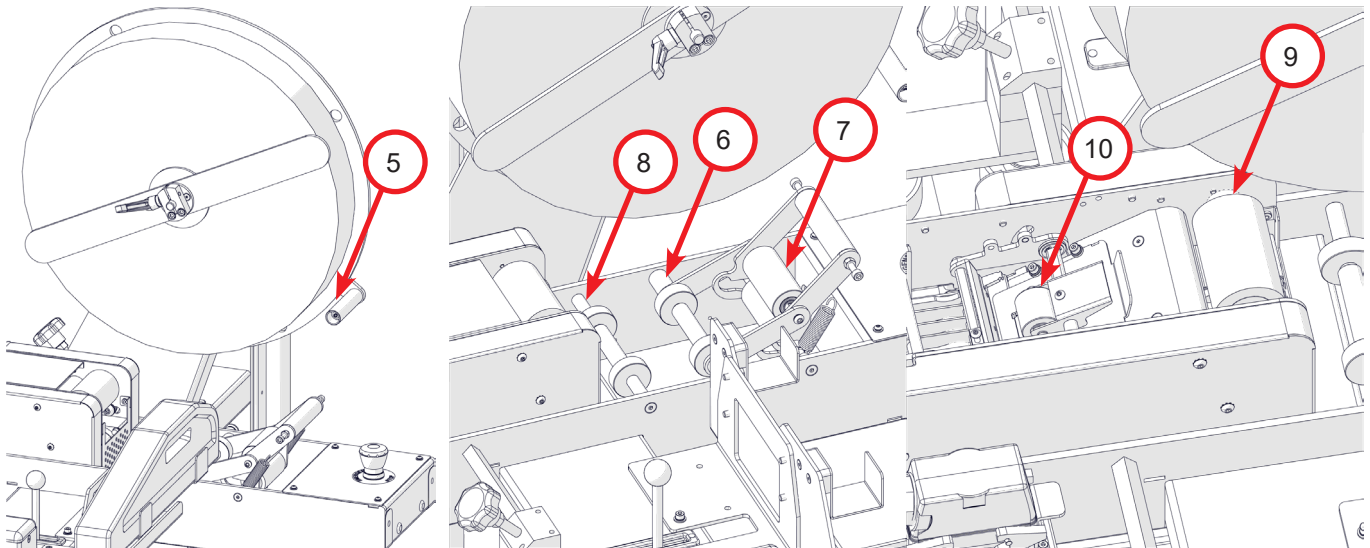
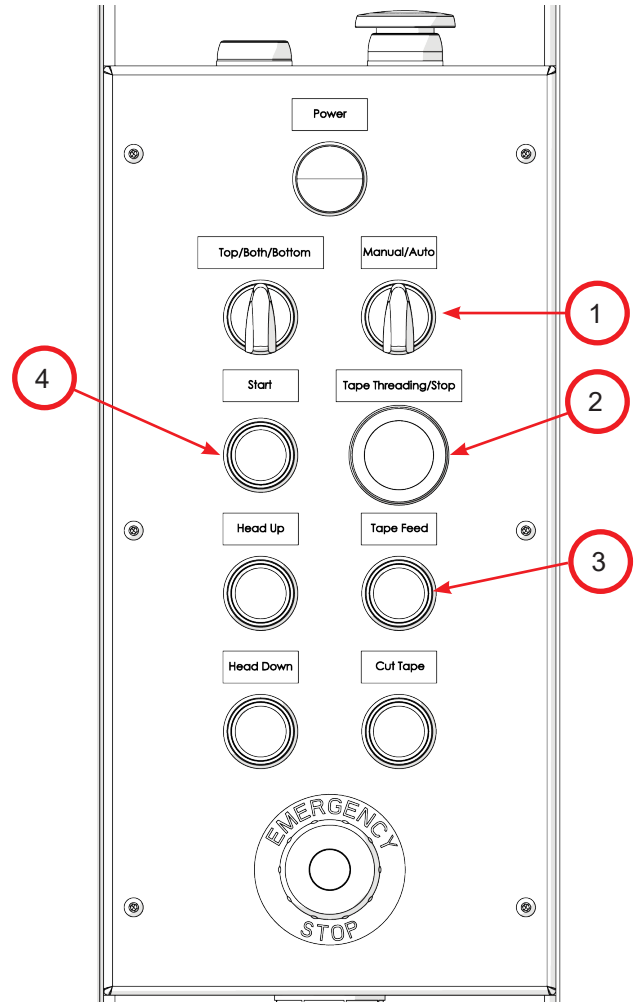
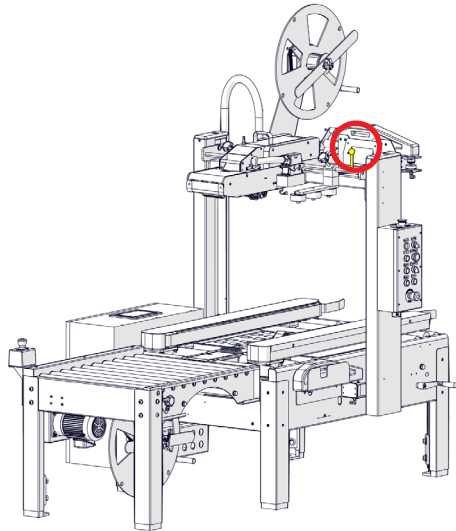

Figure 40: Top Tape Loading Procedure

# REMOVING/REPLACING THE TOP TAPE HEAD

The tape head is 36lbs (16kg). Use proper lifting techniques to reduce the risk of strain. Press the Emergency-Stop before removing the tape head.

1. To remove the top tape head start by lowering the bridge to the lowest it will go.
2. Unlock the bridge using the locking handle.



**Figure 41: Top Tape Head Removal 1**

3. Lower the bridge to the lowest position it can go, then lock the handle.

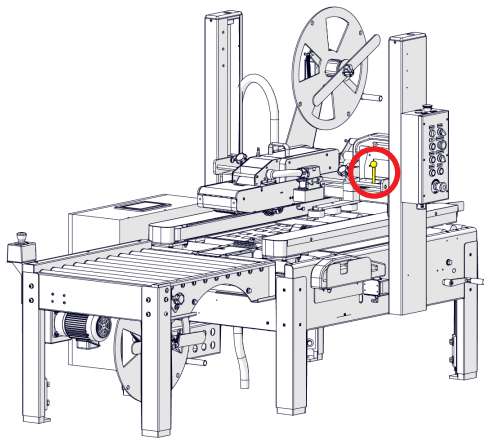

**Figure 42: Top Tape Head Removal 2**

4. Disconnect the tape head from energy sources.
5. Close the water valve before disconnecting the water line.

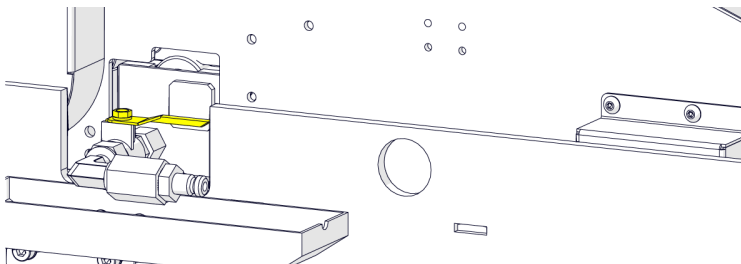

**Figure 43: Top Tape Head Removal 3**

6. Disconnect the pneumatic connector.
7. Unlock the power connector before lifting it straight up.

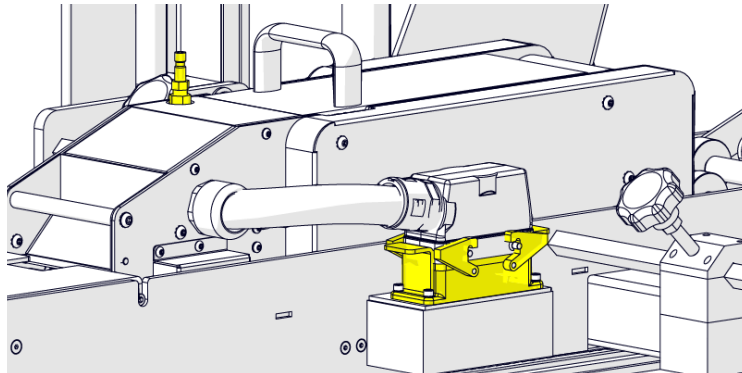

**Figure 44: Top Tape Head Removal 4**

8. Lift the tape head locking plate. You may need to push the tape head toward the front of the machine to release the locking plate.

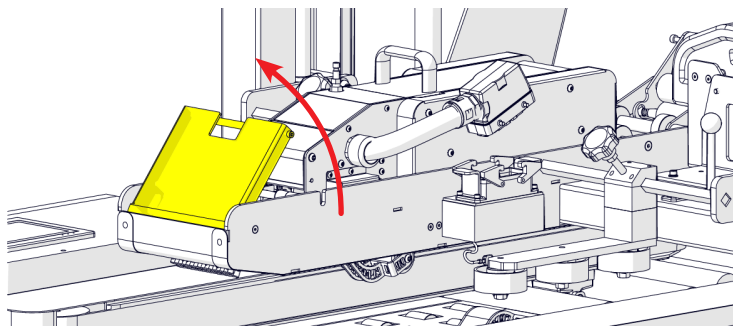

**Figure 45: Top Tape Head Removal 5**

9. The tape head can be lifted out of the bridge.

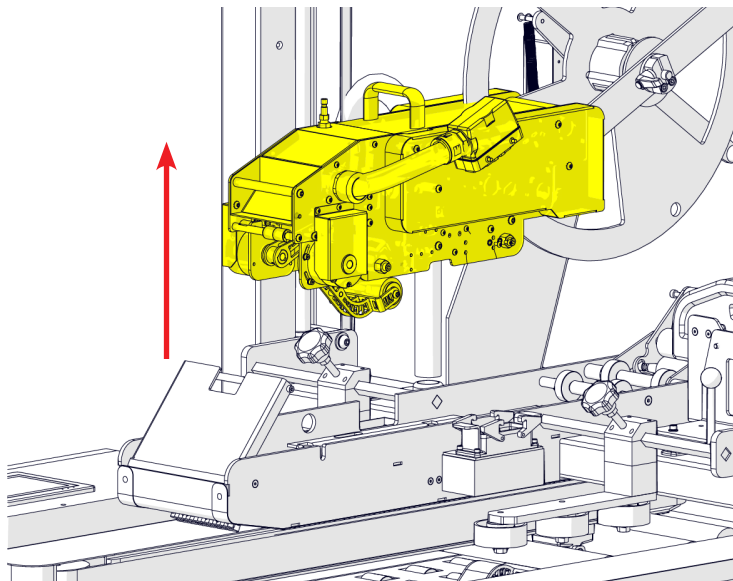
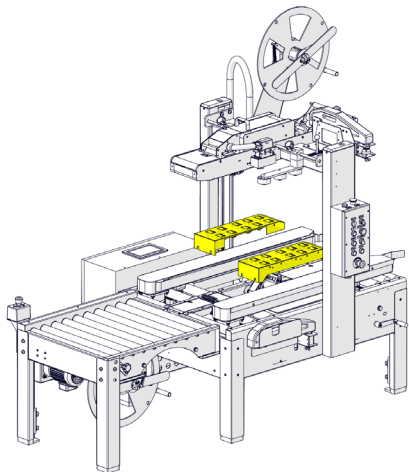

**Figure 46: Top Tape Head Removal 6**

# REMOVING/REPLACING THE BOTTOM TAPE HEAD

The tape head is 36lbs (16kg). Use proper lifting techniques to reduce the risk of strain. Press the Emergency-Stop before removing the tape head.

1. Bottom Tape Heads are held in place by gravity. If not already, use the crank handle to open the belts.
2. If the bridge is not raised unlock the bridge using the locking handle.
3. Raise the bridge to its maximum allowed position. Then lock the bridge.
4. Remove the two (2) roller fill plates on either side of the bottom tape head.



**Figure 47: Bottom Tape Head Removal 1**

5. Disconnect the tape head from all energy sources.
6. Unlock the large electrical connector and pull it straight out.

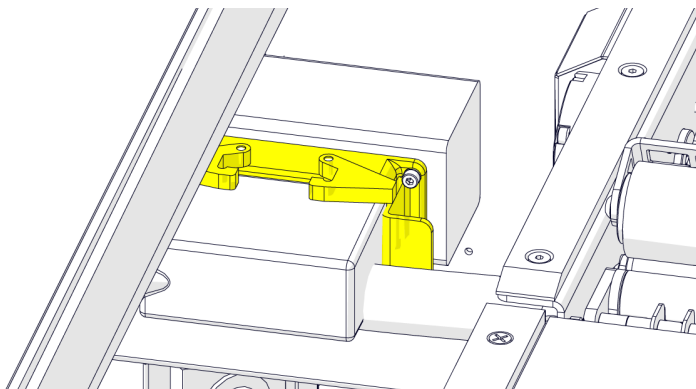

**Figure 48: Bottom Tape Head Removal 2**

7. Disconnect the air supply to the bottom tape head.

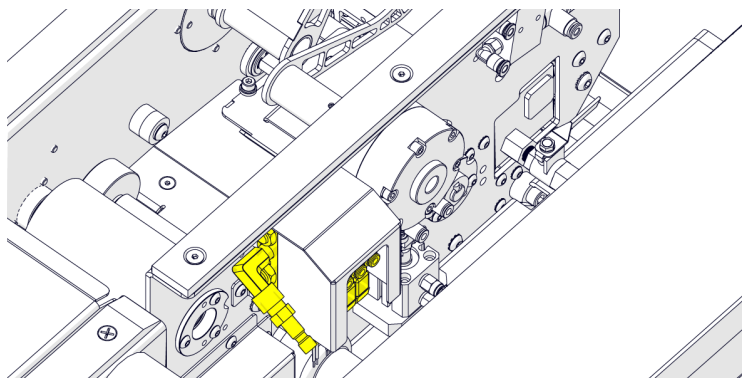

**Figure 49: Bottom Tape Head Removal 3**

8. Close the valve on water pot and disconnect the water supply.

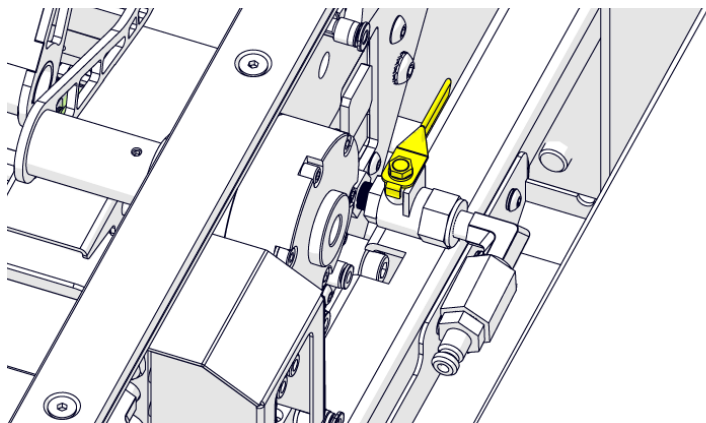

**Figure 50: Bottom Tape Head Removal 4**

9. Pull the tape head straight out of the cavity.

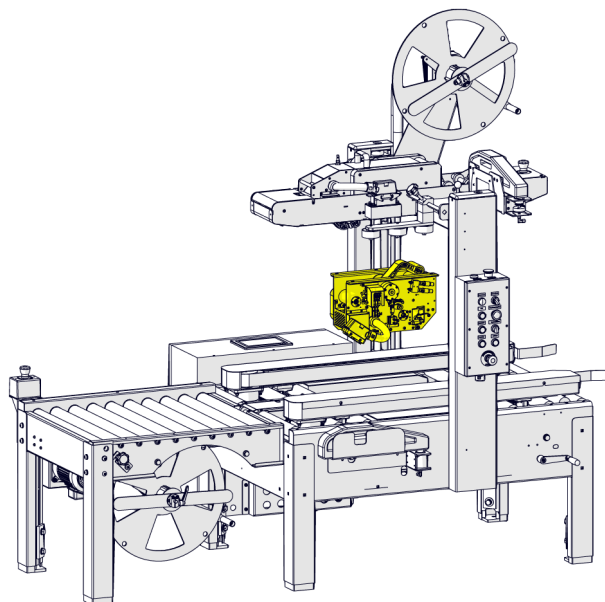
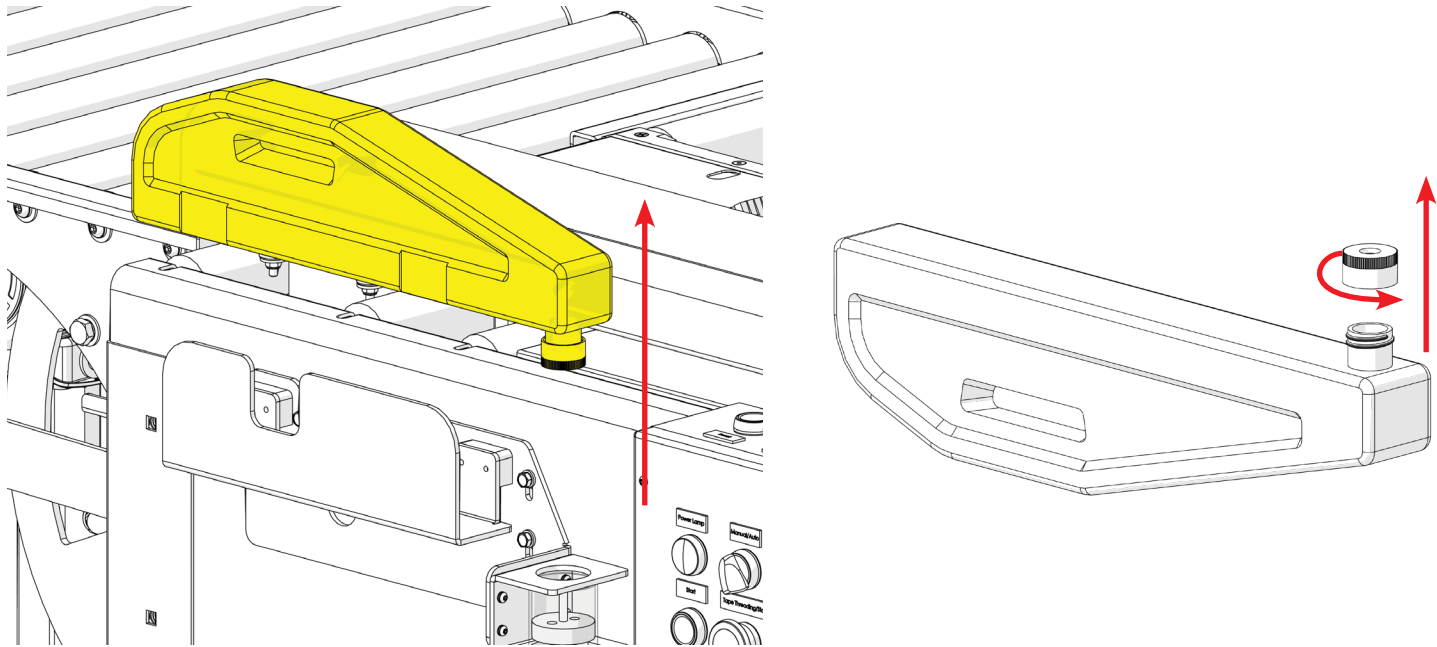

**Figure 51: Bottom Tape Head Removal 5**

# ADDING WATER TO THE SYSTEM

The **USA 2024-WAT** comes equipped with two 64oz water bottles to supply the tape heads with water.

1. Remove the water bottle by pulling them straight up from support bracket.
2. Turn the bottles over so the water will not spill.
3. Unscrew the water bottle cap.
4. Fill the bottle with warm water, distilled or filtered water is preferred when tap water contains excess minerals.
5. Replace the water cap.
6. Install the water bottle by inserting it over the water cup post and into the support bracket on the side of the machine.



**Figure 52: Adding Water to the System**

# ADJUSTING THE WATER LEVEL

Depending on volume of cartons that are being processed through the USA 2024-WAT the water level may need to be adjusted. Water is transported into the water pot through a gravity fed line. The water level is controlled by raising and lowering the water bottle assemblies.

## Adjusting the top water level

1. Remove the top water bottle.
2. To adjust the water level on the top loosen the four (4) 10mm bolts on the water bottle retainer.

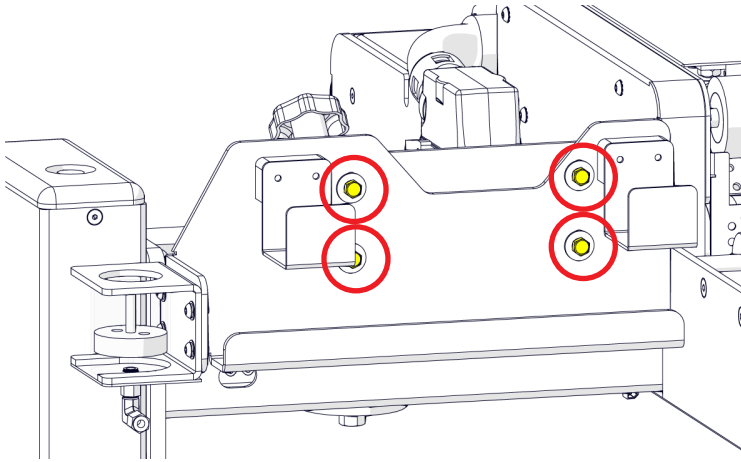

**Figure 53: Top Water Level Adjustment 1**

3. The water bottle retainer has slotted holes allowing for it to slide.
4. Shift the water bottle retainer up to raise the water level in the water pot.
  - If the water level is raised all the way up some splashing may occur and can cause water to drip into the lower part of the machine.
5. Shift the water bottle retainer down to lower the water level in the water pot.

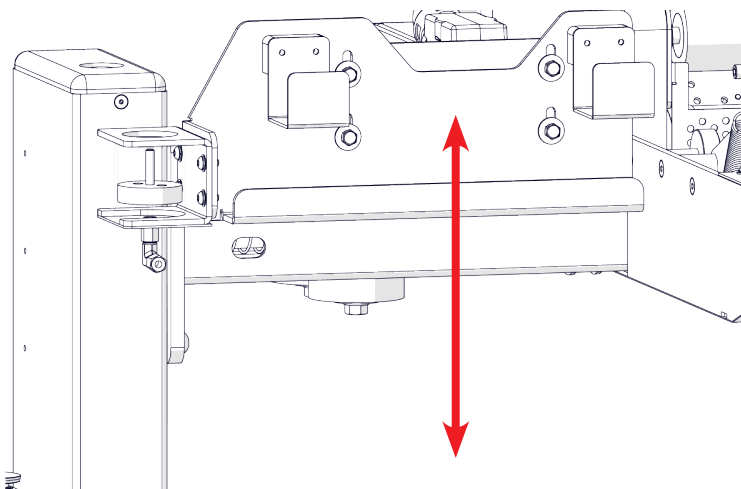

**Figure 54: Top Water Level Adjustment 2**

## Adjusting the bottom water level

1. Remove the top water bottle.
2. To adjust the water level on the bottom loosen the four (4) 10mm bolts on the water bottle retainer.

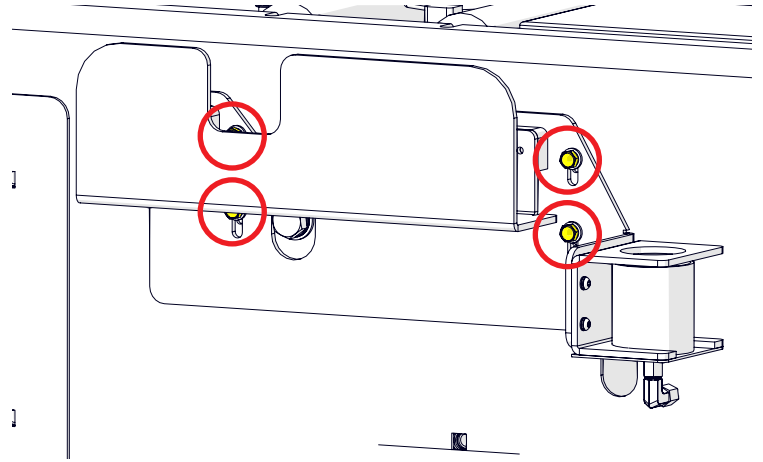

**Figure 55: Bottom Water Level Adjustment 1**

3. The water bottle retainer has slotted holes allowing for it to slide.
4. Shift the water bottle retainer up to raise the water level in the water pot.
  - If the water level is raised all the way up some splashing may occur and can cause water to drip onto the floor under the machine.
5. Shift the water bottle retainer down to lower the water level in the water pot.

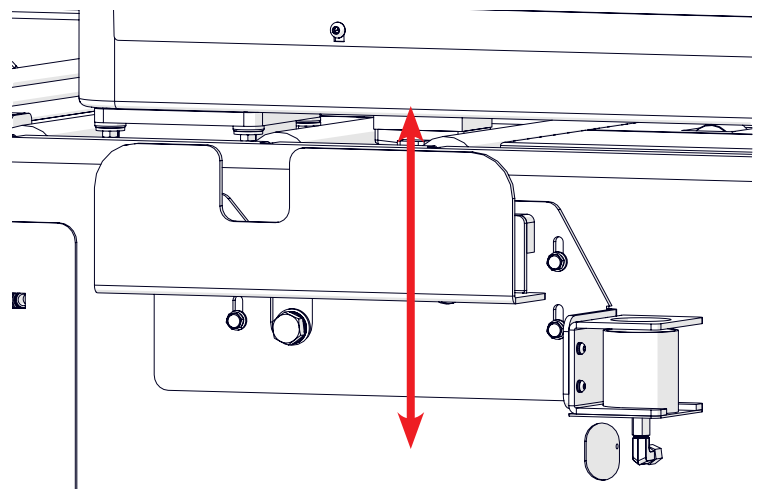
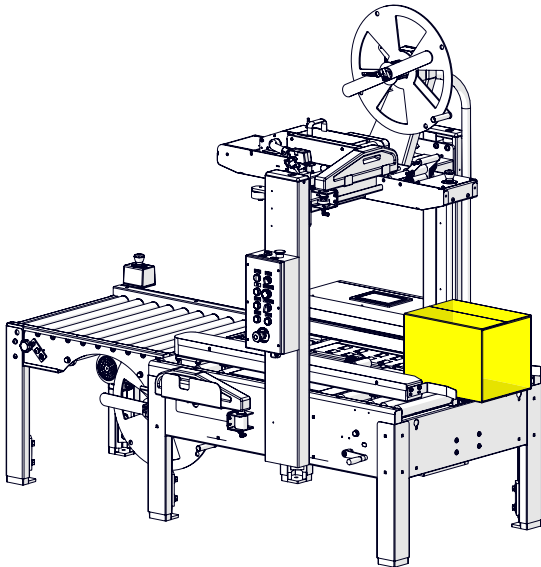

**Figure 56: Bottom Water Level Adjustment 2**

# CASE SETUP PROCEDURE

Setting up the **USA 2024-WAT** to process a case size is quick and easy. When performing any setup procedure press the Emergency Stop to prevent any unintended action or motion.

1. Press the Emergency Stop to prevent any unintended action or motion.
2. Fold all of the flaps on the carton and place it between the belts at the front of the machine.
  - If the carton does not immediately fit you may need to use the crank handle to open the belts.
  - If the carton does not immediately fit under the bridge you may need to unlock the bridge using the locking handle and raise the bridge all the way.



**Figure 57: Place Carton in Machine**

3. Use the crank handle to bring the belts in. They should be pressed against the carton firmly so it cannot easily be pulled out by hand. Do not over tighten the belts.

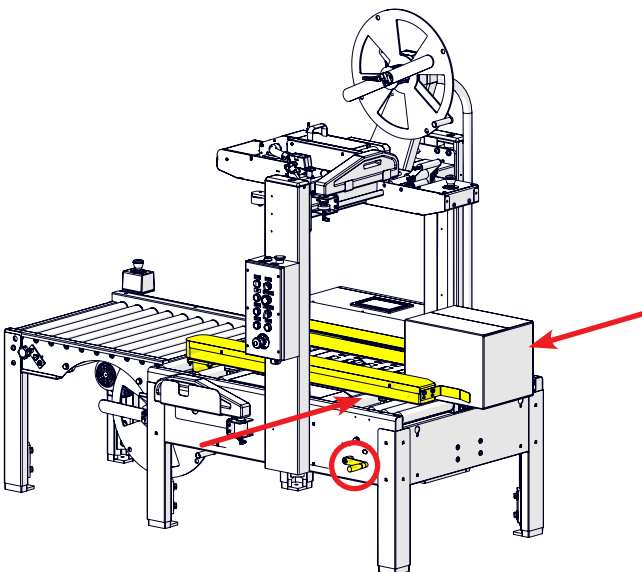

**Figure 58: Tightening the Belts**

4. Unlock the bridge using the locking handle and lower the bridge until it rests on the top of the carton. Do not press the bridge into the carton it only needs to apply a light downward pressure onto the carton. Lock the bridge in place.

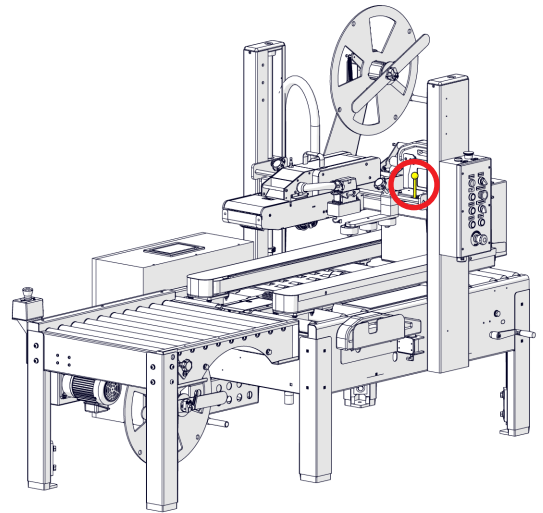

**Figure 59: Position the Bridge**

5. Disengage the Emergency Stop, press the Reset Button, flip the Manual/Auto Switch to Manual and press and hold the Belt Drive button until the case is next to the top squeezers.
  - You may need to open the top squeezers to allow the new carton size through. Not doing this may result in a jam.

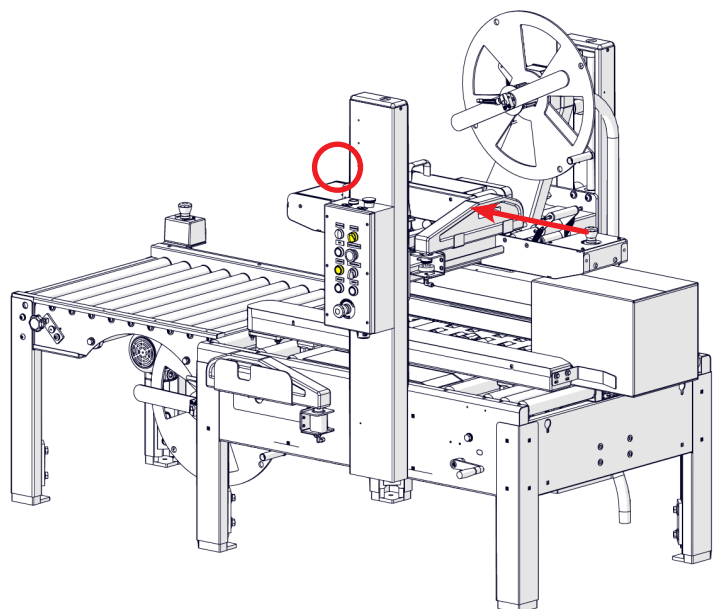

**Figure 60: Advance the Carton**

# CASE SETUP PROCEDURE CONTINUED

6. Loosen the grips on the top squeezers. Slide them into carton so the wheels make contact lightly with the carton. Do not over tighten the squeezers to the carton as it can result in case jams.

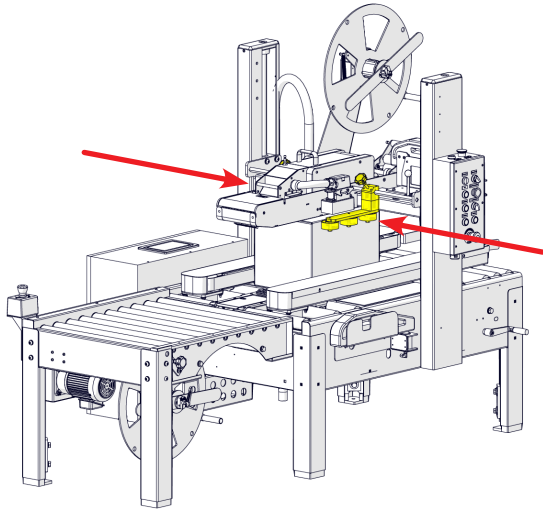

**Figure 61: Setting the Top Squeezers**

7. Press and hold the Belt Drive Button until the carton has exited the belts.

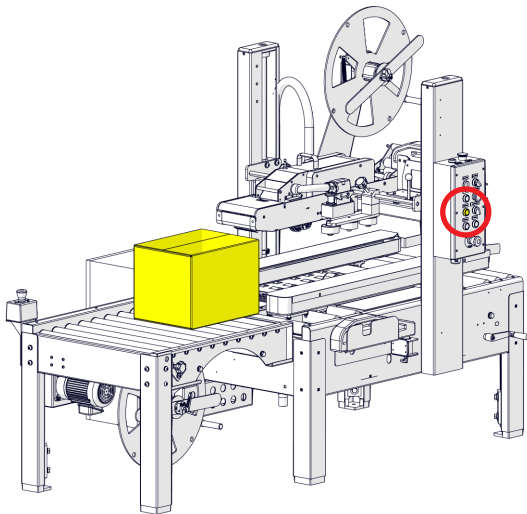

**Figure 62: Removing Carton from Machine**

8. Remove the carton. Flip the Manual/Auto Switch to Auto.
9. To begin normal operation press the Green Start Button.

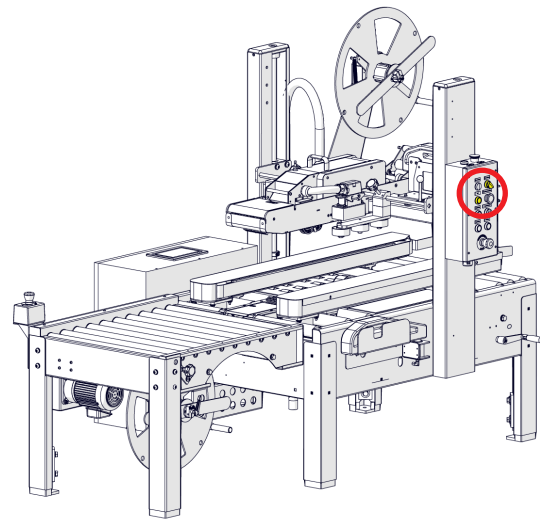

**Figure 63: Start Normal Operations**

10. Present a new carton to the machine to be processed normally.



# OPERATING INSTRUCTIONS

---

The following instructions are presented in the order recommended for processing cases through the **USA 2024-WAT** Case Sealer.

1. Install and thread tape on the tape head(s) (refer to the tape threading section).
2. Supply or connect the machine to 110V Electrical Supply (refer to Electrical Utilities).
3. Supply or connect the machine to Pneumatic Supply (refer to Pneumatic Utilities).
4. Follow the Case Set-up Procedure if the case sealer is not already set up.
5. Verify that all Emergency-Stops are disengaged.
6. If not done so press the Reset Button (if engaged the Reset Button will be illuminated solid, otherwise it will be blinking).
7. Verify the machine is in Auto Mode.
8. Press the Green Start button to begin machine operation.
9. The operator will need to manually fold all the carton's flaps.
10. The operator should present the carton to the belts holding the top rear of the carton.
11. The carton should be square when entering the machine.
12. The operator should allow the machine to take the carton. It is not necessary for the operators hands to be near the moving components.
13. The pneumatic gate will raise preventing the next carton from entering until the machine is ready.



**WARNING: ENSURE THAT THE OPERATOR'S HANDS ARE AWAY FROM THE CONTACT AREA BETWEEN THE BOTTOM OF THE CARTON AND THE MOVING BELTS. OPERATORS SHOULD GRIP THE CASE AT THE REAR AND LET GO ONCE THE MACHINE HAS TAKEN THE CASE. IMPROPER HANDLING CAN LEAD TO INJURY.**



**WARNING: KEEP HANDS, HAIR, LOOSE CLOTHING, AND JEWELRY AWAY FROM MOVING BELTS, AND TAPE HEADS**



**WARNING: KEEP HANDS AND OTHER BODY PARTS CLEAR OF THE BOTTOM OF THE MACHINE BRIDGE. THIS MAY POSE A MINOR CRUSH HAZARD.**

When feeding cartons into the Case Sealer bottom minor flaps must be closed prior to entering the belts. Be sure that all cases are fed squarely and straightly into the Case Sealer, feeding cases crooked can result in poor seals or case jams.

In the event of a case jam follow the below procedure. Do not attempt to clear a jam while the case sealer is on. Press the Emergency Stop button before proceeding.



**WARNING: DO NOT ATTEMPT TO REMOVE ANY JAMMED CASE FROM A CASE SEALER THAT IS CURRENTLY ON. DO NOT ATTEMPT TO PUSH A JAMMED CASE THROUGH THE MACHINE. THE MACHINE HAS COMPONENTS UNDER PNEUMATIC PRESSURE. NOT FOLLOWING THE PROPER CASE JAM CLEARING METHODS CAN RESULT IN INJURY.**

## Carton Jam Clearing

1. Press the Emergency Stop. This will cause the pneumatic pressure to vent from the machine.
2. Unlock the bridge and raise it.
3. Using the crank handle slightly open the belts.
4. The carton can be removed by hand.
5. If tape is attached to the carton use scissors to cut the tape free.
6. Inspect the tape head(s) for any damage or mis-threaded tape.
7. Disengage the Emergency Stop and press the Reset Button.
8. Flip the Manual/Auto Switch to Manual
9. Press the Tape Feed Button to prime the tape heads.
10. Follow the Carton Set-up Procedure to reset the machine.

# OPERATING INSTRUCTIONS

## HMI Windows and Explanations

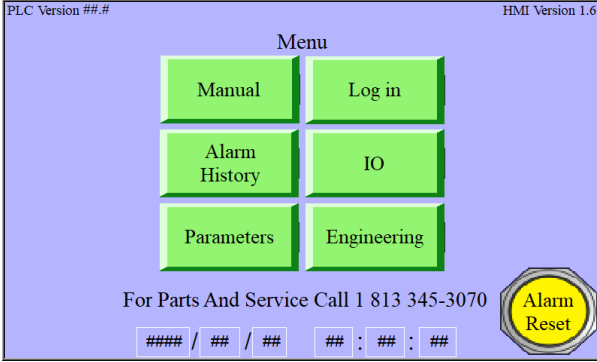

This is the Home screen of the HMI that is available to all users of the machine. If an error is not easily identifiable it will display on this screen. If the error has been cleared and no longer displays on the Home screen the operator can press Alarm History to view the various alarms that have come up on the machine.

The Parameters and Engineering options are locked behind passwords. These sections will allow for operators to change machine settings.

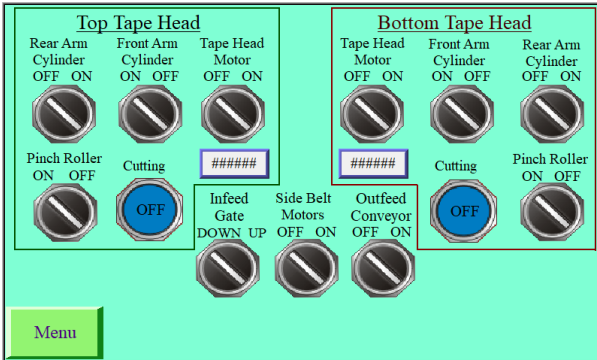

### Manual Screen

This screen will allow operators to have manual control over the various actuating elements of the USA WAT machine. Manual actuation can only be conducted when the switch on the operator control box is set to manual. In the bottom only version of the machine the HMI program is the same as the standard machine and will still show elements of the Top Tape Head.

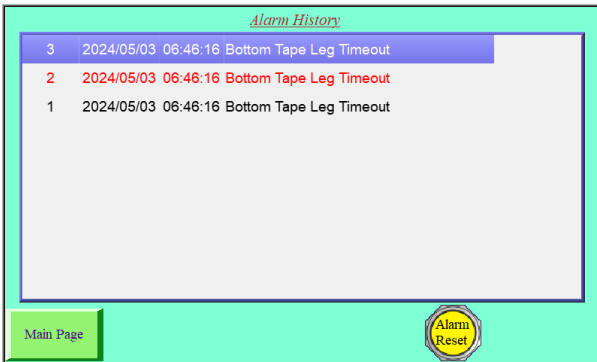

### Alarm History Screen

This screen will allow operators to view how many alarms and when (date and time) they occurred. This screen is helpful when performing troubleshooting as repeated alarms in close time proximity may help narrow down any adjustments that will be needed.

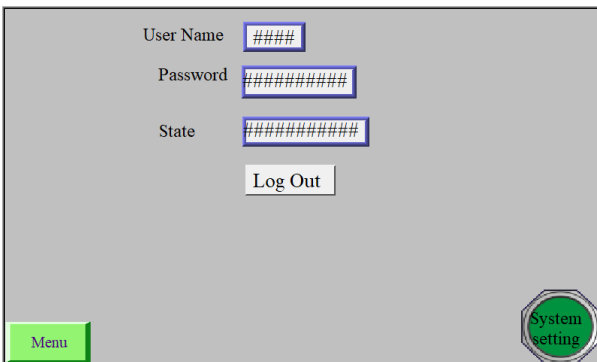

### Log In Screen

This screen will allow operators and service personnel to log in and gain access to adjust machine settings.

# OPERATING INSTRUCTIONS

## HMI Windows and Explanations

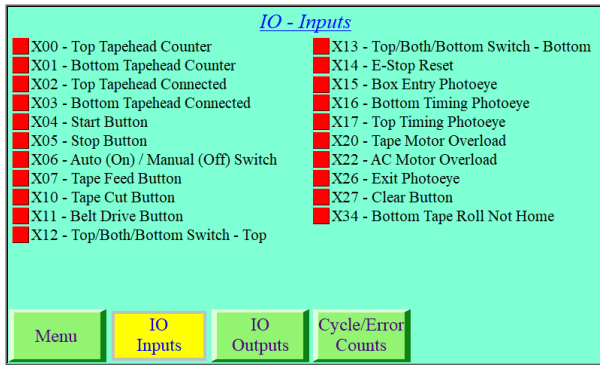

### I/O Screens

This screen will allow operators to view all PLC inputs and outputs along with their state. These screens will help operators in the performance of troubleshooting.

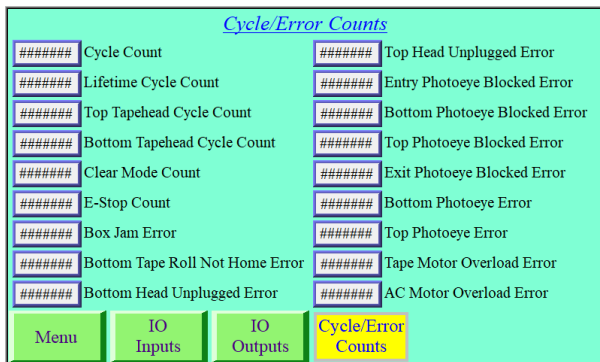

### Cycle Count Screen

This screen will allow operators to view machine cycle counts. It is located in the I/O screen sub-menu. This screen will assist in performing preventative maintenance at regular intervals.

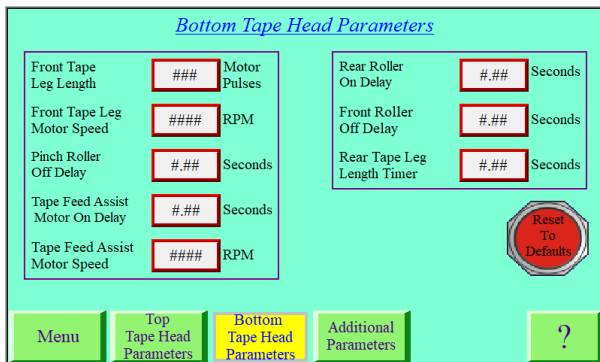

### Tape Head Parameter Screen

This screen is locked behind a Level 1 login. This allows operators to make adjustments to timing and speeds in relation to the tape head(s). Only qualified personnel should have the login information and make changes. Altering these settings can result in poor machine performance.

This screen also allows to restore settings to their default parameters.

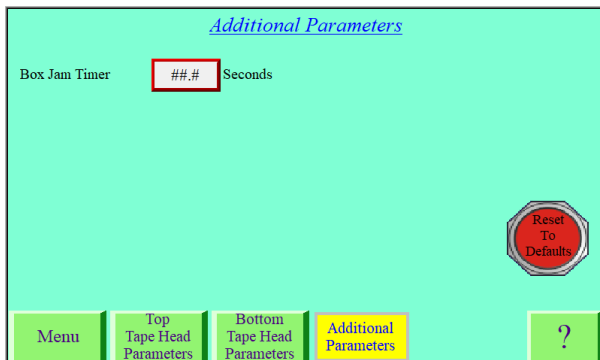

### Additional Parameter Screen

This screen is locked behind a Level 1 login. This allows operators to make adjustments to timing for box jams. Only qualified personnel should have the login information and make changes. Altering these settings can result in poor machine performance.

This screen also allows to restore settings to their default parameters.

# OPERATING INSTRUCTIONS

## HMI Windows and Explanations

<u>Help - Top Tapehead</u>	
Front Tape Leg Length	The length of tape on the front of the box based on the number of pulses output from the tapehead motor.
Front Tape Leg Motor Speed	Speed setting of the tapehead motor while the front tape leg is being dispensed. This is also the speed setting for manual mode.
Pinch Roller Off Delay	Time delay before the pinch roller releases the tape starting when the front tape leg is finished dispensing.
Tape Feed Assist Motor On Delay	Time delay before the tapehead motor turns on to assist feeding tape. Timer starts after the front edge of the box trips the top timing photoeye.
Tape Feed Assist Motor Speed	Speed setting of the tapehead motor while it is turning to assist tape feeding.
Rear Roller On Delay	Time delay before the rear wipedown roller is pressed against the box. Timing starts after the front edge of the box trips the top timing photoeye.
Front Roller Off Delay	Time delay before the front wipedown roller retracts from the box. Timing starts after the rear edge of the box passes the top timing photoeye.
Rear Tape Leg Length Timer	Timer that sets the length of the tape on the rear of the box. Tape is cut when the timer is done. Timing starts when the rear edge of the box passes the top timing photoeye.

### Help Screens

These screens can be accessed by selecting the “?” on any of the parameter adjustment screens. These screens will explain the relations that each of the parameters have to the operation of the machine.

Engineering Home

Bottom Tape Cut Timer/ Pinch Roller On Delay	###.##	Seconds	Top Tape Cut Timer/ Pinch Roller On Delay	###.##	Seconds
Bottom Rear Roller Home Delay	###.##	Seconds	Top Rear Roller Home Delay	###.##	Seconds
Bottom Front Roller Home Delay	###.##	Seconds	Top Front Roller Home Delay	###.##	Seconds

Reset Cycle Count

Reset Top Tapehead Cycle Count

Reset Bottom Tapehead Cycle Count

Reset Error Counts

Bottom Rear Trigger  
Front Rear

Top Rear Trigger  
Front Rear



Menu
Engineering Home
Top Tape Head Defaults
Bottom Tape Head Defaults
Additional Defaults
Set Date/Time

### Engineering Screens

These screens are locked behind the Level 2 login and should only be accessed by IPG authorized personnel. These screens will set what the machine considers the default values. These may be adjusted on a per-install basis.

These screens will also allow IPG authorized personnel to reset cycle counts, and set the date and time for the machine.

# PREPARING CASES TO BE PROCESSED CONTINUED

## Flap Folding

The **USA 2024-WAT** is a top and/or bottom sealer that will apply a single strip of IPG brand water activated tape to the center seams of a regular slotted carton (RSC). Cartons processed through the **USA 2024-WAT** will need to have all of the flaps closed for proper processing. If flaps are not closed there is a high likelihood that there will be a case jam or tape application error.

1. Fold minor flaps inward as shown in Figure 38
2. Fold major flaps inward, as shown in Figure 39

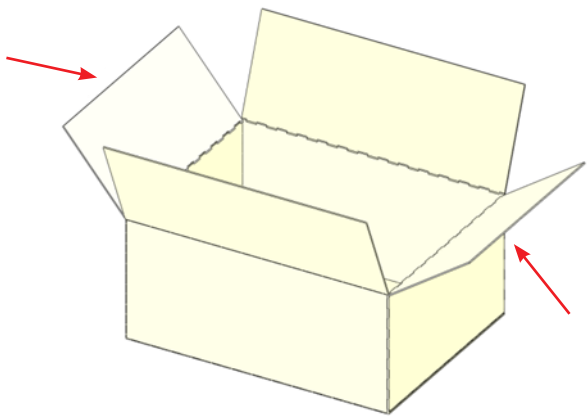

**Figure 64: Folding the Minor Flaps**

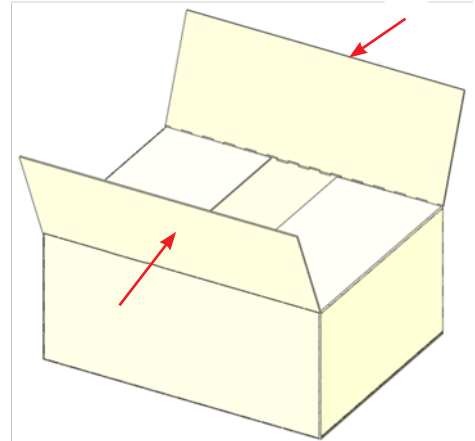

**Figure 65: Folding the Major Flaps**

## Over Filled and Void Filled Cartons

Care should be taken when processing over filled and void filled cartons. Both pose different challenges that may require some adjustments to the case sealer and/or tape heads.

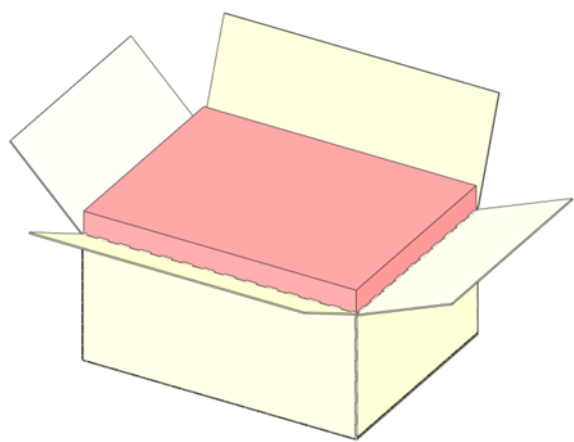

**Figure 66: Over Filled Carton**

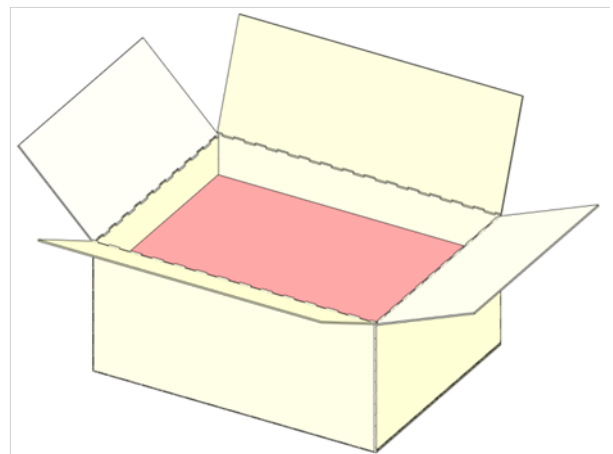
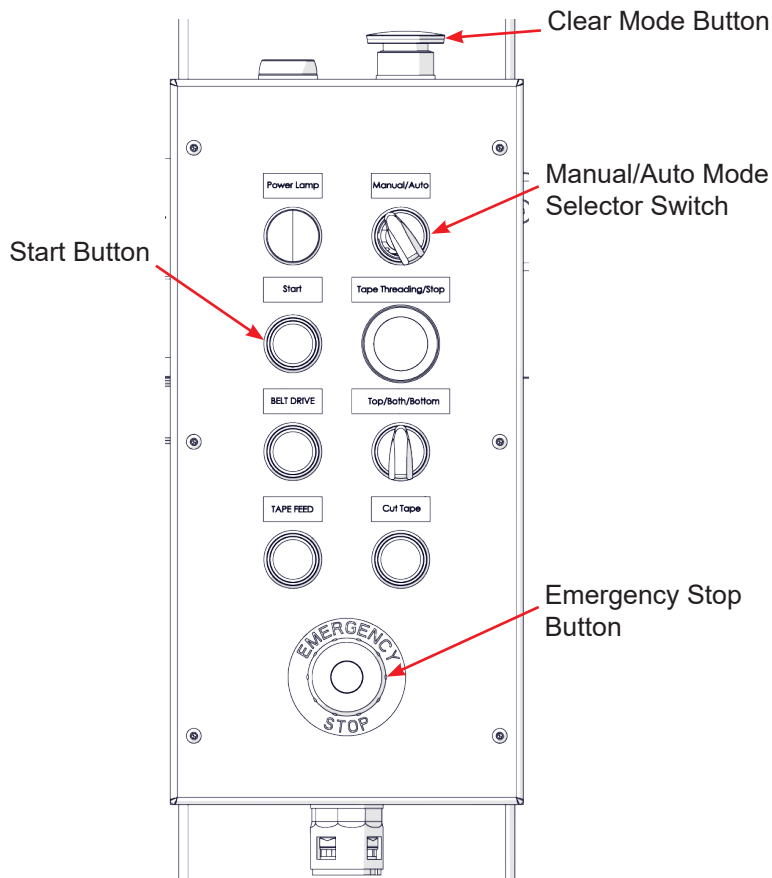

**Figure 67: Void Filled Carton**

# OPERATION MODES

## Control Box

The **USA 2024-WAT** Case Sealer has three operating modes. The operator selects these modes, using the 2-position switch and push button on the Control Box.



**Figure 68: Operator Controls**

## Auto Mode

This is the standard operating mode of the machine. In this mode, the belt motors and outfeed conveyor motor will be active. The belts will maintain their position unless an operator uses the hand crank to manually adjust their position. An operator will present a case, with all flaps closed, to the infeed of the case sealer. When the case is partially inserted into the belts the case sealer will grasp the case and process it, applying a single strip of IPG brand water activated tape to the top and/or bottom center seam.

1. Ensure that the compressed air is plugged and pressure regulator set to 75 PSI.
2. Turn the Manual/Auto selector switch on the control box to Auto (Automatic).
3. The case sealer is properly set up for the case size.
4. Press the Start button, the drive belts and outfeed table will turn on.
5. Introduce a case to the infeed of the case sealer. Grasping the case from the top or rear. Do not place hands in front of case.
6. The case will be processed and tape applied to the top and/or bottom center seam.
7. Once the case is processed the entry gate will drop allowing the operator to insert the next case.

## Manual Mode

This mode is used for troubleshooting and loading tape on to machine.

1. Ensure that the compressed air is plugged in and pressure regulator set at 75 PSI.
2. Turn the control selector to Manual mode.
3. Once set to Manual, buttons on control box can be used for troubleshooting or loading tape.
4. See Operator Control Box, for an explanation of button usage.

# TROUBLESHOOTING

The **USA 2024-WAT** Case Sealer comes equipped with a HMI screen that is located on the top of the electrical box. This screen offers users the ability to review a variety of alarm history details and to view the input and output IO for ease of troubleshooting assistance.

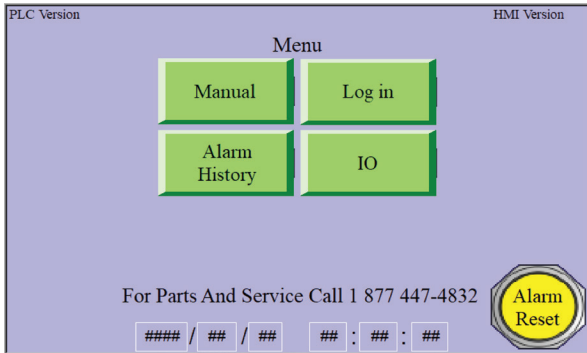

**Figure 69: HMI Home Screen**

This is the Home screen of the HMI that is available to all users of the machine. If an error is not easily identifiable it will display on this screen. If the error has been cleared and no longer displays on the Home screen the operator can press Alarm History to view the various alarms that have come up on the machine.



**Figure 70: HMI Alarm Screen**

This is the Alarm History screen of the HMI that is available to all users of the machine. This will display a full list of all alarms since install or the last date the alarms have been reset. In the event the error display on the Home screen has been reset it will have a history here.

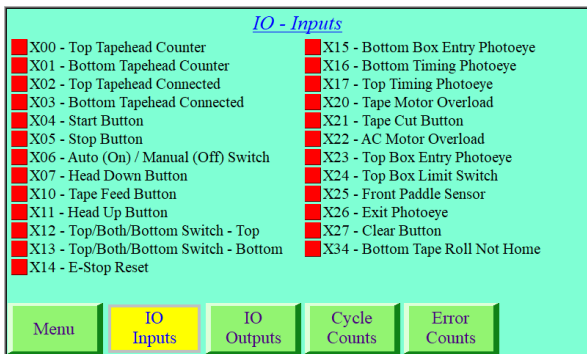

**Figure 71: HMI IO Input Screen**

This is the IO Input screen of the HMI that is available to all users of the machine. This displays a current, real-time, display of all the inputs and their states. When the blocks are red that means the PLC is not receiving signal from that source. When the blocks are green the PLC is receiving signal from that source. This is helpful when attempting troubleshooting.

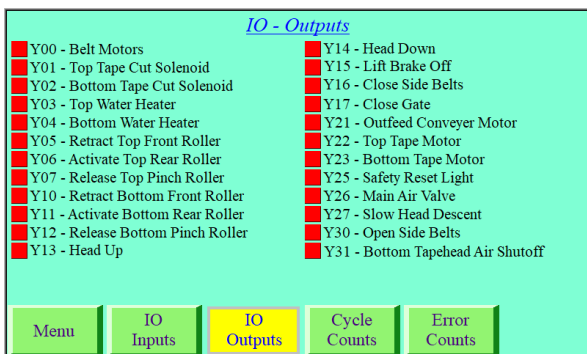

**Figure 72: HMI IO Output Screen**

This is the IO Output screen of the HMI that is available to all users of the machine. This displays a current, real-time, display of all the outputs and their states. When the blocks are red that means the PLC is not sending signal to that source. When the blocks are green the PLC is sending signal to that source. This is helpful when attempting troubleshooting.

# TROUBLESHOOTING

The USA 2024-WAT Case Sealer is fabricated with high quality components that provide trouble-free operation for a long period of time. However, should a problem occur, we recommend that you consult the following pages. If the problem you encounter is not discussed in these pages, call IPG Machinery Support at 813-345-3070.

## Motor Overload



**WARNING: MAKING ADJUSTMENTS TO MOTOR OVERLOADS OR ANYTHING IN THE ELECTRICAL CABINET SHOULD ONLY BE PERFORMED BY TECHNICIANS WHO HAVE BEEN APPROVED BY AN AUTHORIZED IPG REPRESENTATIVE. RISK OF ELECTRICAL SHOCK AND/OR EXPOSURE TO HIGH VOLTAGE COMPONENTS CAN OCCUR.**

In the event the Start button is pressed, and the machine is in automatic mode, the motors do not start it is recommended to check the motor overloads in the electrical cabinet.

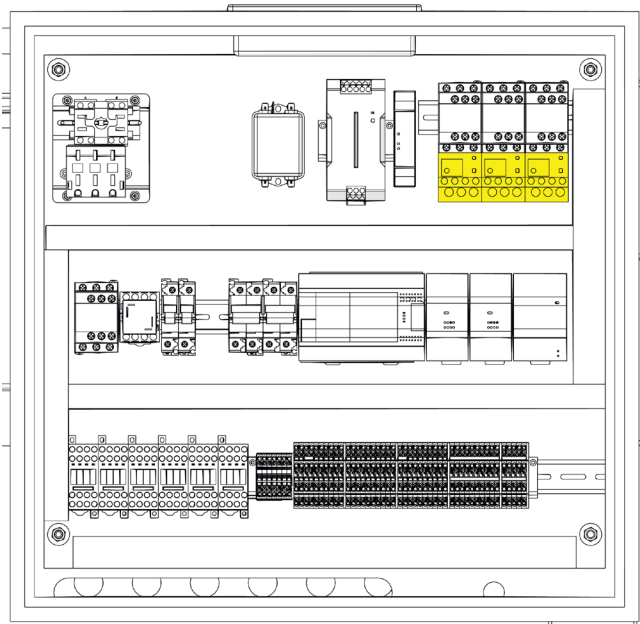

**Figure 73: Motor Overload Location**

The electric motors are protected with an automatic re-settable overload. Push on the top blue button to reset. The current setting should be set at 110% of the FLA (Full Load Amps) of a single motor.

In the event the motor continues to trip the overload the adjustable scale may be increased a small amount. On the Thermal Overload, protected by the hinged cover, is the adjustable dial.

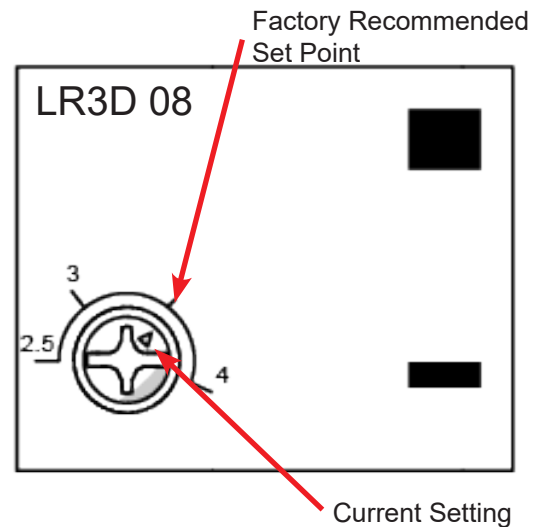
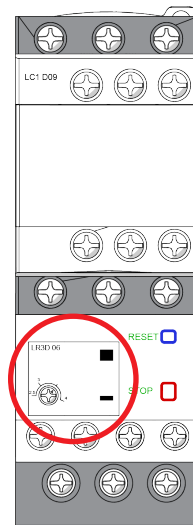

**Figure 74: Motor Overload Adjustment**

From the factory this dial should be set with the arrow pointing towards the shown point above.

In some cases this dial may be set too low resulting in false overloads. This will most likely be noticed when processing cases near the maximum weight limits of the case sealer.



# TROUBLESHOOTING

---

## Q & A

The following is a short set of brief questions and answers for some mild troubleshooting in WAT case sealers. More in-depth troubleshooting can be found in this section.

### **Q: How long is the tape good for once it gets wet?**

It is recommended to process a case within 45 seconds of the initial tape leg being dispensed. Any longer the adhesive will begin to dry and will not stick to the case. Case sealers running the newest software package will have a time out system that will automatically cut the tape and turn off the belts in the event this happens.

### **Q: Are the top and bottom tape heads interchangeable?**

IPG Water Activated Tape Heads are manufactured in a top or bottom configuration and are not interchangeable. A top Water Activated Tape Head from one IPG manufactured case sealer can be transferred to another in the top position and the same with the bottom.

IPG manufacturers a 24v version of the WAT heads for adaptation into other equipment. Do not attempt to install a 24v tape head into a machine that is not wired correctly for it.



**CAUTION: BE SURE TO NOT INSTALL 24V TAPE HEADS INTO EQUIPMENT THEY ARE NOT RATED FOR. THIS WILL CAUSE DAMAGE TO THE TAPE HEAD AND MAY RESULT IN INJURY.**

### **Q: Can pressure sensitive tape heads replace WAT ones?**

Due to manufacturing differences there is not a way to drop in replace the WAT heads with pressure sensitive counterparts.

### **Q: What is the best way to clean the tape heads?**

It is recommended to clean the tape path with a mild detergent and water solution. Do not use any harsh industrial cleaners as they can deteriorate parts quickly. Do not use excessive amounts of water and dry the tape head soon after washing. Be sure the tape path is dry before reinstalling the tape head or rethreading tape.

### **Q: Can we reverse the side the tape is loaded on?**

On WAT case sealers it is a special order to reverse the top tape mandrel to allow for it to be loaded from the reverse side. The bottom tape carriage cannot be reversed.

### **Q: Can I use a mobile compressor to operate the case sealer?**

It is recommended to use a large compressor capable of producing a sustained 9 CFM at 90 PSI. If a compressor is used that is below this level it is possible to have unintended action, poor taping, or even a lack of pneumatic movement entirely. Smaller compressors are also more likely to introduce moisture into the air lines which can cause a degradation of internal components on the case sealer and tape head(s). Use only clean dry air with IPG manufactured equipment.

### **Q: Can I change machine settings?**

While IPG WAT Case Sealers can have their settings adjusted through a password protected portion of the HMI screen it is recommended to contact IPG Machine Support prior to making any changes. The machine should have been set up by an Authorized IPG Representative and any tweaks that would need to have been made on site for your specific box suite would have been saved. Making changes to the settings could result in poor tape application, unintended movement, or potentially damage the equipment.

# TROUBLESHOOTING

## The Machine is Turned on and Nothing Happens

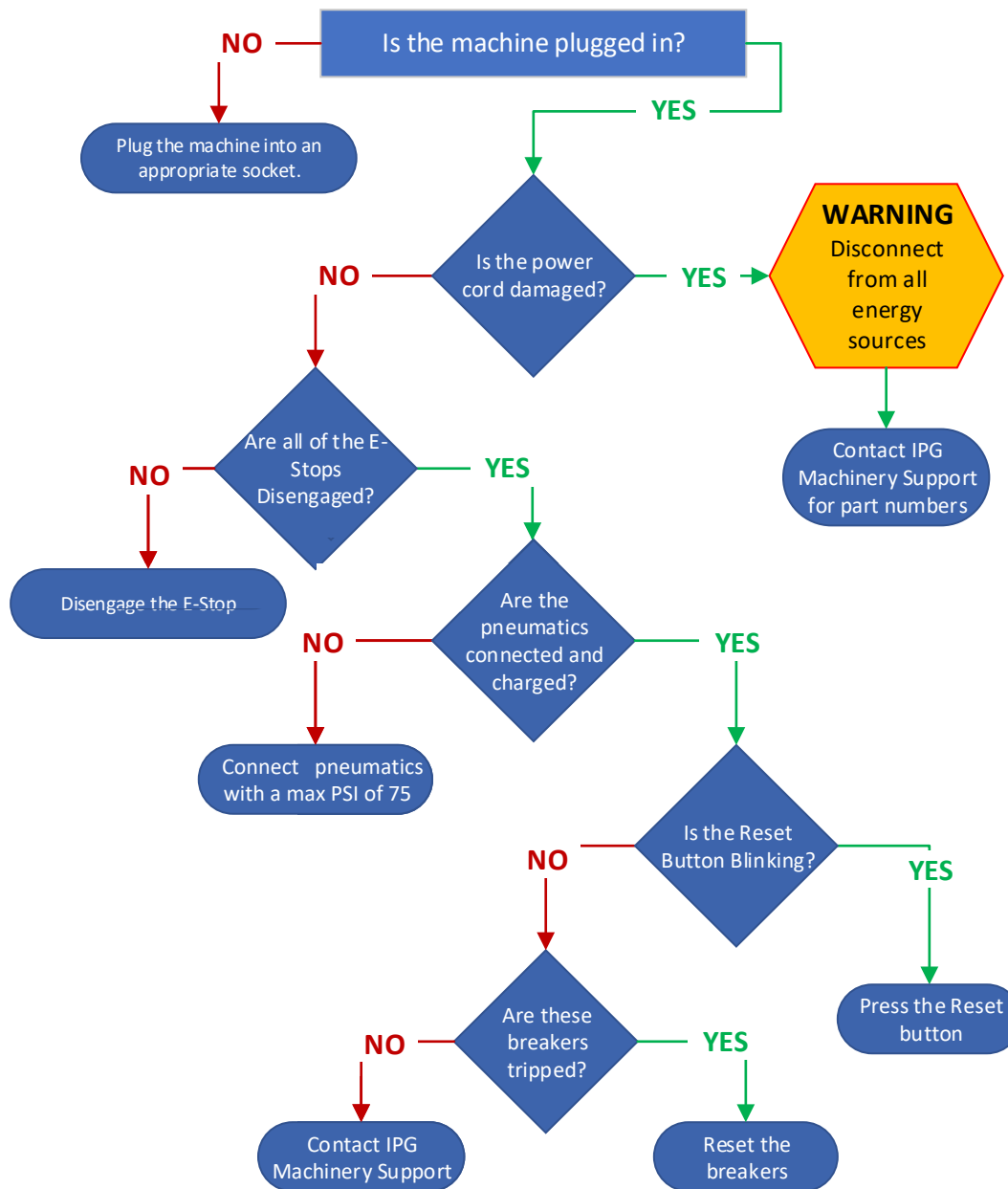

IPG Machinery Support  
877-447-4832 Option 4

## Front Tape Leg Not Sticking

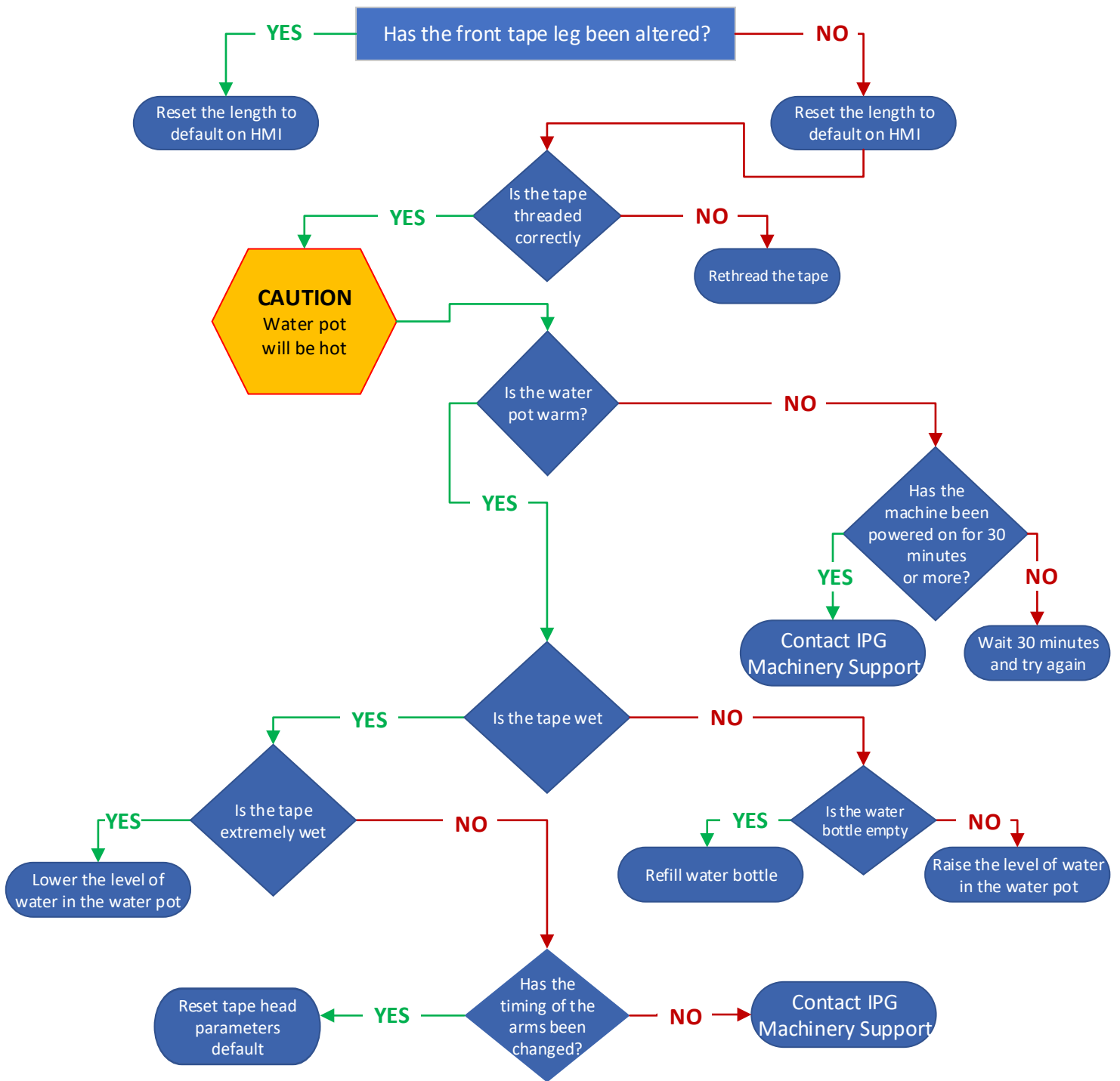

IPG Machinery Support  
877-447-4832 Option 4

## Rear Tape Leg Not Sticking

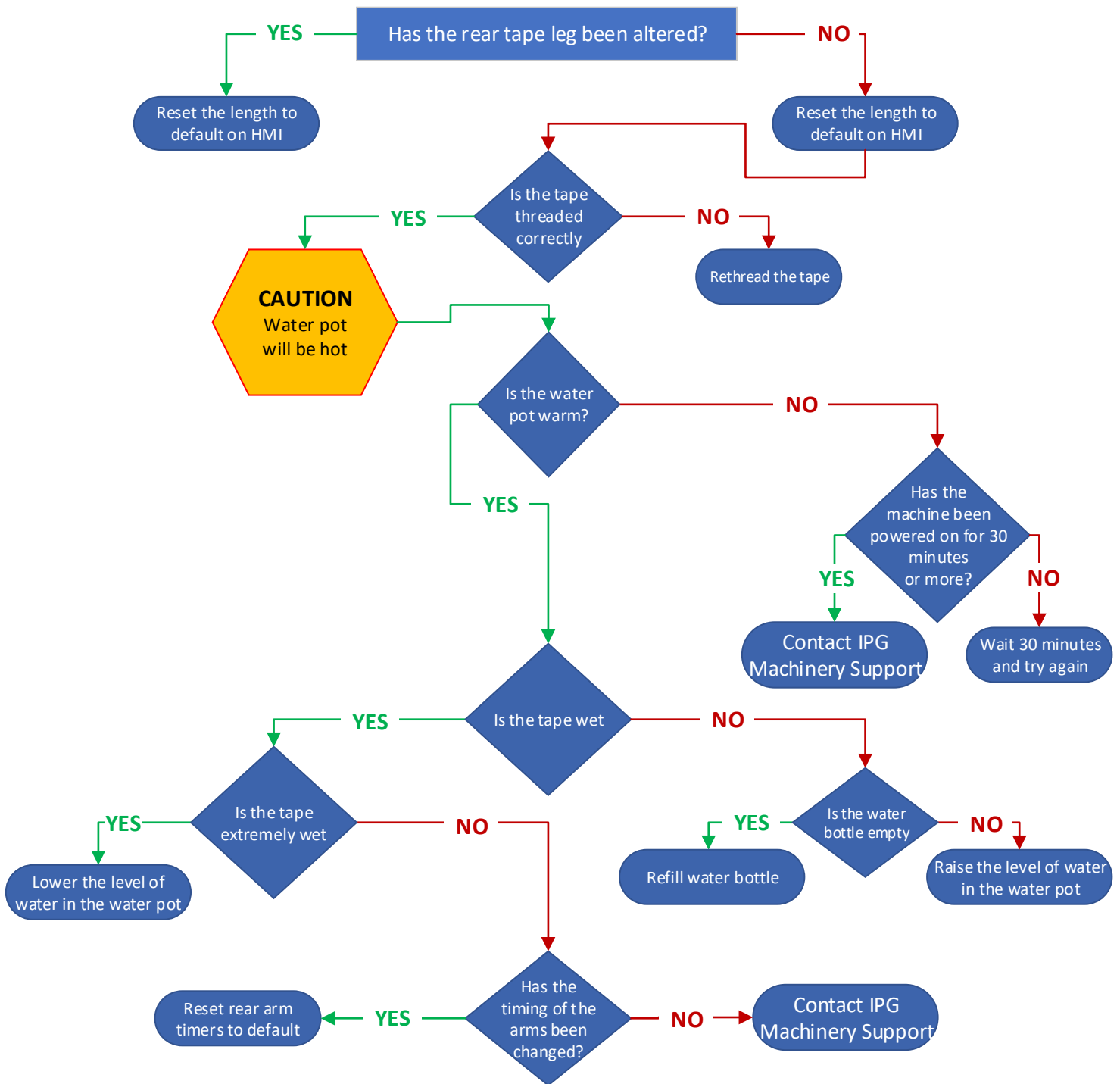

IPG Machinery Support  
877-447-4832 Option 4

## Tape Does Not Cut

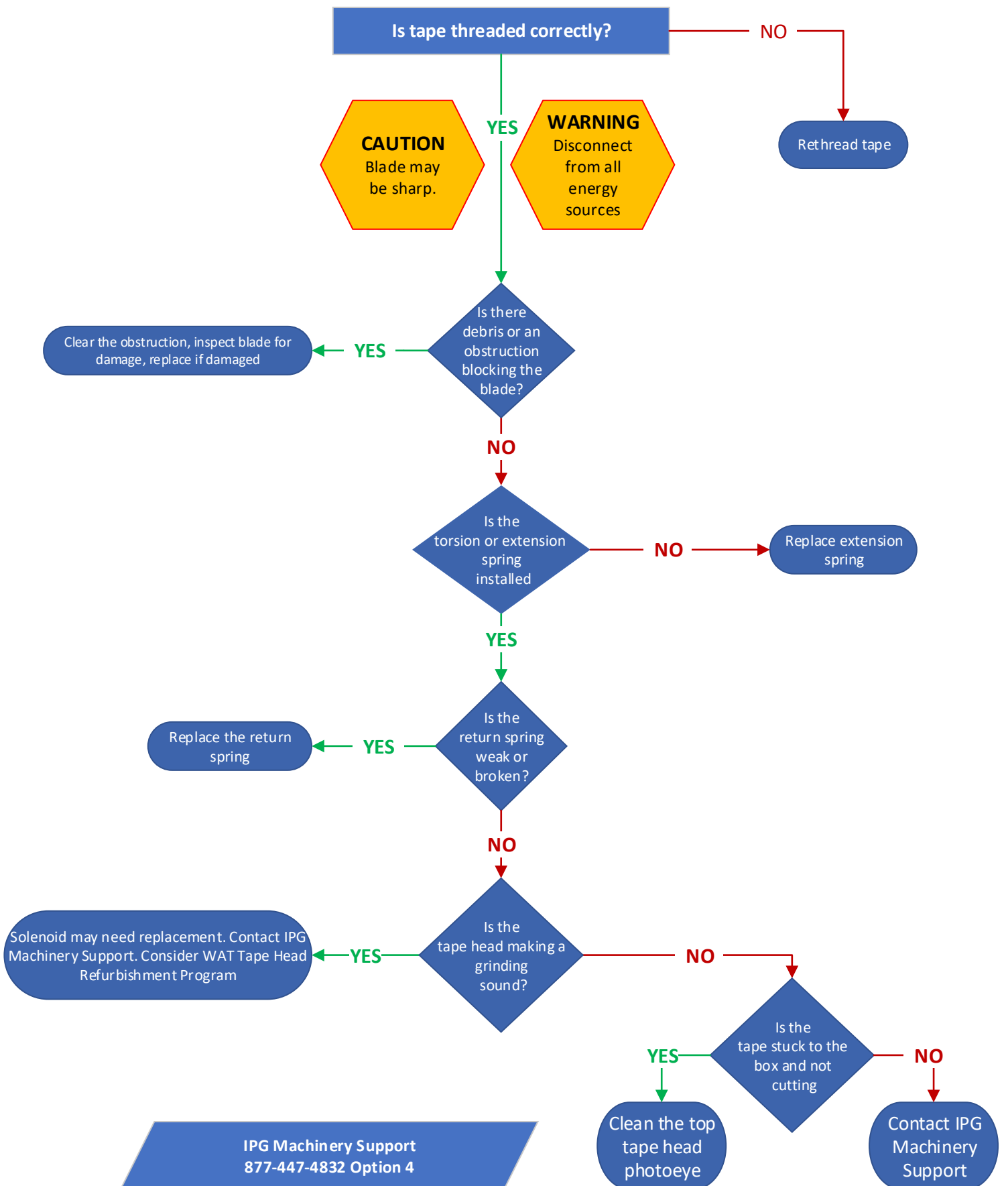

IPG Machinery Support  
877-447-4832 Option 4

## Tape Jam

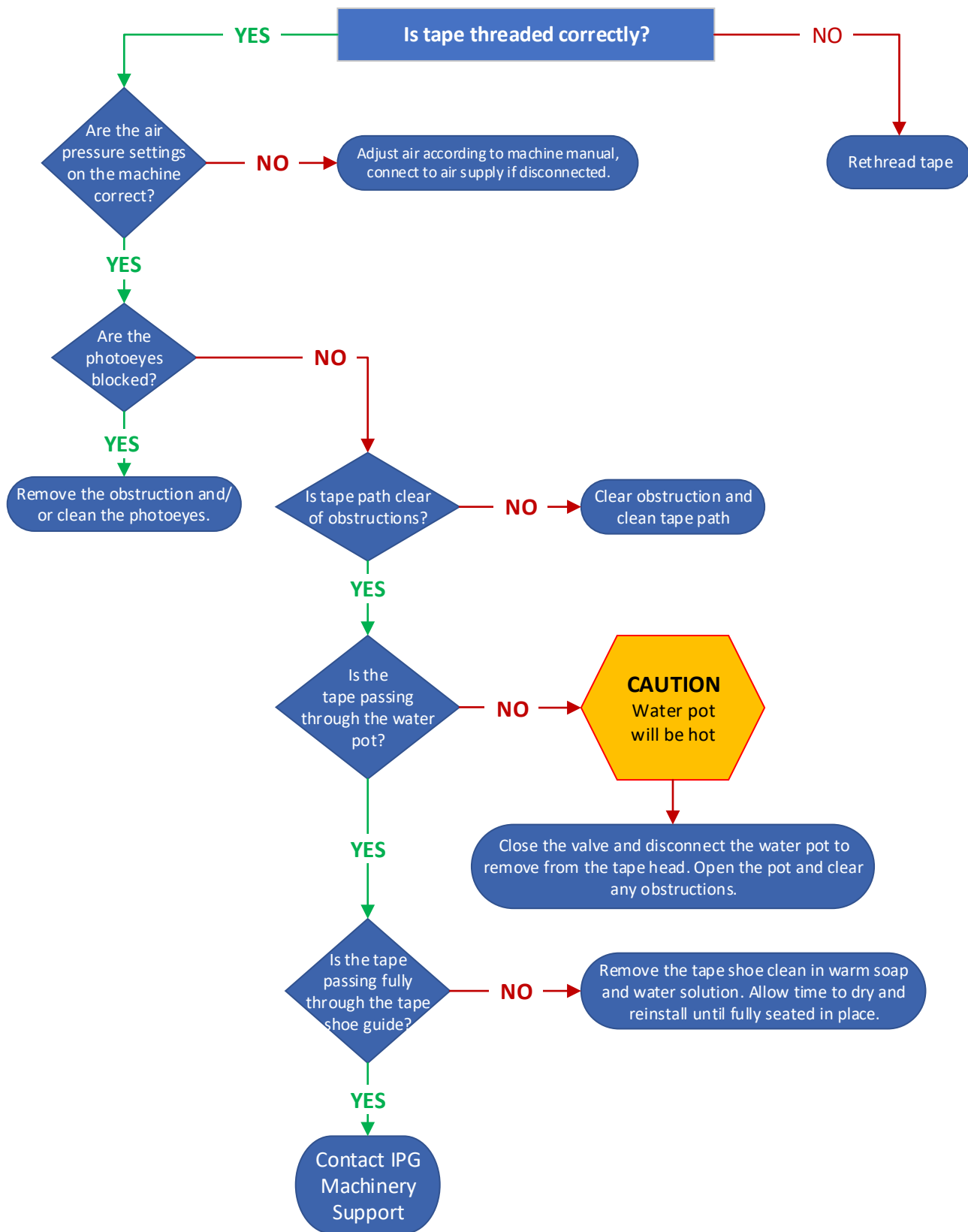

IPG Machinery Support  
877-447-4832 Option 4

## Wrinkles in the Tape

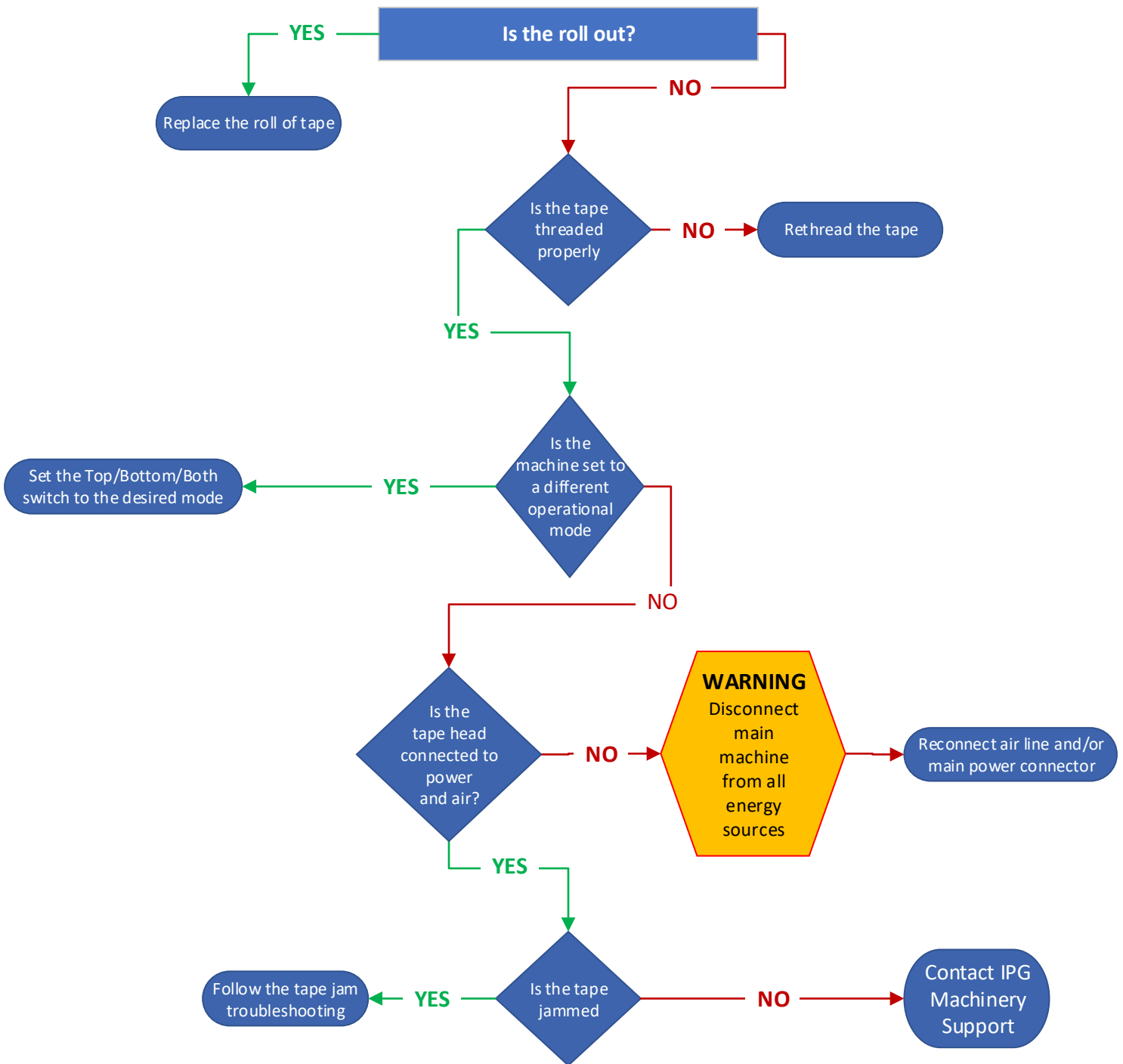

IPG Machinery Support  
877-447-4832 Option 4

# TROUBLESHOOTING

## Tape Not Dispensed

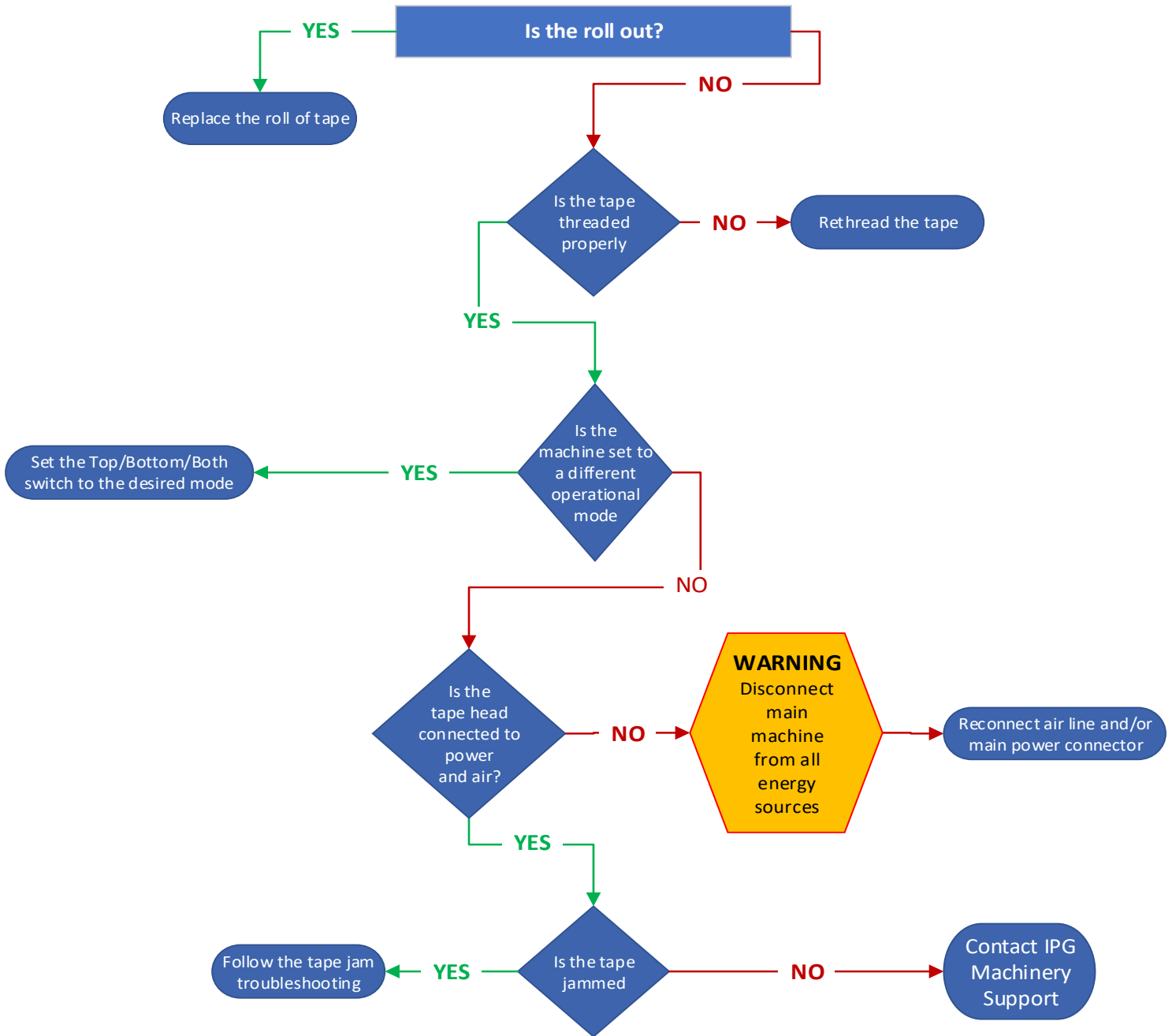

IPG Machinery Support  
877-447-4832 Option 4



# MAINTENANCE

The **USA 2024-WAT-BO** Case Sealer has been designed and manufactured with the finest components to provide long, trouble-free performance. General preventive maintenance will improve performance and prolong the life of the case sealer. Review the illustrations and chart below for information regarding machine maintenance.



**WARNING: TURN OFF ALL ENERGY SOURCES AND LOCK OUT THE ELECTRICAL SUPPLY BEFORE CLEANING OR MAINTENANCE. IF POWER CORDS AND PNEUMATIC CONNECTIONS ARE NOT DISCONNECTED, SEVERE INJURY TO PERSONNEL COULD RESULT.**

## Lubrication:

Spray centering guide shafts and compression guide shafts once a month with a silicone based dry film lubricant. This will not attract dust or lint from the surroundings.

Apply chain lube on the drive and centering guide chain once a month.

No other lubrication is necessary to operate the machine.

## Cleaning:

Cartons produce a sizable amount of dust and paper chips when processed or handled. If this dust is allowed to build up in the machine, it may cause component wear and overheating of motors. Remove the accumulated dust with a shop vacuum. Avoid using compressed air to remove the dust as this may cause the dust to penetrate into components.

Item	Action Required	Material	Frequency		
			Weekly	Monthly	Quarterly
Carton Dust In/On Machine	Vacuum off machine externally and internally, pay attention to drive base centering chain	Vacuum	X		
Hardware	Re-tighten any loose hardware, replace any missing hardware			X	
Cross Shafts	Lubricate	Dry PTFE		X	
Centering Chain	Lubricate	Chain Lubricant		X	
Air Regulator Filter	Clean filter	Water, Mild Detergent		X	
Tape Path	Clean to remove adhesive	Water, Mild Detergent	X		
Water Pot/Reservoir	Rinse out thoroughly	Water, Mild Detergent		X	
Wetting Roller	Clean roller	Water, Mild Detergent			
Wipe Down Drive Rollers	Remove dust	Air Hose	X		
Tape Head Assist Roller	Clean roller	Water, Mild Detergent	X		

## Recommended Spare Parts:

It is recommended to keep a small supply of spare parts on hand in order to reduce any potential down time for maintenance. The table of parts to the right is the recommended list of spare parts. Different applications of machinery may require some amendments to this list, please consult IPG Machinery Support for any additional recommended material.

Description	Item Number	QTY
Peel off Spring	<a href="#">UPH1289</a>	1
Emergency Stop Button	<a href="#">UPM2211</a>	1
Driving Belts	<a href="#">UPM4884</a>	2
Water Pot Roller	<a href="#">WET0071</a>	1
WAT Tape Head Roller	WPT0144	2
Striker Plate	<a href="#">WPT0044</a>	1
Cutter Blade	<a href="#">WPT0050</a>	1
Extension Spring	WPT0063	1

# MAINTENANCE

## Changing the Air Regulator Filter

The filter on the air regulator removes dirt and moisture from supplied air before it enters the carton sealer.

1. To remove metal protective guard, press down on locking tab located towards the top of the guard, rotate guard and pull down.
2. The clear reservoir has a threaded top, which is used to attach it to the main regulator assembly. To remove the reservoir, rotate it until unfastened.
3. The air regulator filter is held in place using a threaded cap fastened on to the main assembly. To remove the filter, unfasten the cap and pull down on filter.

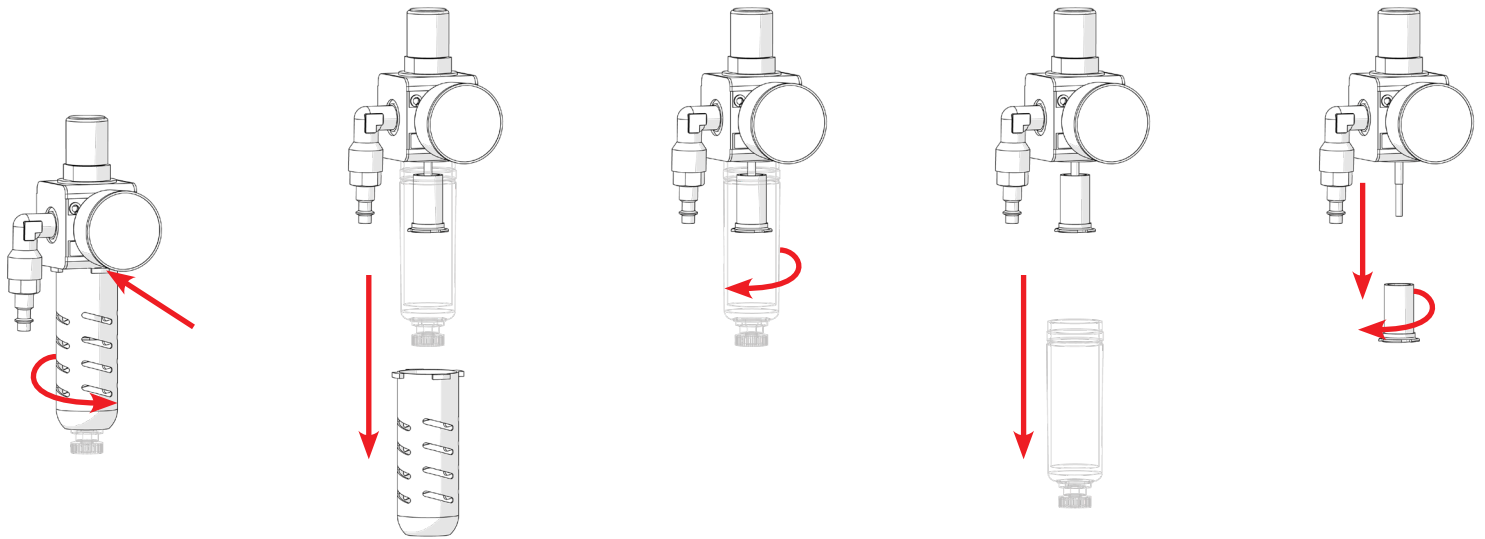
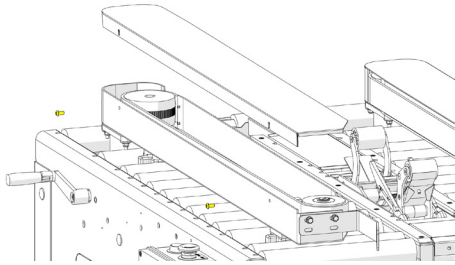

Figure 75: Air Filter Regulator

# MAINTENANCE

## Drive Belt Adjustment

1. Using a 4mm Allen key, remove two screws and remove drive base cover.



**Figure 83: Drive Base Cover**

2. Using appropriate Allen key and wrench, tighten belt tensioning bolts. Be sure to equally adjust tensioning bolts for both drive belts.

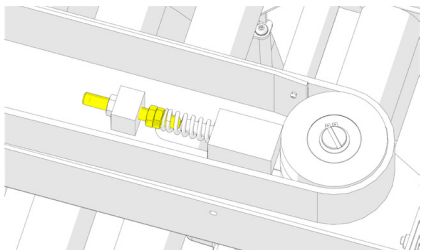

**Figure 84: Tighten Belt Tension Bolt**

3. Proper belt tension is achieved when a 5-pound pull force is used to create a 25mm (1 in.) gap, as shown in the middle of the drive base.

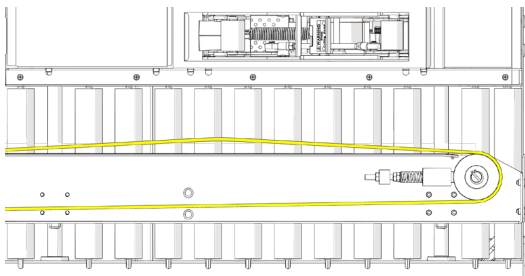

**Figure 85: Proper Belt Tension**

4. Intertape S/B drive idler pulleys are engineered to self-track to center. After tensioning, if the belts do not track on center, contact maintenance or your IPG Distributor.

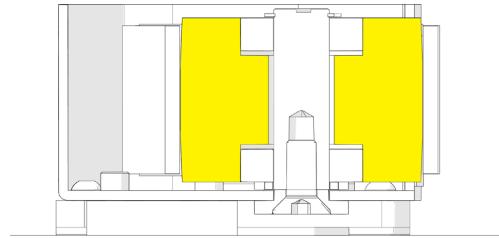

**Figure 86: Self-Center Pulley**

5. Using a 4mm Allen key, replace drive base cover, as shown.

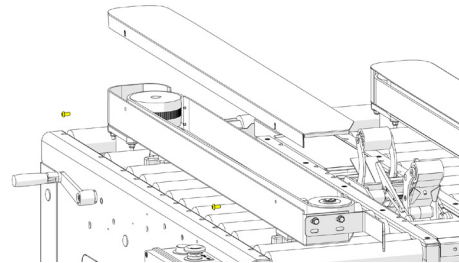
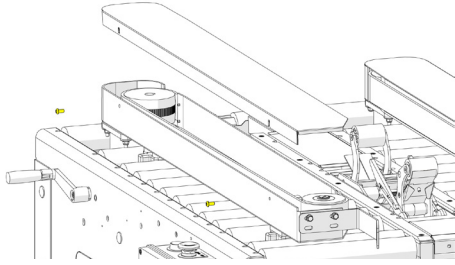

**Figure 87: Drive Base Cover**

# MAINTENANCE

## Drive Belt Replacement

1. Using a 4mm Allen key, remove two screws and remove drive base cover.



**Figure 76: Drive Base Cover**

2. Using appropriate Allen key and wrench, loosen belt tensioning bolts.

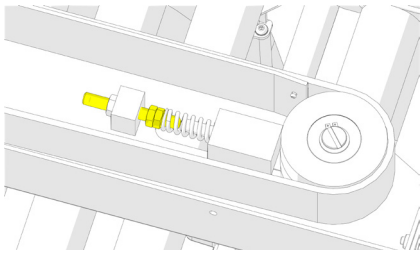

**Figure 77: Loosen Belt Tension Bolt**

3. Remove worn belt and replace with new belt.

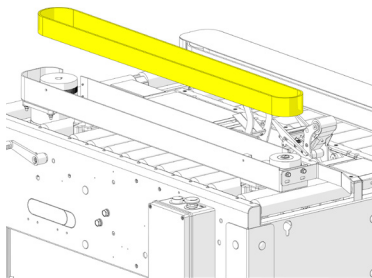

**Figure 78: Replace Belt**

4. Using appropriate Allen key and wrench, tighten belt tensioning bolts. Be sure to equally adjust tensioning bolts for both drive belts.

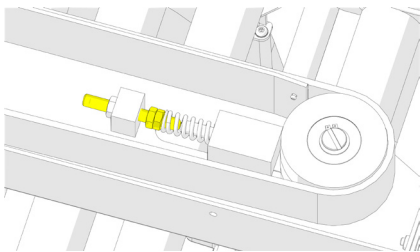

**Figure 79: Tighten Belt Tension Bolt**

5. Proper belt tension is achieved when a 5-pound pull force is used to create a 25mm (1 in.) gap, as shown in the middle of the drive base.

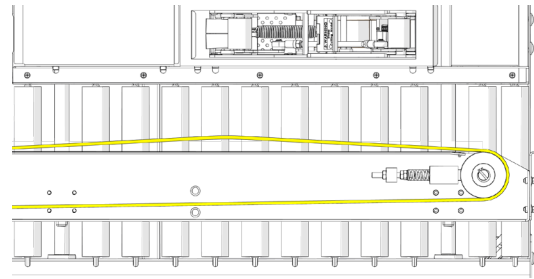

**Figure 80: Proper Belt Tension**

6. Intertape S/B drive idler pulleys are engineered to self-track to center. After tensioning, if the belts do not track on center, contact maintenance or your IPG Distributor.

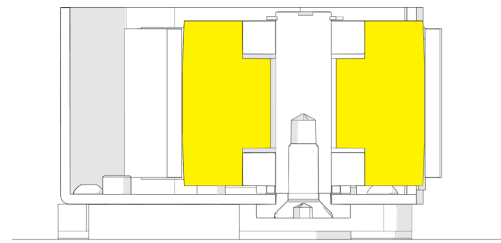

**Figure 81: Self-Center Pulley**

7. Using a 4mm Allen key, replace drive base cover, as shown.

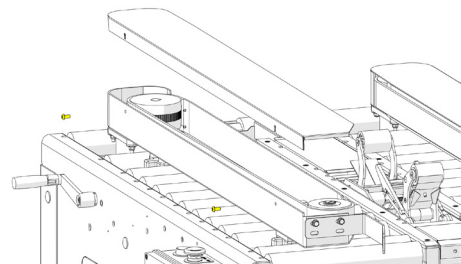

**Figure 82: Drive Base Cover**

# APPENDIX A

## Electrical Drawing

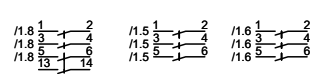
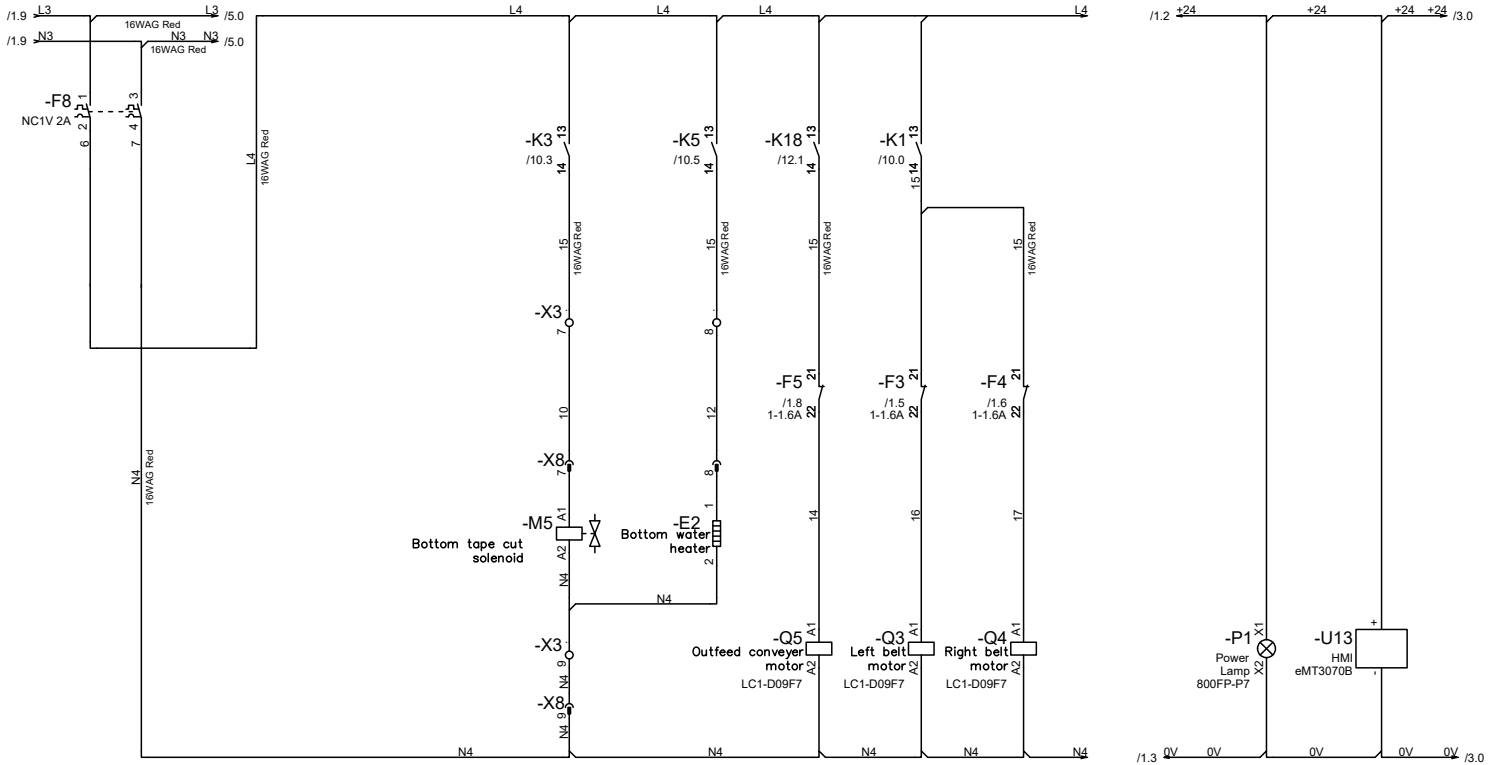
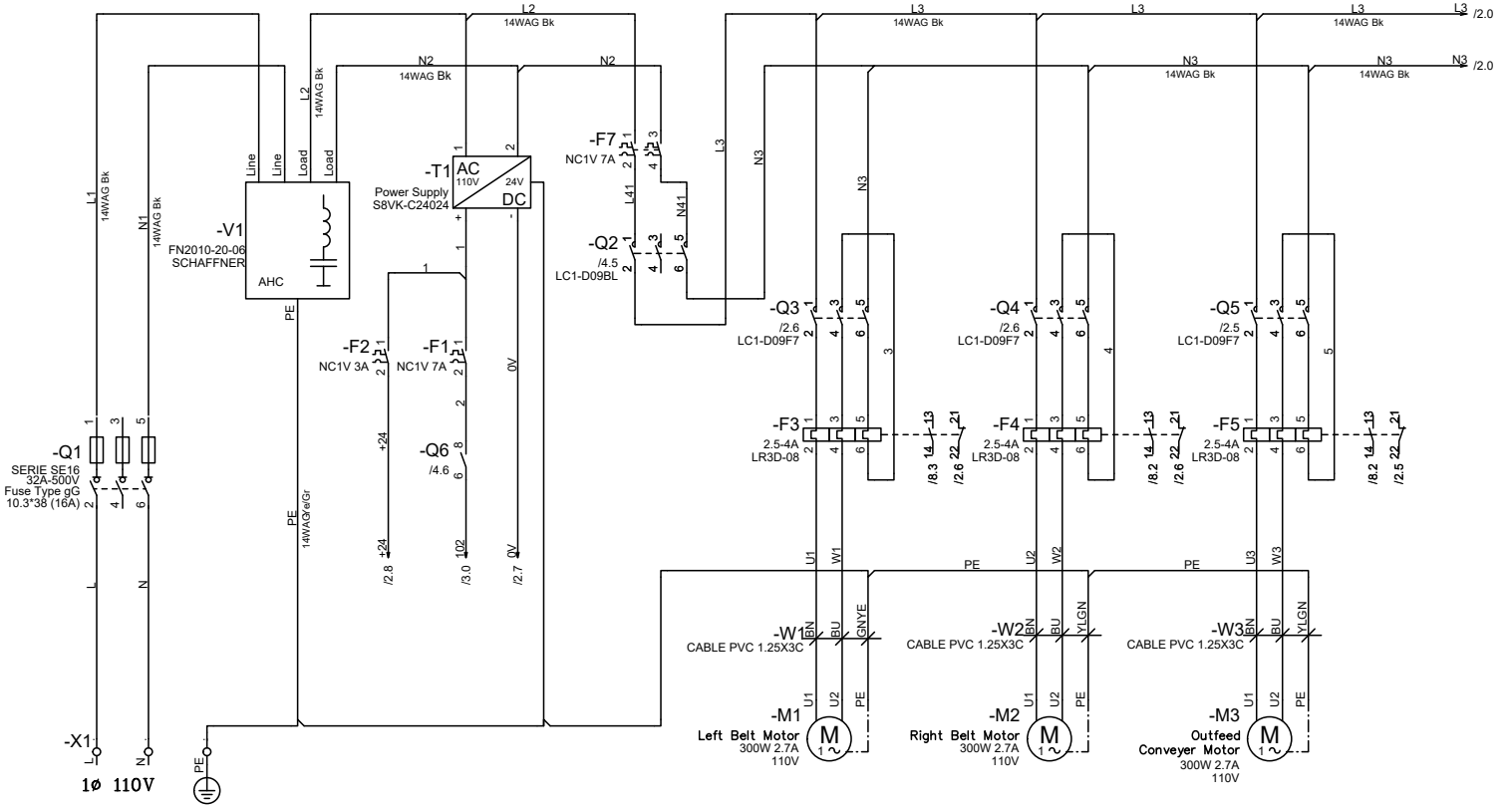

# APPENDIX A

## Electrical Drawing

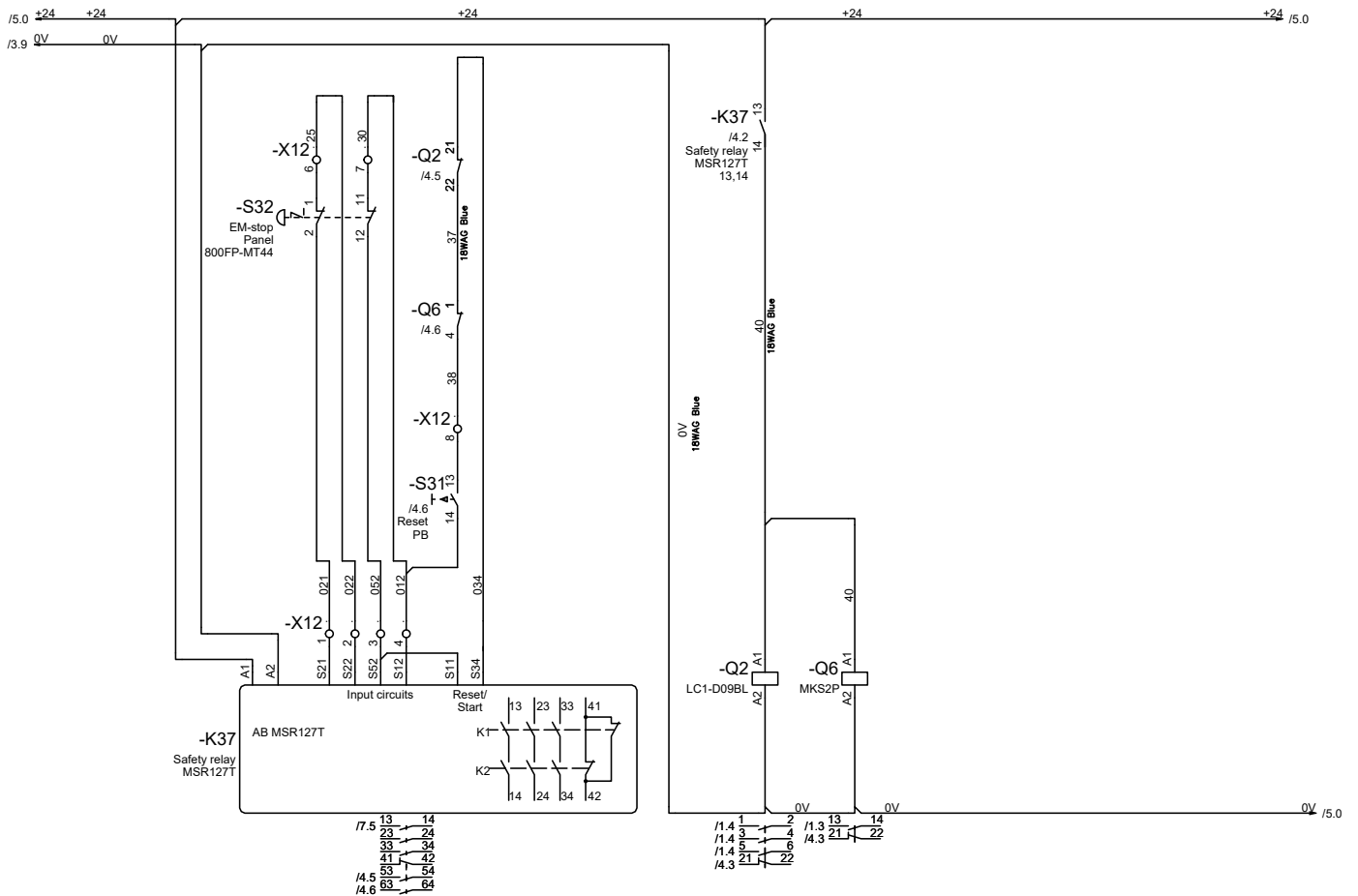
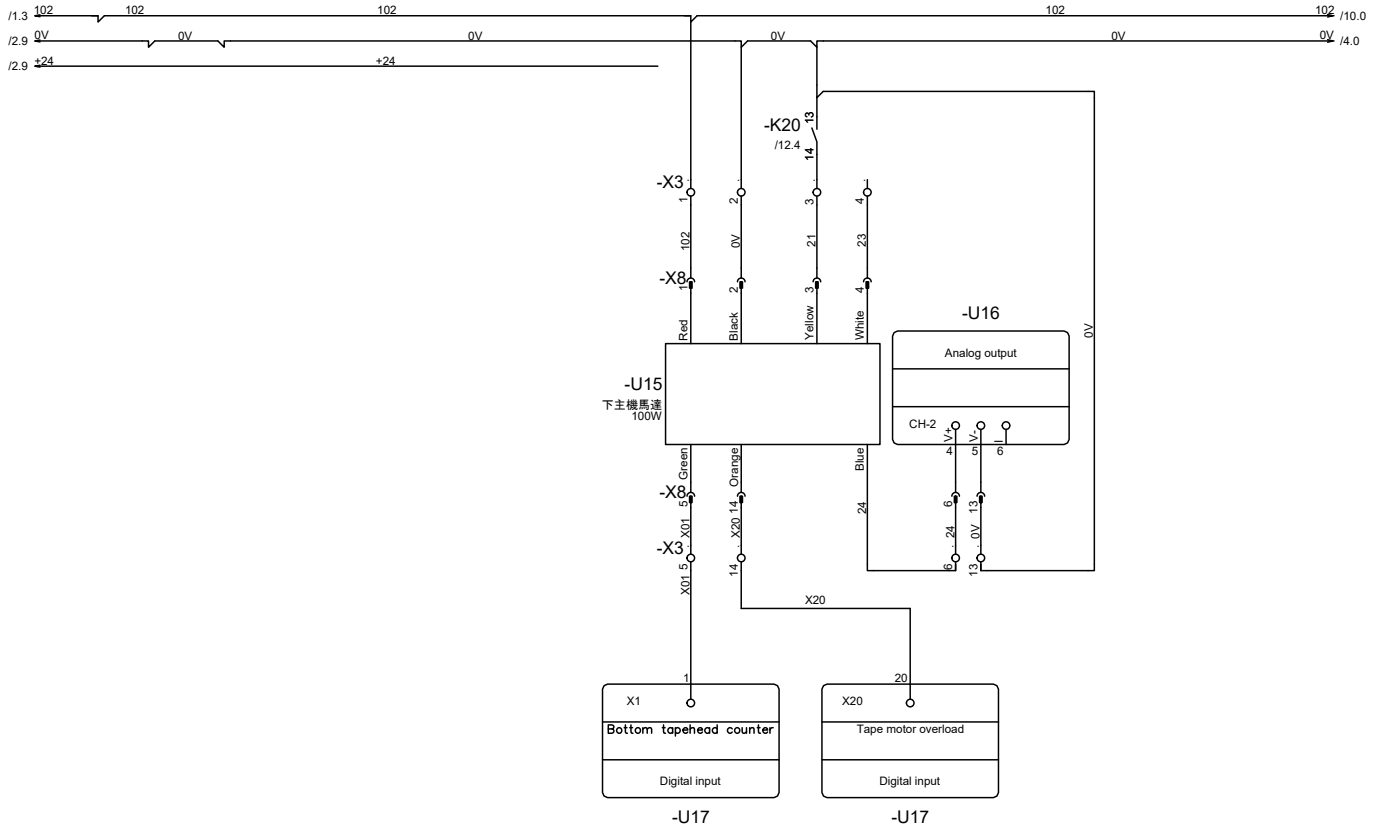

# APPENDIX A

## Electrical Drawing

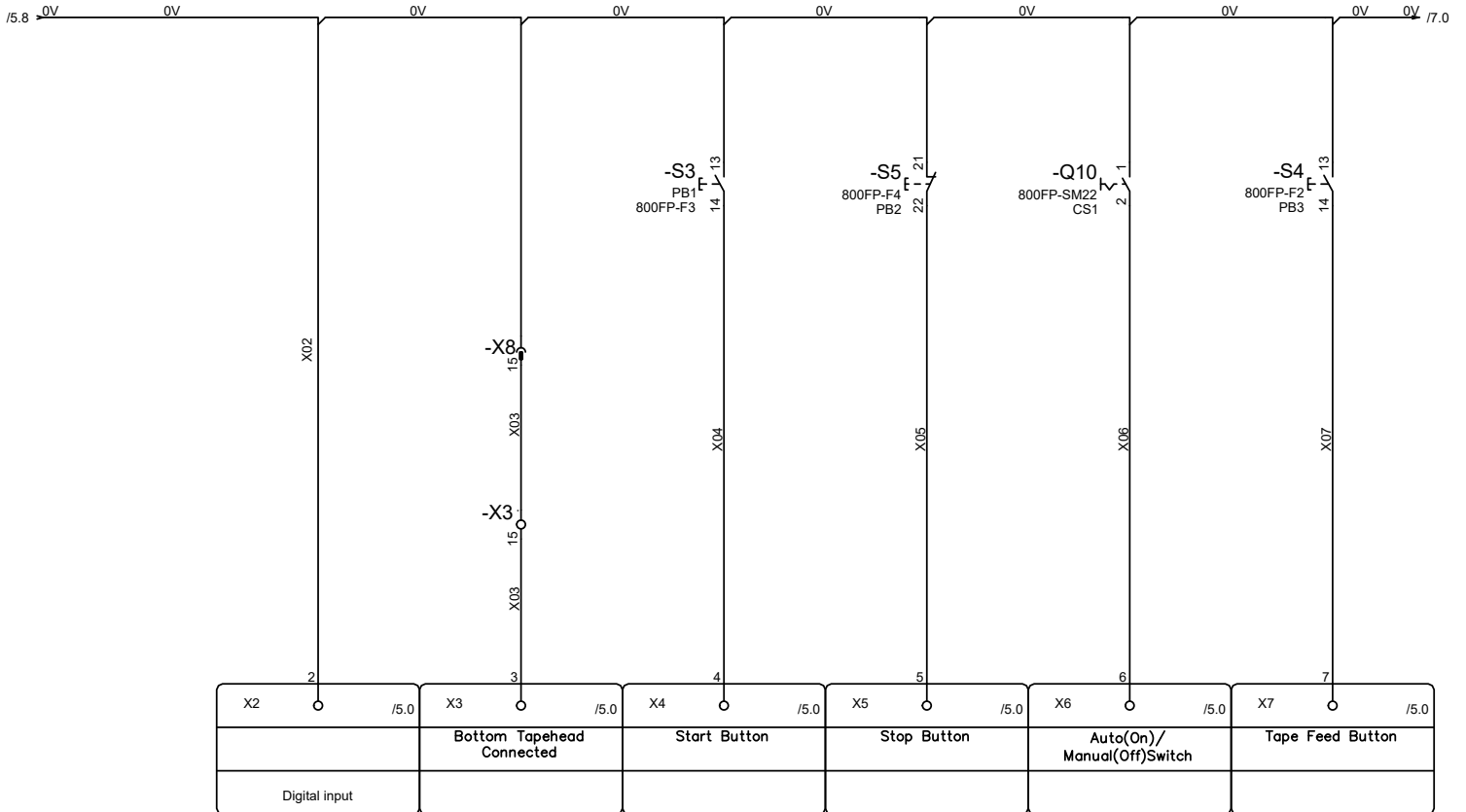
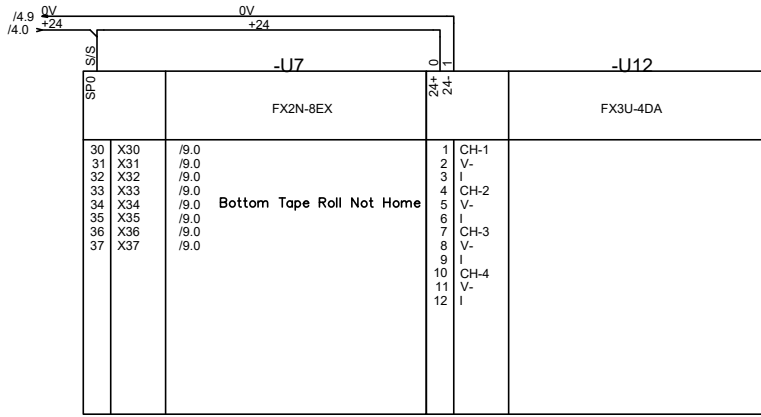
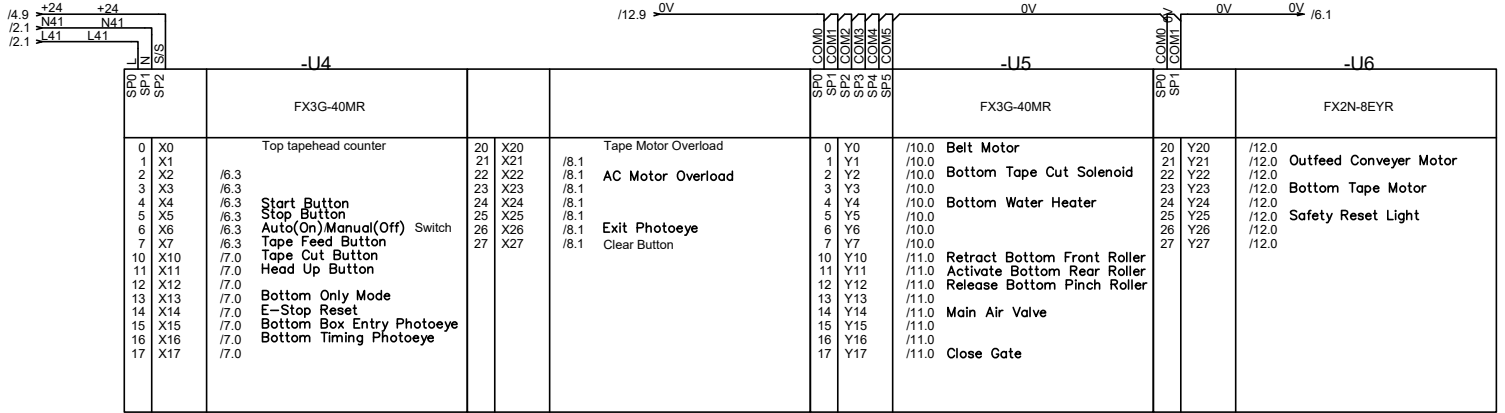

-U4

# APPENDIX A

## Electrical Drawing

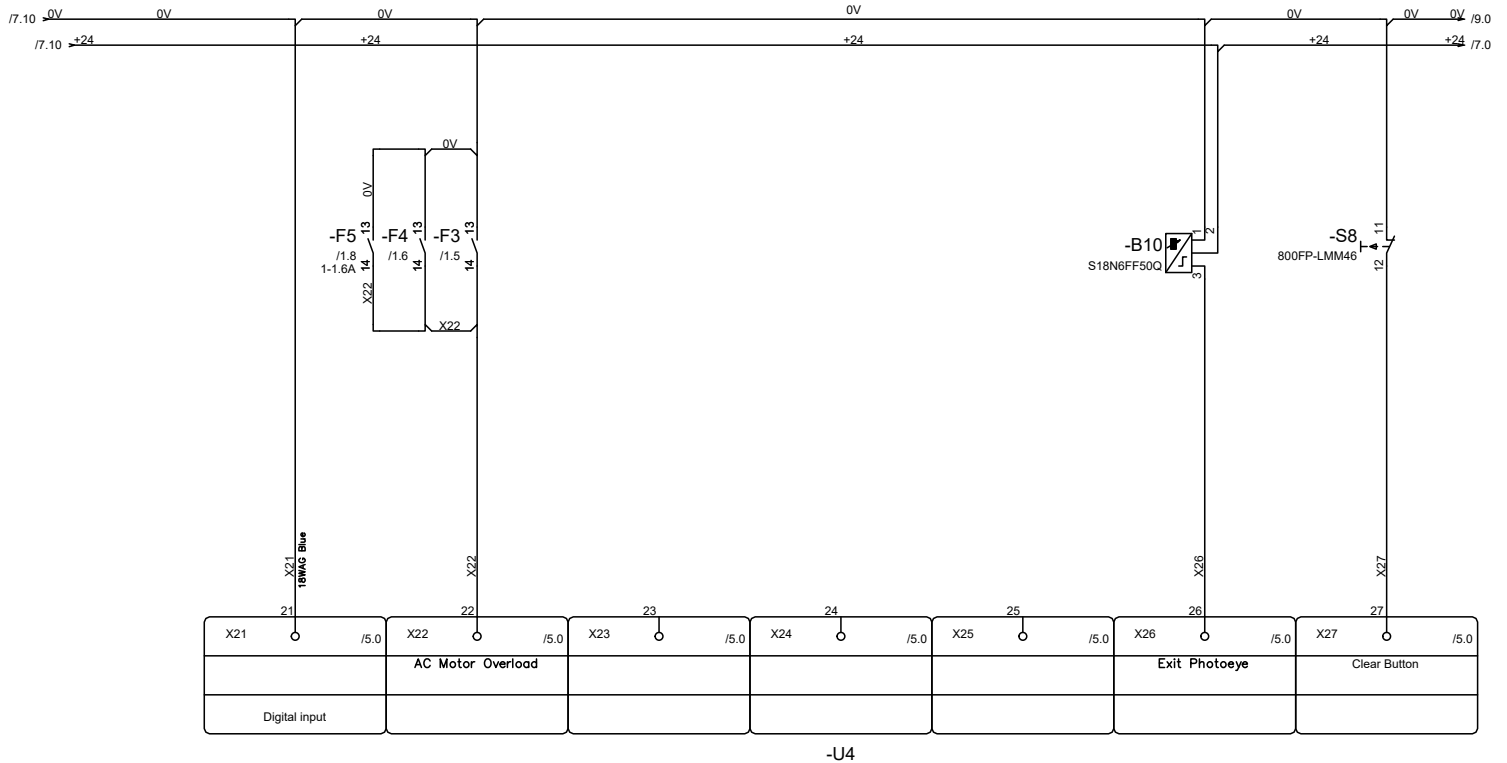
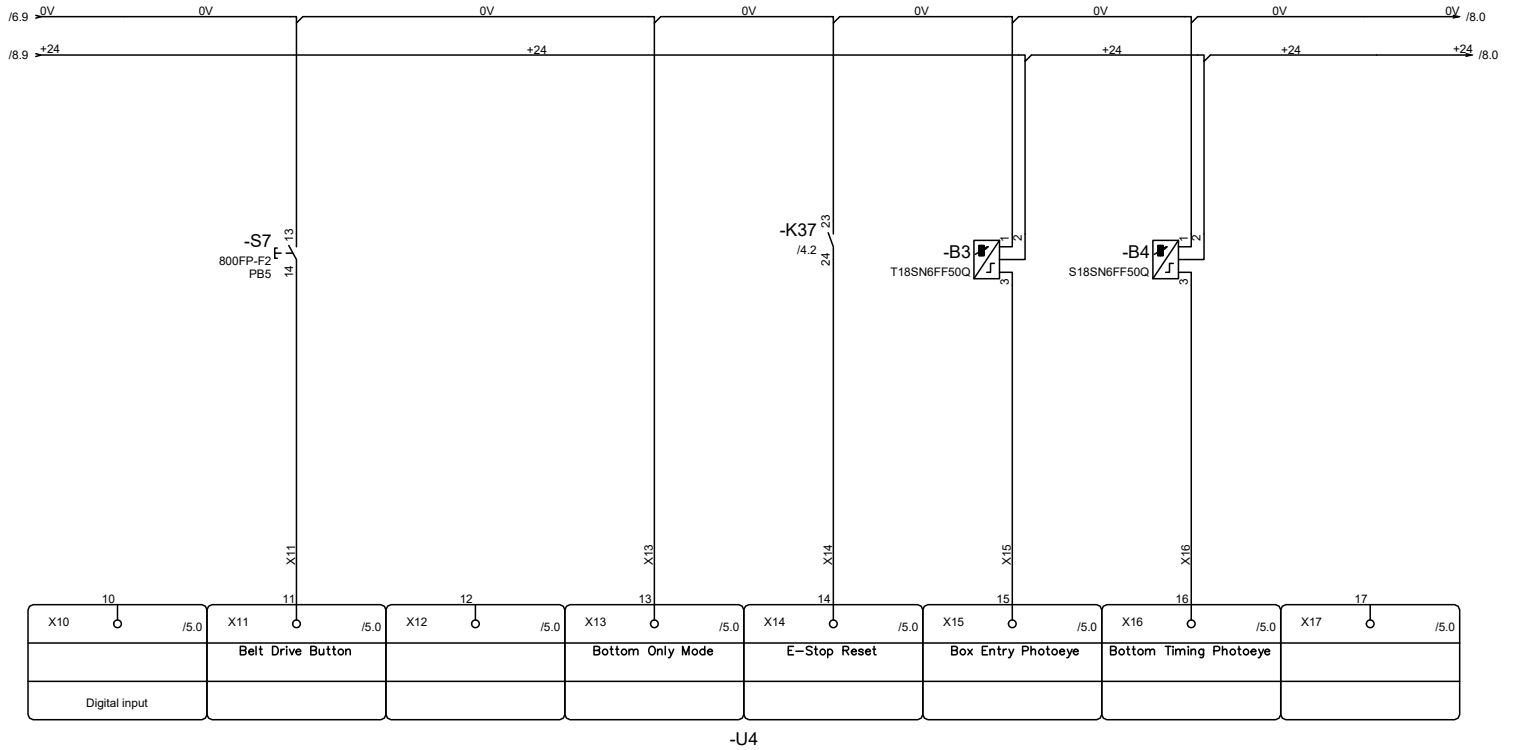



# APPENDIX A

## Electrical Drawing

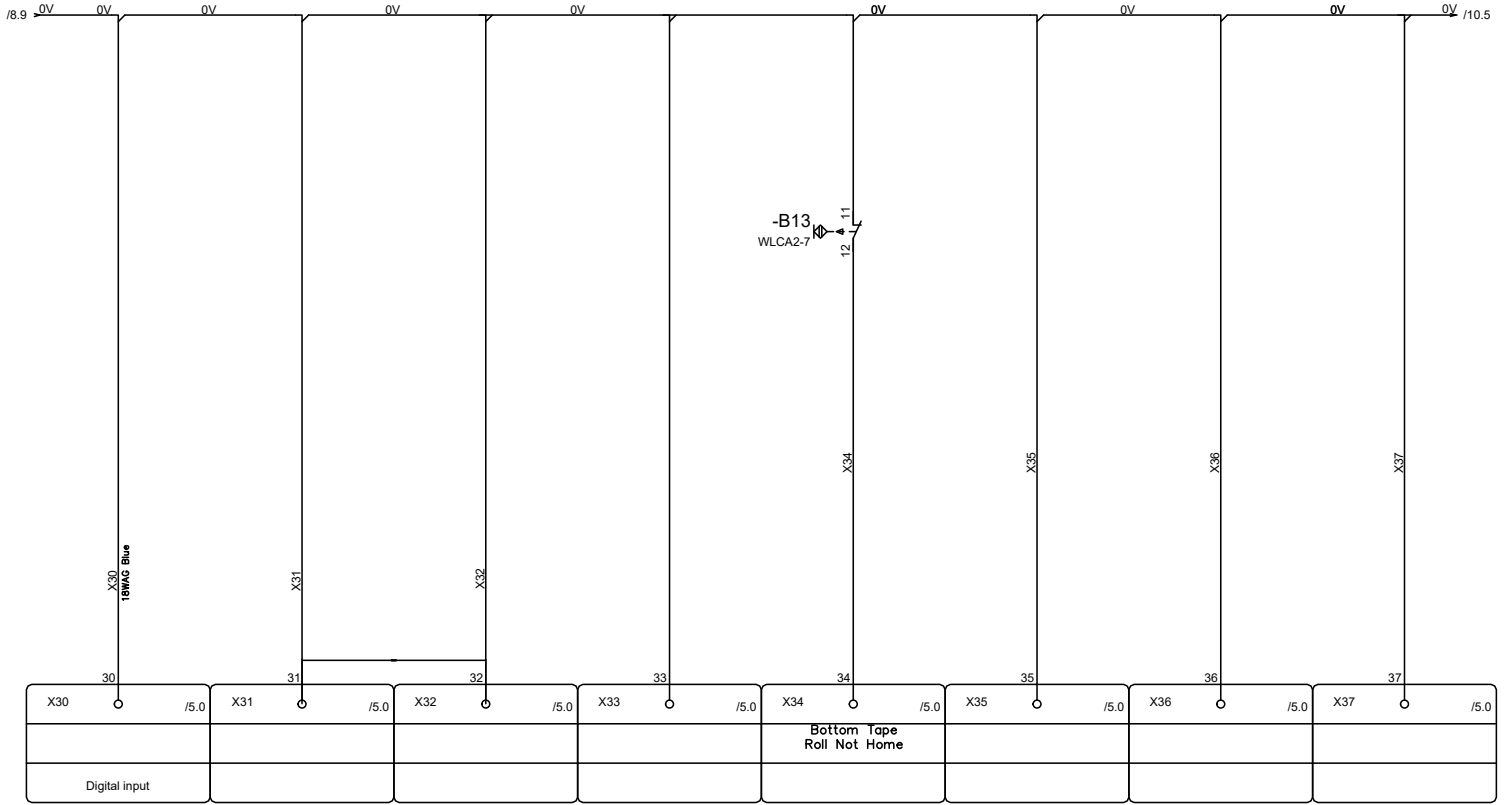

-U7

-U5

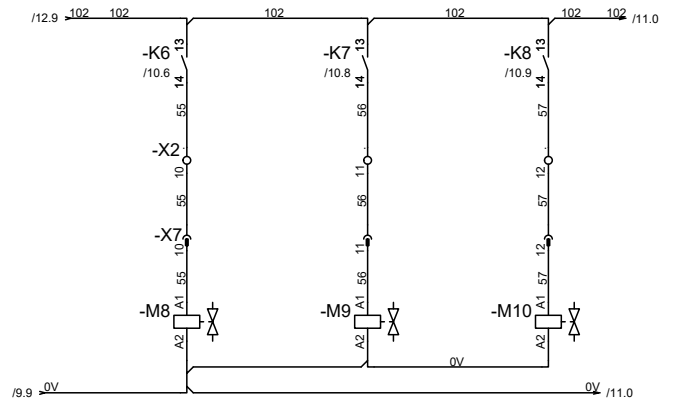
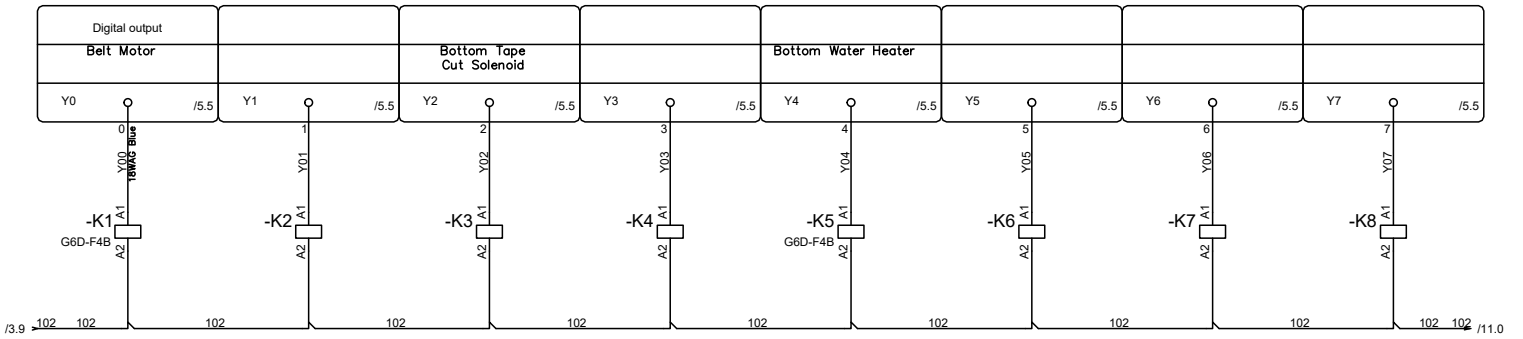

/2.2 13 14

/2.4 13 14

/2.3 13 14

/2.4 13 14

/10.6 13 14

/10.8 13 14

/10.9 13 14

# APPENDIX A

## Electrical Drawing

-U5

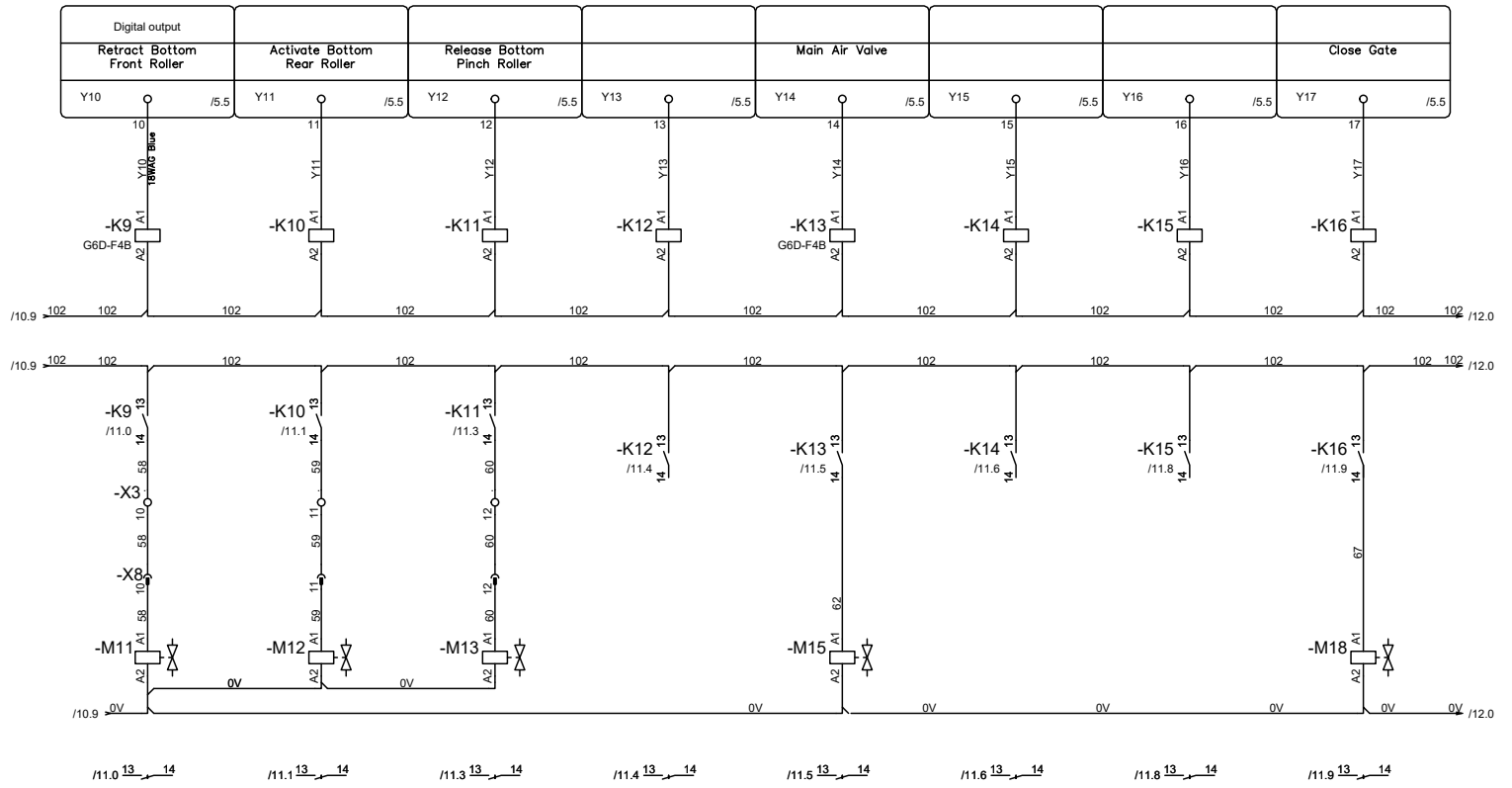

-U6

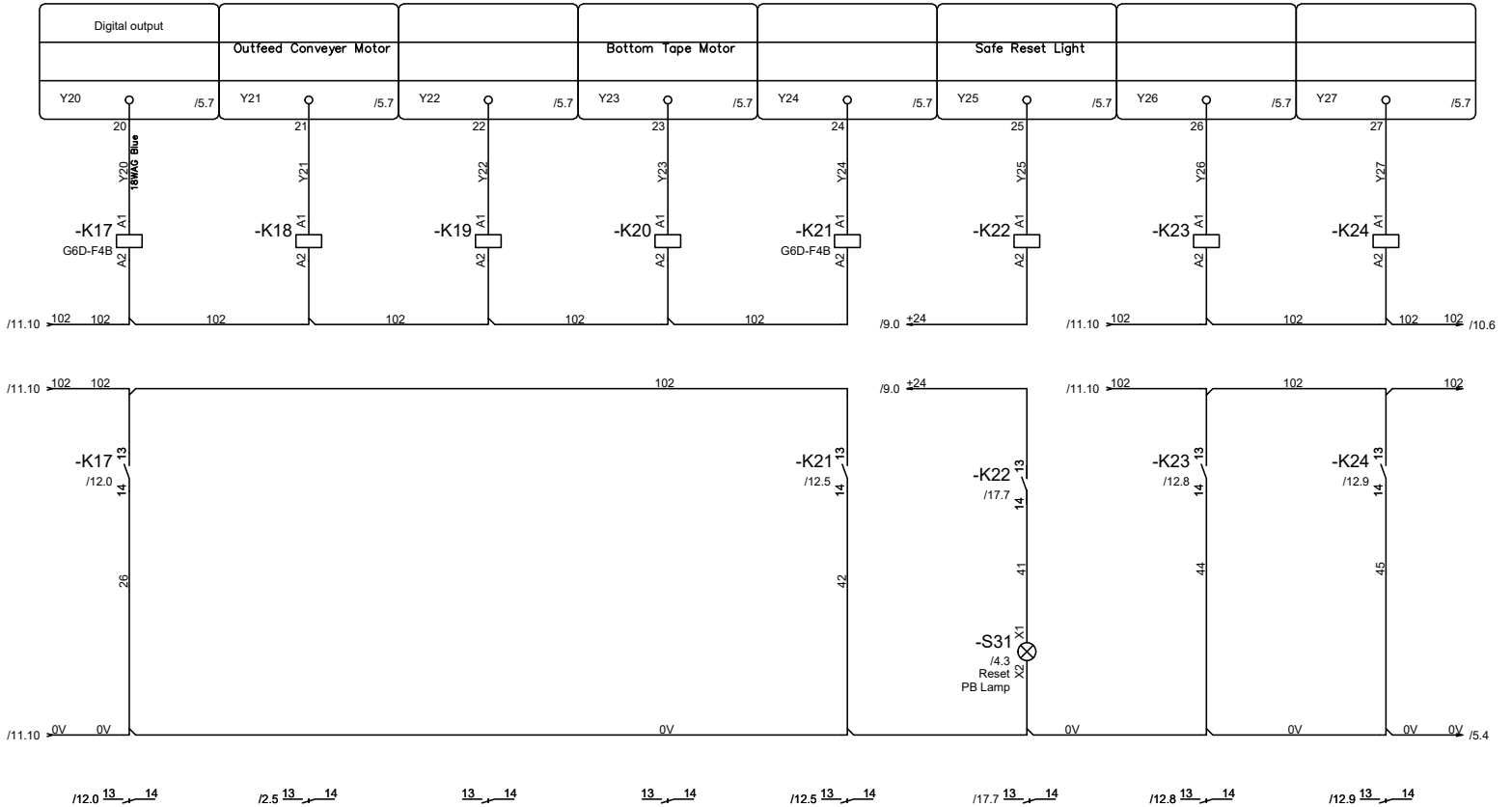

# APPENDIX A

## Electrical Drawing

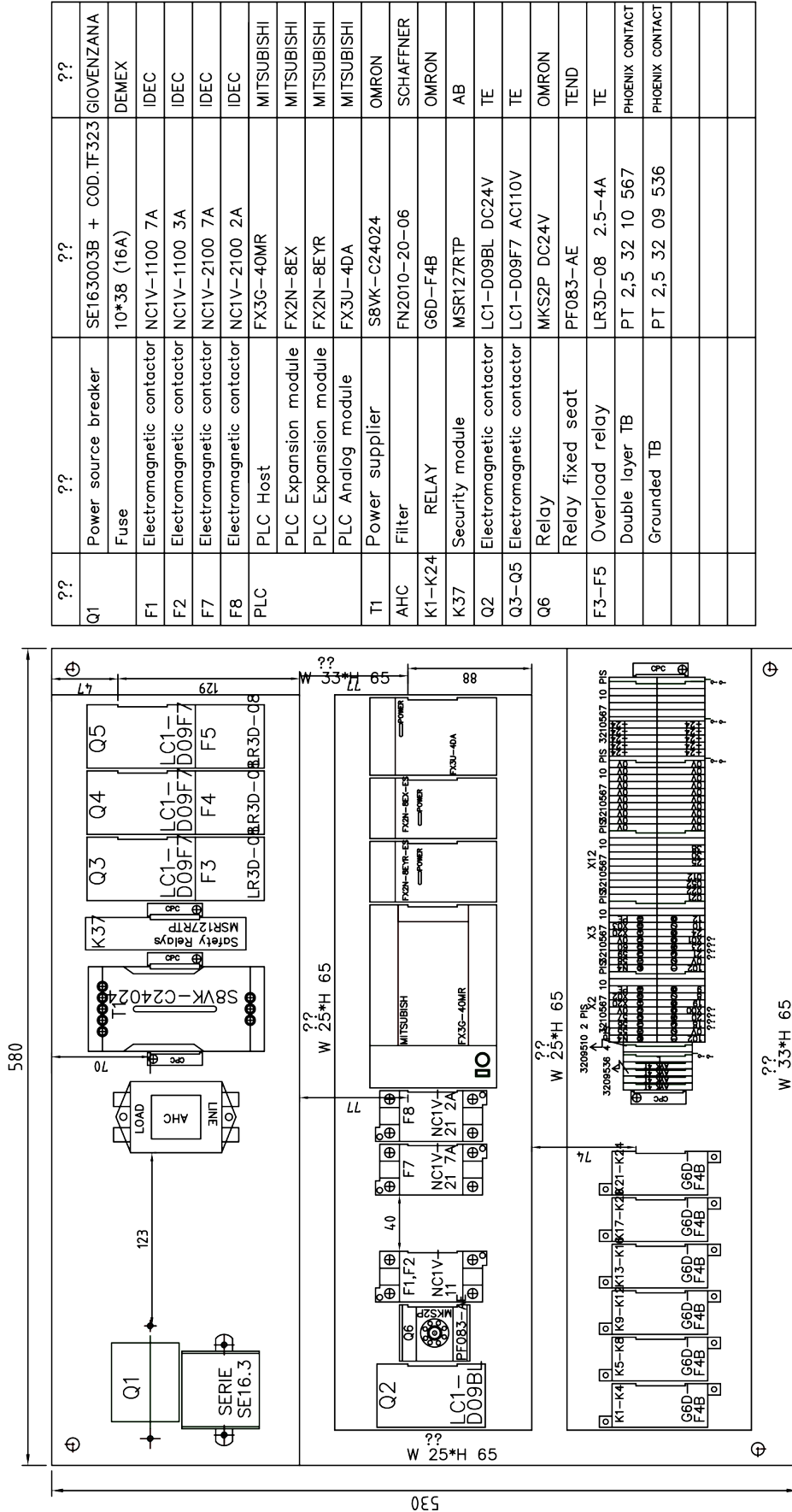

# APPENDIX A

## Electrical Drawing

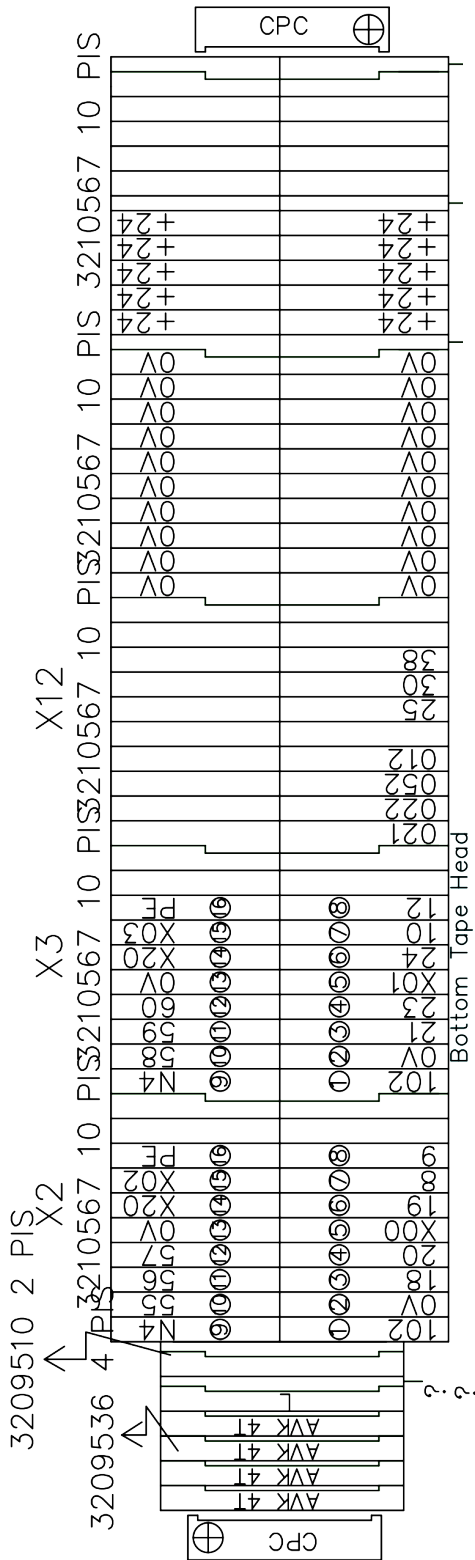

MACHINE CONNECTION		TAPE HEAD CONNECTION	
16	→ PE	16	← PE
15	→ X03	15	← 0V
14	→ X20	14	← X20
13	→ 0V	13	← 0V
12	→ 60(Pitch Roller)	12	← 60(Pitch Roller)
11	→ 59(Rear Roller)	11	← 59(Rear Roller)
10	→ 58(Front Roller)	10	← 58(Front Roller)
9	→ N4	9	← N4
8	→ 12(Heater)	8	← 12(Heater)
7	→ 10(Tape Cut)	7	← 10(Tape Cut)
6	→ Blue(24)	6	← Blue(24)
5	→ Green(X01)	5	← Green(X01)
4	→ White(23)	4	← White(23)
3	→ Yellow(21)	3	← Yellow(21)
2	→ Black(0V)	2	← Black(0V)
1	→ Red(102)	1	← Red(102)

# APPENDIX A

## Pneumatic Drawing

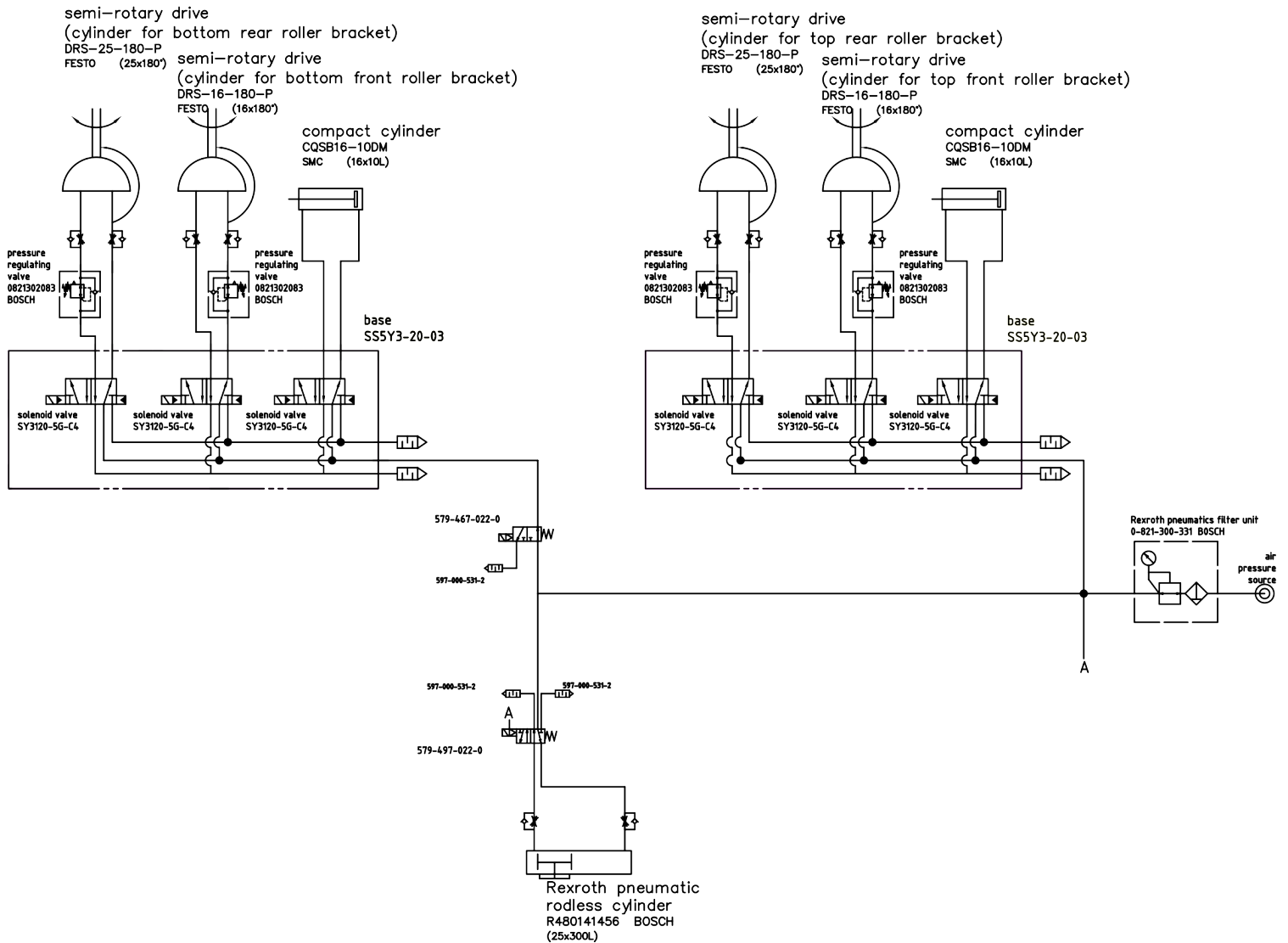

# APPENDIX B

## Parts Listing

USA 2024-WAT	71
Base Assembly	72
Bottom Water Assembly	73
Machine Frame Assembly	74
Main Leg Assemblies	75
Pneumatic Assemblies	76
Centering Assembly 1	77
Centering Assembly 2	78
Bridge Conduit	79
Exit Plate	80
Cover Plates	81
Entry Plate	82
Rollers	83
Base Assembly	84
Leg Assembly	85
Centering Assembly	86
Machine Frame	87
Powered Exit Table	88
Exit Table Leg Without Emergency Stop	89
Exit Table Leg With Emergency Stop	90
Exit Table Roller Assembly	91
Bottom Tape Mandrel Assembly	92
Electrical Cabinet Assembly 1	93
Electrical Cabinet Assembly 2	94
Bridge Assembly	95
Top Squeezer Assemblies	96
Bridge Locking Assembly	97
Bridge Sub Assembly 1	98
Bridge Sub Assembly 2	99
Top Tape Mandrel Assembly	100
Cross Bar Assembly	101
Tape Mandrel Assembly	102
Dancer Bar Assembly	103
Top Clutch Assembly	104
Top Water Assembly	105

Items with black balloon call outs are assemblies (made of more than one individual part).

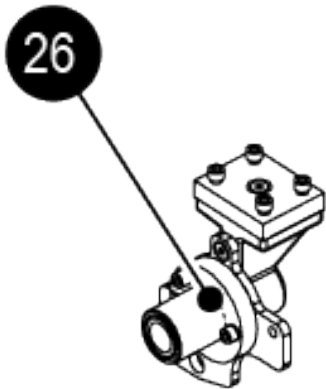

Items with white balloon call outs are single parts.

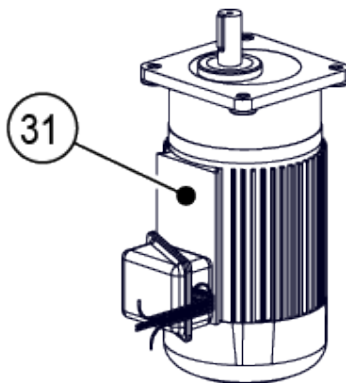

The top right of each page with a parts breakdown will show a red highlighted section of the machine that is being broken out into more detail.

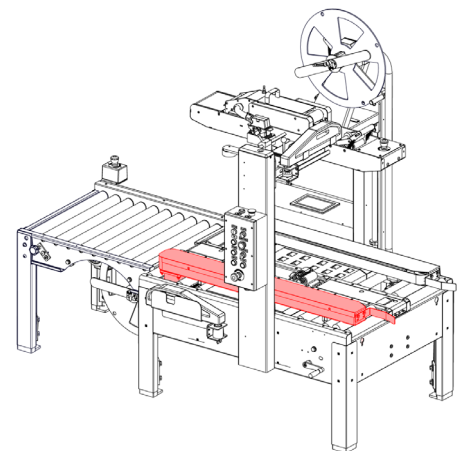

Not all assemblies are sold as assemblies please consult IPG Machine Support for details.

# APPENDIX B

## USA 2024-WAT

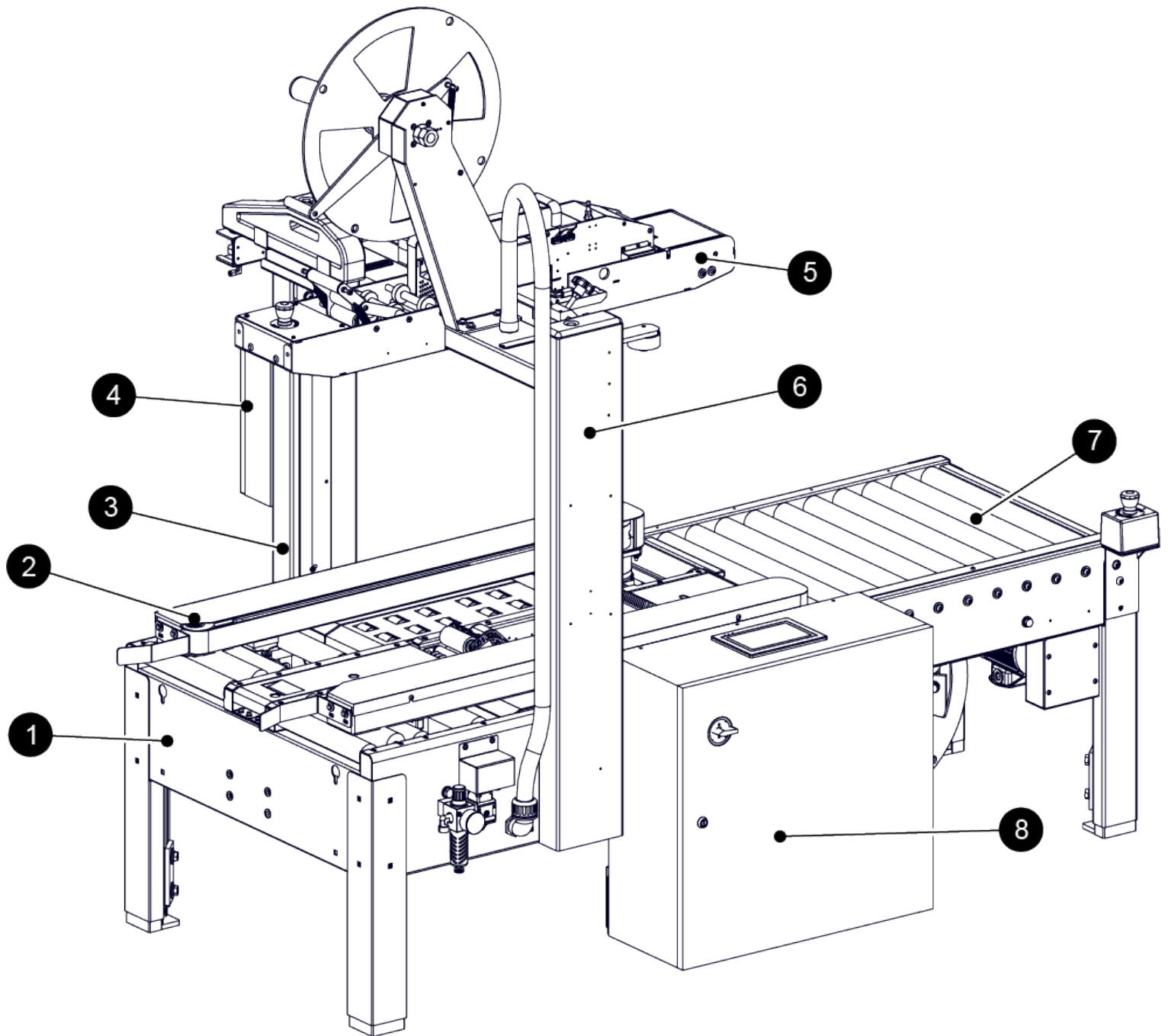

ITEM	PART #	DESCRIPTION	QTY
1	USM0867	BASE ASSEMBLY	1
2	UAM0510	DRIVE UNIT, L.H	1
3	UAM0670	COLUMN ASSEMBLY L.H.	1
4	UAM0488	CONTROL BOX	1
5	UAM0512	BRIDGE ASSEMBLY	1

ITEM	PART #	DESCRIPTION	QTY
6	UAM0487	COLUMN ASSEMBLY, R.H.	1
7	UAM0489	OUTPUT TABLE	1
8	UAM0671	ELECTRICAL BOX	1

# APPENDIX B

## Base Assembly

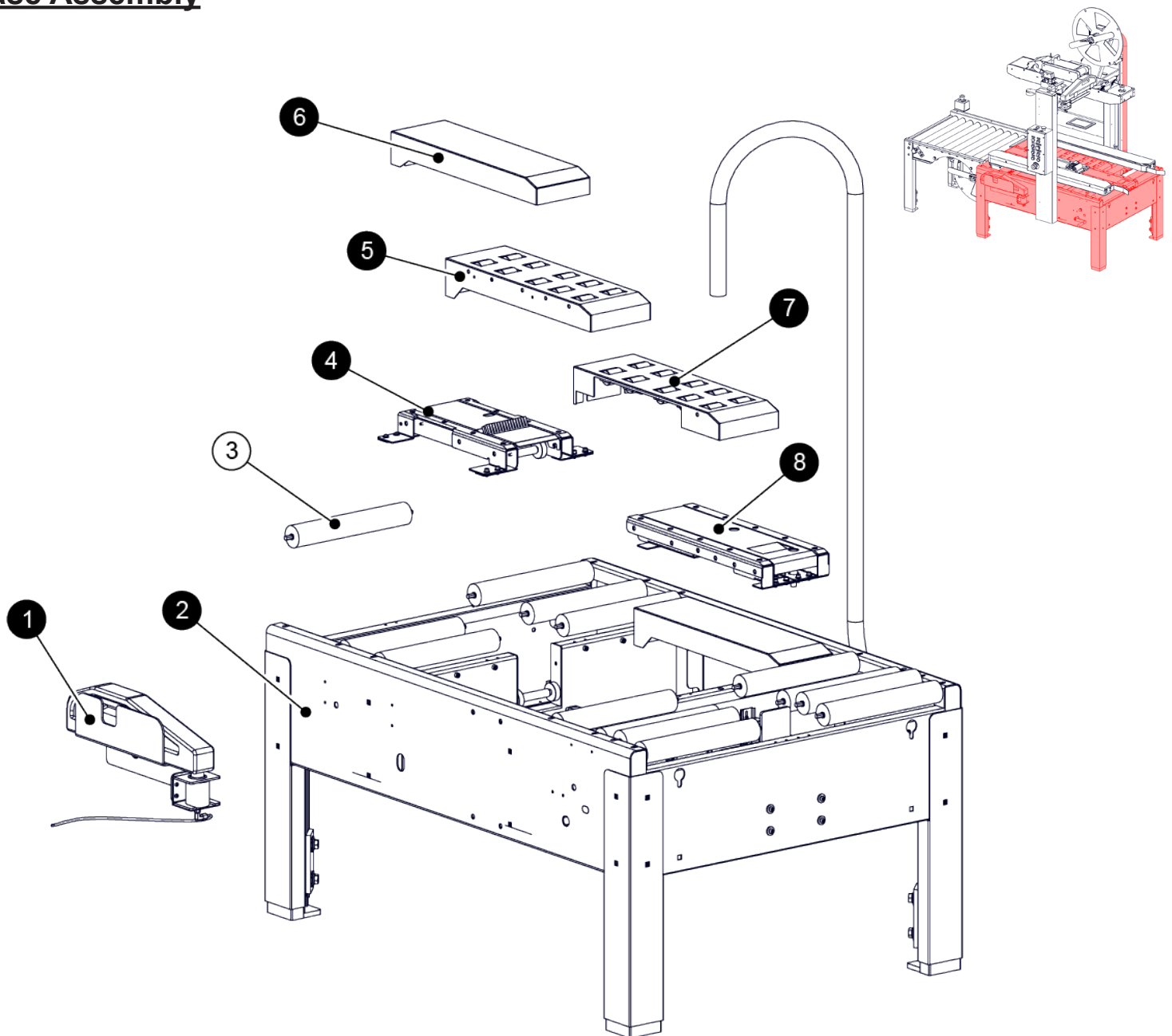

ITEM	PART NUMBER	DESCRIPTION	QTY
1	USM0901	WATER BOTTLE UNIT ASS'Y	1
2	UAM0468	FRAME ASSEMBLY	1
3	UPM3226	PVC ROL CHARCOAL DIA 1.9 X 12.00	14
4	UAM0478	OUTLET TABLE ASSEMBLY	1
5	UAM0474	ROLLER ASSEMBLY, L.H.	1
6	UPM4930	SIDE COVER	2
7	UAM0477	ROLLER ASSEMBLY, R.H.	1
8	UAM0473	INLET TABLE ASSEMBLY	1



# APPENDIX B

## Bottom Water Assembly

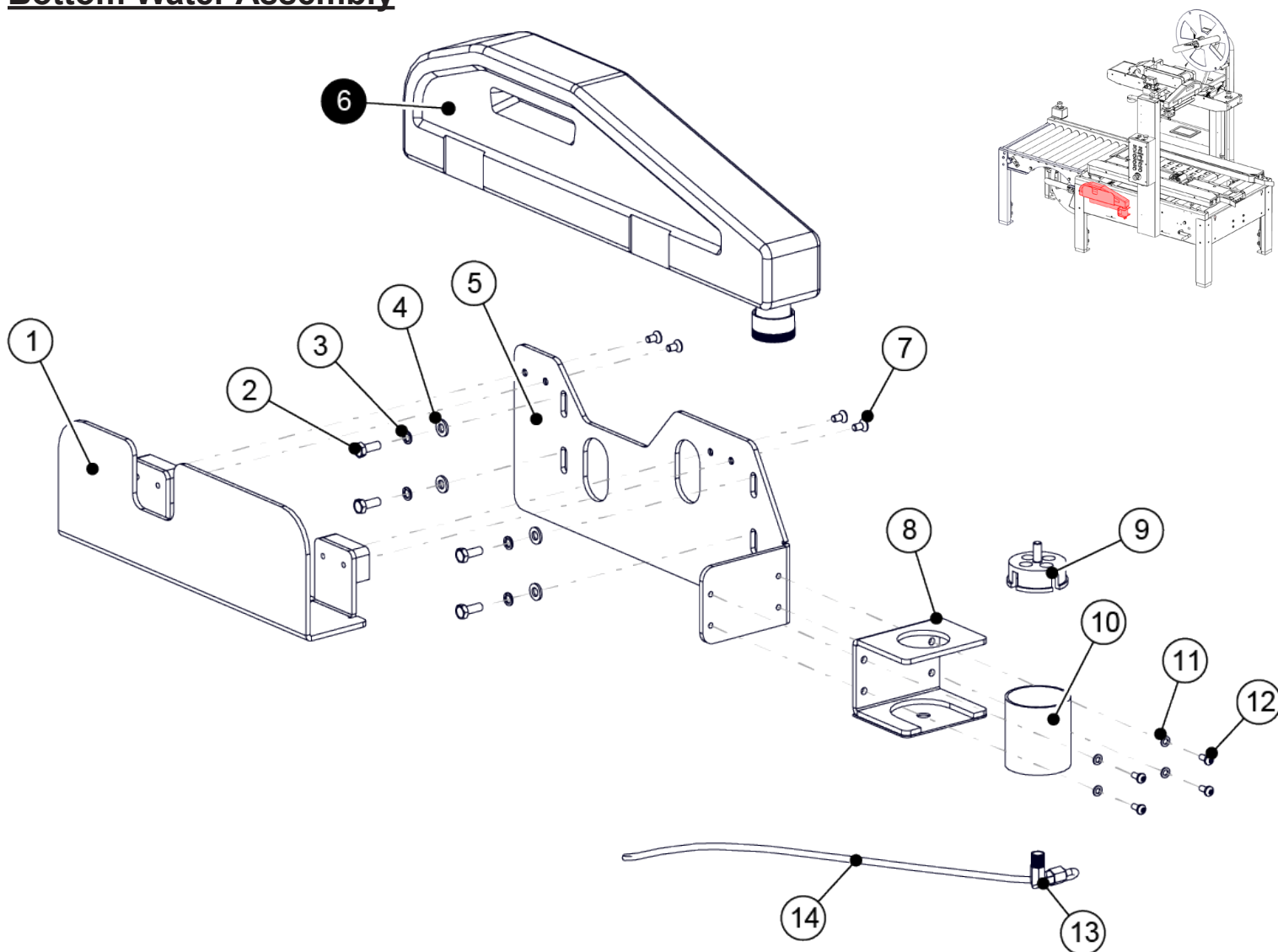

ITEM	PART NUMBER	DESCRIPTION	QTY
1	UPM4944	HOLDER BRACKET	1
2	UF3751	SS HHCS M6-1.0 x 16mm	4
3	UF6411	SS LW M6	4
4	UF6341	SS FW M6	4
5	UPM4943	FRAME	1
6	WST1014	WATER BOTTLE	1
7	UF3262	SS FHCS M5-0.8 x 10 mm	4
8	UPM4945	CUP HOLDER	1

ITEM	PART NUMBER	DESCRIPTION	QTY
9	UPM5901	PLUNGER	1
10	UPM4946	RESERVOIR CUP	1
11	UF6339	SS FW M4	4
12	UF6364	SS BHCS M4-0.7 x 10mm	8
13	UPM5543	ELBOW FITTING	1
14	UPM5542	LOWER WATER TUBE	1

# APPENDIX B

## Machine Frame Assembly

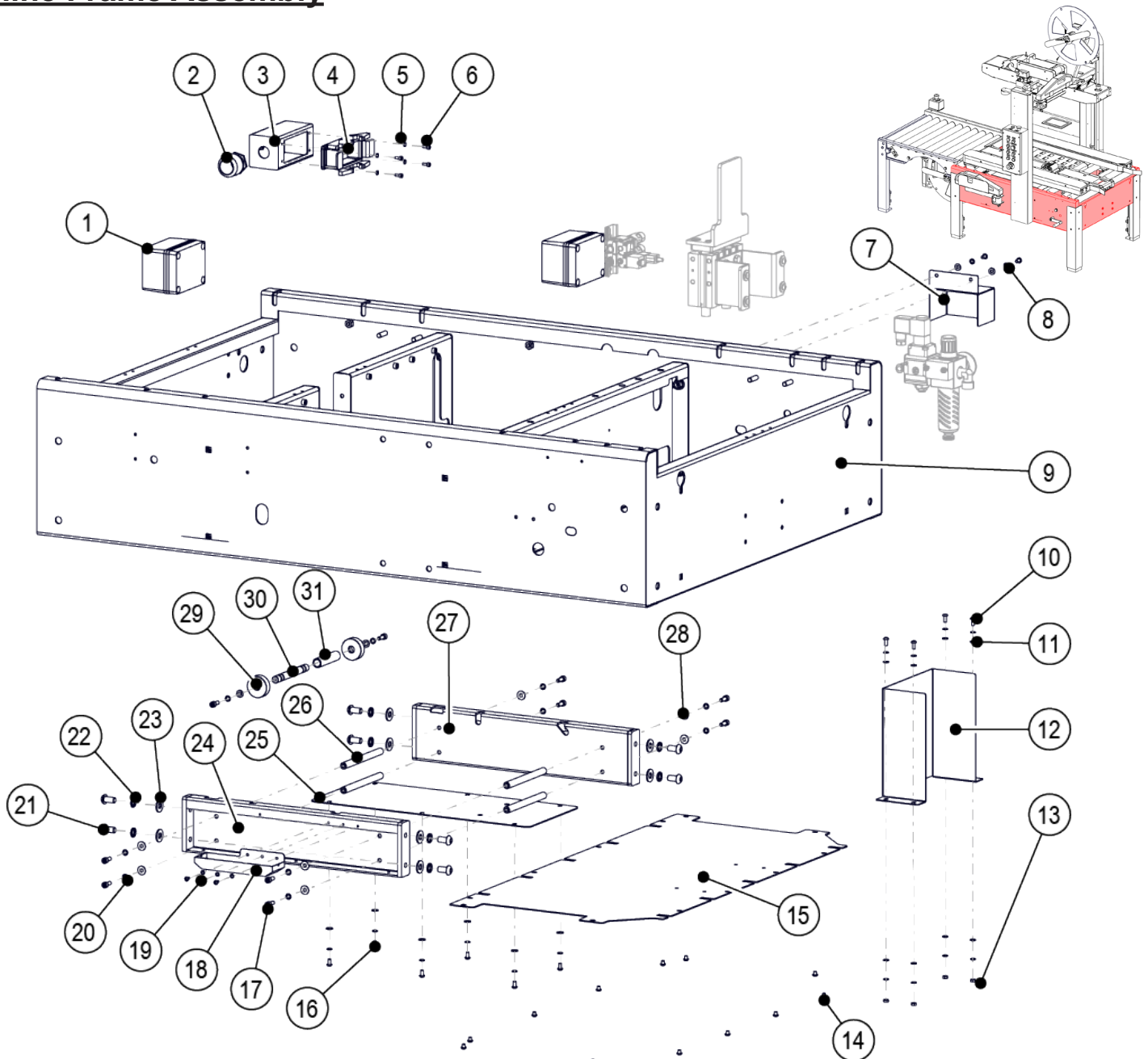

ITEM	PART NUMBER	DESCRIPTION	QTY
1	UPM6267	WIRING BOX	2
2	WET0241	CORD GRIP	1
3	UPM4929	ELECTRICAL RECEPTACLE BASE	1
4	UPM4938	RECEPTACLE CONNECTION	1
5	UF3681	LW M4	7
6	UF3759	SHCS M4-0.7 x 10mm	4
7	UPM5975	COIL CONNECTOR COVER	1
8	UF7021	M5 LW	15
9	UPM5940	BASE WELDMENT	1
10	UF3687	BHCS M5-0.8 x 12mm	4
11	UF1827	M5 FW	16
12	UPM5949	CYLINDER COVER	1
13	UF6307	M5 HEX NUT	4
14	UF5601	BHCS M5-0.8 x 6mm	12
15	UPM5948	FLOOR PLATE	1
16	UF3686	BHCS M5-0.8 x 10mm	8

ITEM	PART NUMBER	DESCRIPTION	QTY
17	UF3187	SHCS M6-1.0 x 16mm	10
18	UPM6253	LOWER DRAIN TRAY	1
19	UF7009	BHCS M4-0.7 x 8mm	3
20	UF6363	M6 LW	10
21	UF4252	BHCS M10-1.5 x 20mm	8
22	UF3743	M10 LW	8
23	UF3680	M10 FW	8
24	UPM6147	LOWER HOST BASE, L.H.	1
25	UPM5970	LOWER HOST COVER	1
26	UPM6252	SHAFT, 140L	4
27	UPM6148	LOWER HOST BASE, R.H.	1
28	UF1828	M6 FW	10
29	UPM5967	GUIDE ROLLER, 40OD	2
30	UPM6228	SHAFT, L115, GROOVED	1
31	UPM5966	ROLLER, dia 17, 72L, BLACK	1

# APPENDIX B

## Main Leg Assemblies

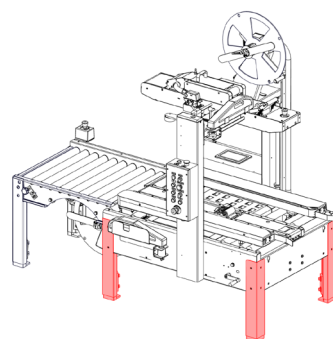
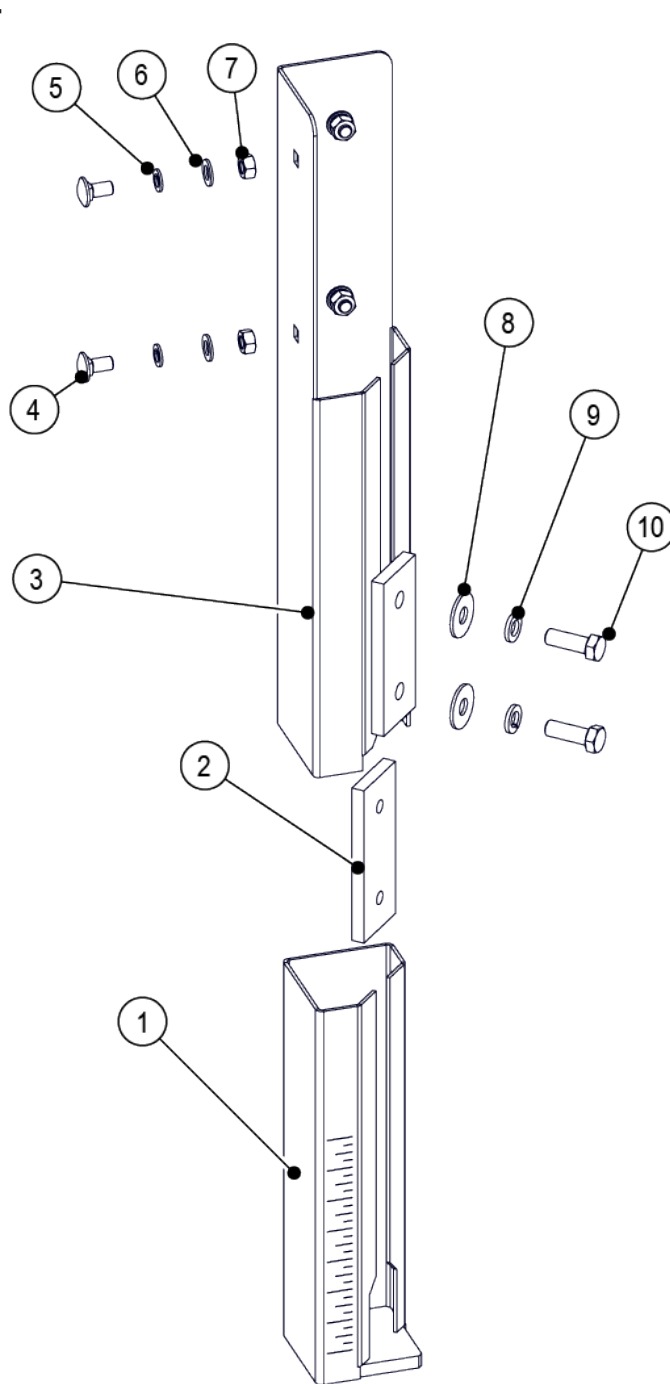

ITEM	PART NUMBER	DESCRIPTION	QTY
1	UMP7641	M1273 item 1	1
2	UPM7642	M1274	1
3	UPM7640	M1272 item 1	1
4	UF4229	M10-1.5 x 20-CARRIAGE BOLT	4
5	UF6371	M10 LW	4
6	UF3680	M10 FW	4

ITEM	PART NUMBER	DESCRIPTION	QTY
7	UF6314	M10-1.5 HNR	4
8	UF4231	M12 FW	2
9	UF4230	M12 LW	2
10	UF6393	M12-1.75 x 35 HHCS	2

# APPENDIX B

## Pneumatic Assemblies

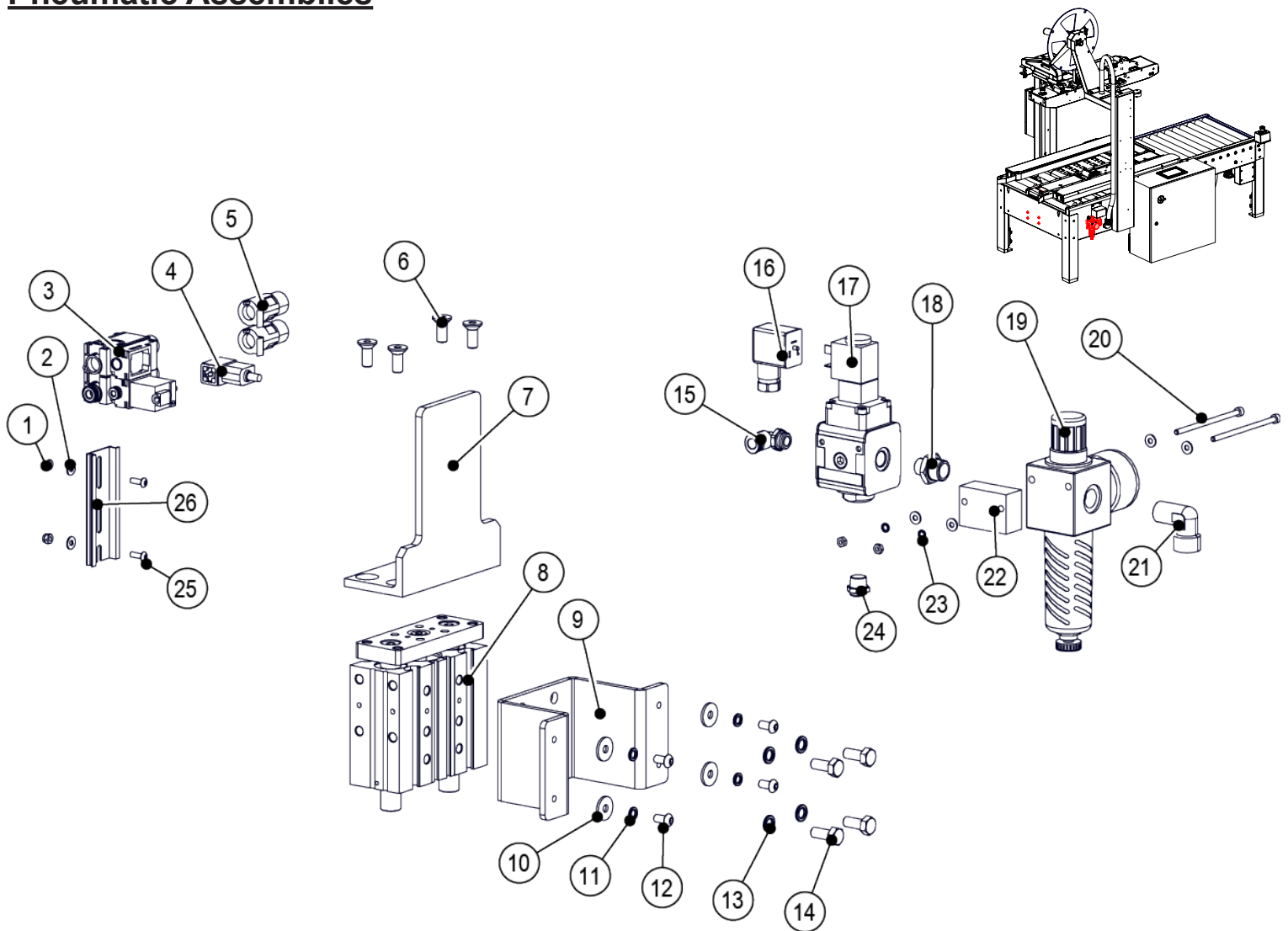

ITEM	PART NUMBER	DESCRIPTION	QTY
1	UF6376	M4 LOCK NUT	4
2	UF3710	M4 FW	6
3	UPM5980	SOLENOID VALVE	1
4	UPM5981	WIRE CONNECTOR	1
5	UPM3391	SILENCER VALVE	2
6	UF3264	FHCS M8-1.25 x 20mm	4
7	UPM7513	GATE FOR GUIDED CYL	1
8	UPM5972	CYLINDER W/ GUIDE ROD	1
9	UPM5971	STOP BRACKET	1
10	UF0103	M6 FW	4
11	UF6363	M6 LW	4
12	UF5600	BHCS M6-1.0 x 12mm	4
13	UF3640	M8 LW	4
14	UF6309	HHCS M8-1.25 x 20mm	4

ITEM	PART NUMBER	DESCRIPTION	QTY
15	UPM5984	90° QUICK CONNECTOR	1
16	UPM5979	ELECTRIC CONNECTOR	1
17	UPM5978	ELECTRONIC DUMP VALVE	1
18	UPM5983	CONNECTOR, STRAIGHT	1
19	UPM5977	REGULATOR	1
20	UF3694	SHCS M4-0.7 x 80mm	2
21	UPM5982	90° ELBOW	1
22	UPM5976	SPACER	1
23	UF3749	M4 LW	2
24	UPM6171	SILENCER	1
25	UF3649	BHCS M4-0.7 x 12mm	2
26	UPM6172	DIN RAIL, 90L	1

# APPENDIX B

## Centering Assembly 1

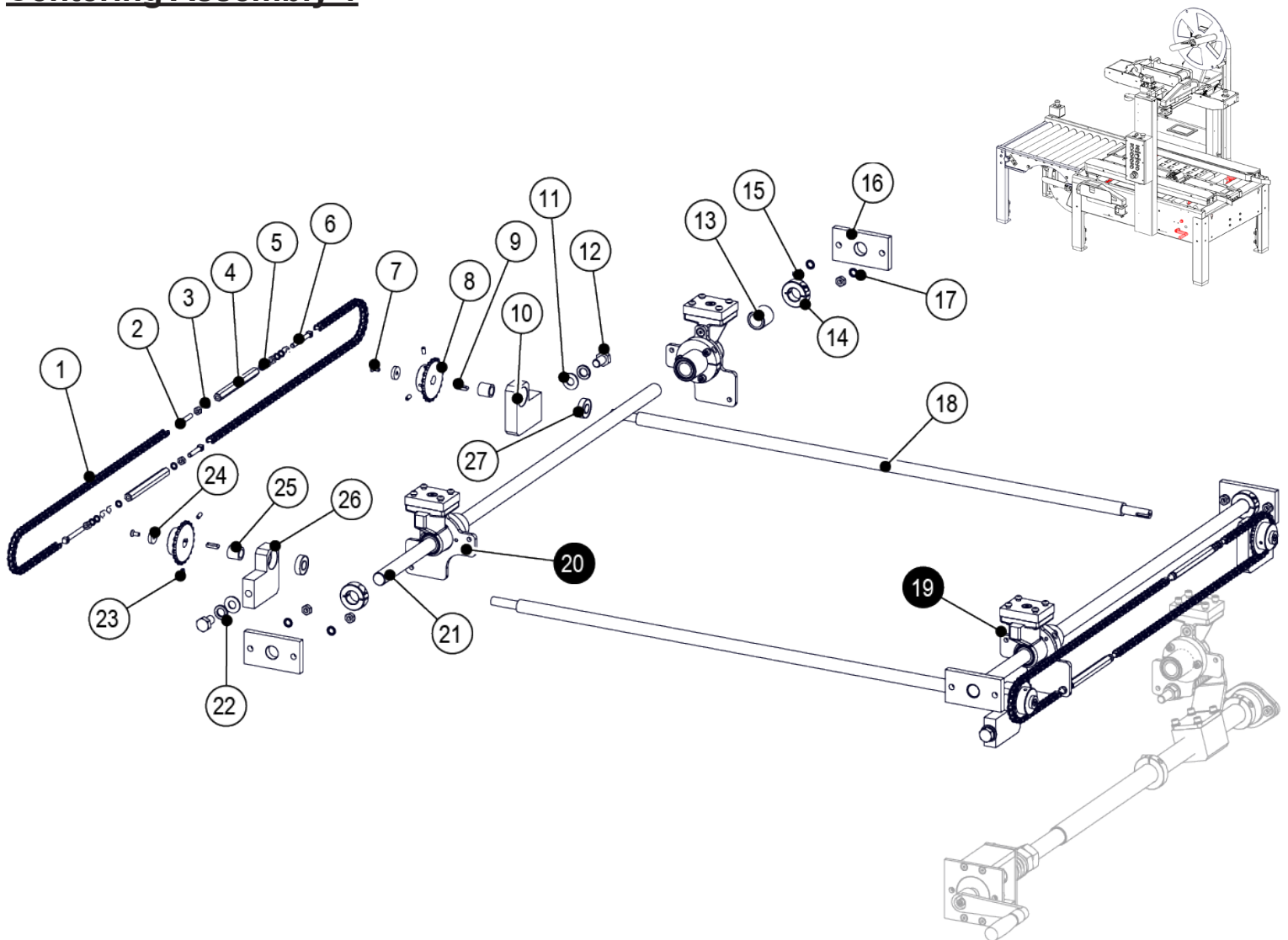

ITEM	PART NUMBER	DESCRIPTION	QTY
1	UPM6272	CHAIN #35	4
2	UPM1168	CHAIN THREADED LINK LH	4
3	UF6363	M6 LW	16
4	UPM3255	TURNBUCKLE	4
5	UF0062	M6 NUT	16
6	UPM3260	CHAIN THREADED LINK RH	4
7	UF5400	FHCS M5-0.8 x 12mm	4
8	UPM0028	SPROCKET	4
9	UPM5773	KEY 5x5-20	4
10	UPM3262	SPROCKET SHAFT BEARING HOUSING RH	2
11	UF4231	M12 FW	4
12	UF0061	HHCS M12-1.75 x 20mm	4
13	UPM3303	LINEAR BEARING 20mm	6
14	UPM3330	COLLAR 20mm	4

ITEM	PART NUMBER	DESCRIPTION	QTY
15	UF6369	M8 NUT	6
16	UPM6079	SHAFT ANCHOR PLATE	4
17	UF3640	M8 LW	6
18	UPM6269	SHAFT 888.6mm	2
19	UAM0141	DRIVE SUPPORT	1
20	UAM0516	DRIVE SUPPORT	2
21	UPM3316	SHAFT 20MM	2
22	UF4230	M12 LW	4
23	UF5925	SSS M5-0.8 x 10mm	8
24	UPM0150	SPROCKET SHAFT WASHER	4
25	UPM1646	SPROCKET SHAFT SPACER	4
26	UPM3275	SPROCKET SHAFT BEARING HOUSING LH	2
27	UPM1637	BEARING R8-2RS	4

# APPENDIX B

## Centering Assembly 2

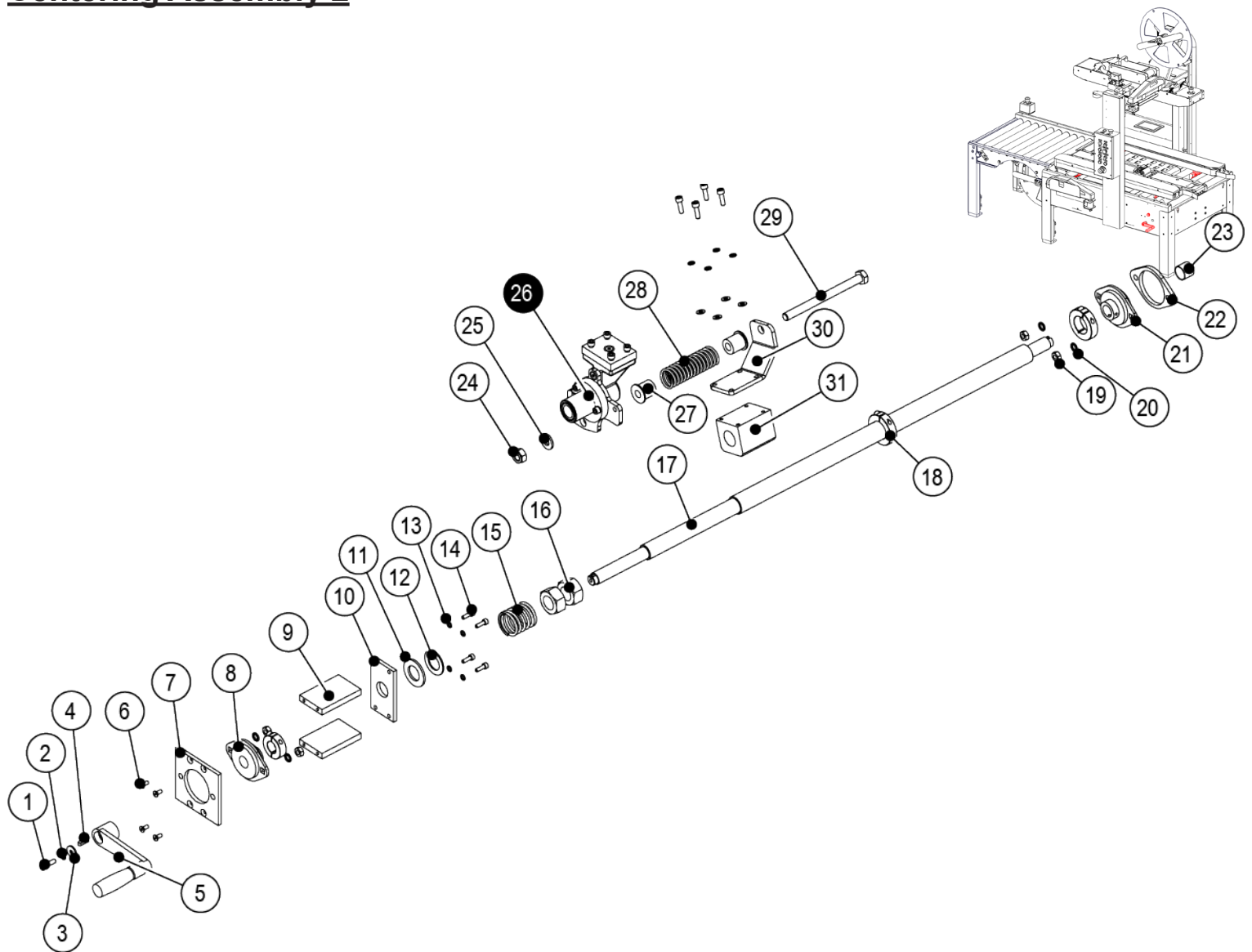

ITEM	PART NUMBER	DESCRIPTION	QTY
1	UF3179	SHCS M6-1.0 x 20mm	5
2	UF6363	M6 LW	5
3	UF0103	M6 FW	5
4	UPM5773	KEY 5x5-20	1
5	UPE0001	HANDLE, FOLDABLE	1
6	UF5400	FHCS M5-0.8 x 12mm	4
7	UPM6157	BEARING SPACER	1
8	UPM0523	FLANGE BEARING	1
9	UPM6159	STANDOFF	2
10	UPM6160	SPRING PLATE	1
11	UPM6161	FIBER WASHER	1
12	UF0053	M24 FW	1
13	UF7021	M5 LW	4
14	UF3169	SHCS M5-0.8 x 16mm	4
15	UPM0054	SPRING	1
16	UF3816	M24 NUT	2

ITEM	PART NUMBER	DESCRIPTION	QTY
17	UPM6152	ADJUSTMENT SHAFT	1
18	UPM6156	SHAFT COLLAR	3
19	UF6369	M8 NUT	4
20	UF3640	M8 LW	4
21	UPM0523	FLANGE BEARING	1
22	UPM6268	BRING SPCR	1
23	UPM6270	CAP	1
24	M12-1.75	M12 NUT	1
25	UPM6158	SEAL	1
26	UAM0509	DRIVE SUPPORT	1
27	UPM6154	SPRING SHAFT	2
28	UPM6155	SPRING	1
29	UF0114	HHCS M12-1.75 x 150mm	1
30	UPM6153	BRACKET	1
31	UPM6272	GUIDE BLOCK	1

# APPENDIX B

## Bridge Conduit

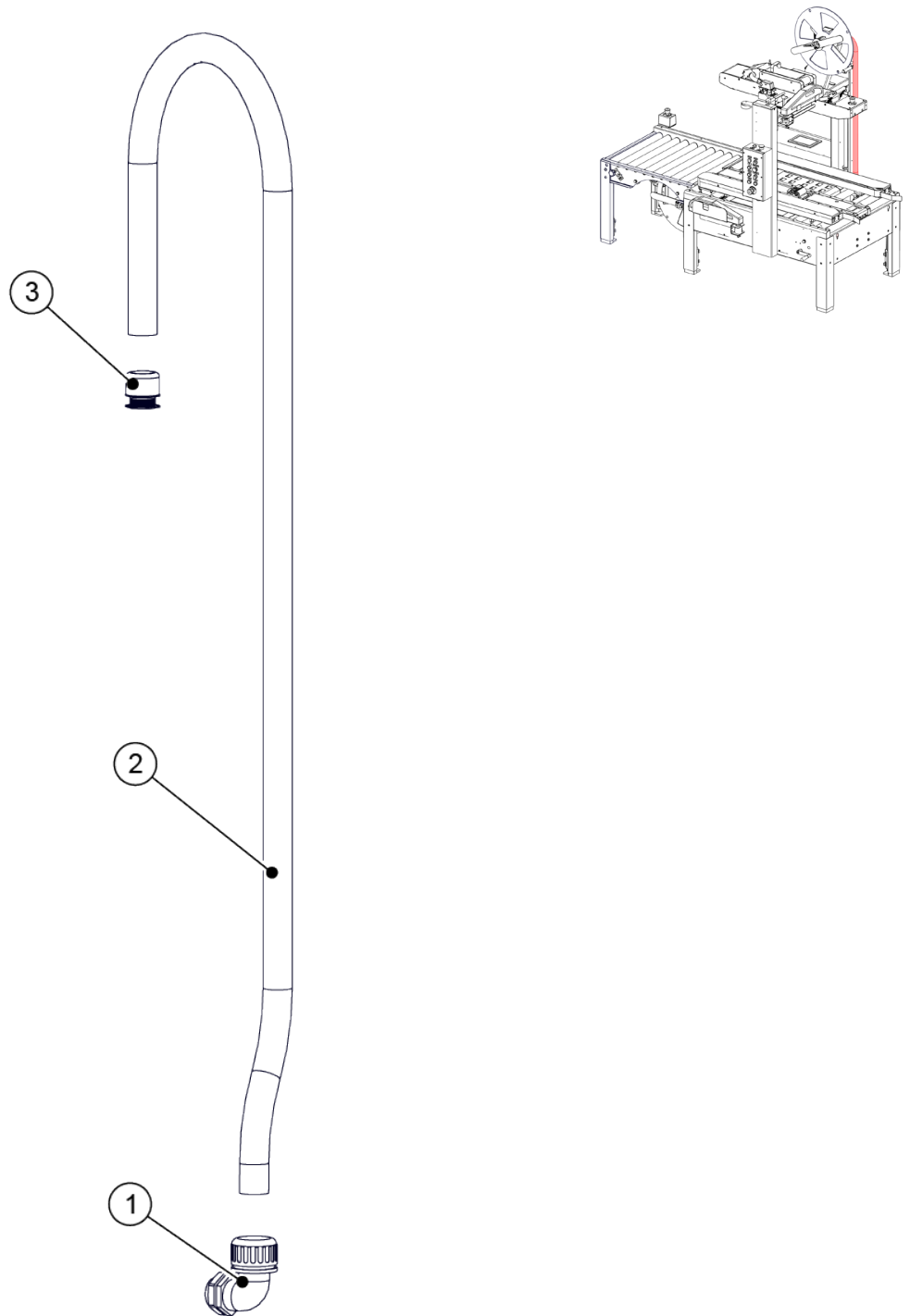

ITEM	PART NUMBER	DESCRIPTION	QTY
1	UPM4987	CORD SLEEVE ELBOW	1
2	UPM5119	CORD SLEEVE	1

ITEM	PART NUMBER	DESCRIPTION	QTY
3	UPM5078	CORD GRIP	1

# APPENDIX B

## Exit Plate

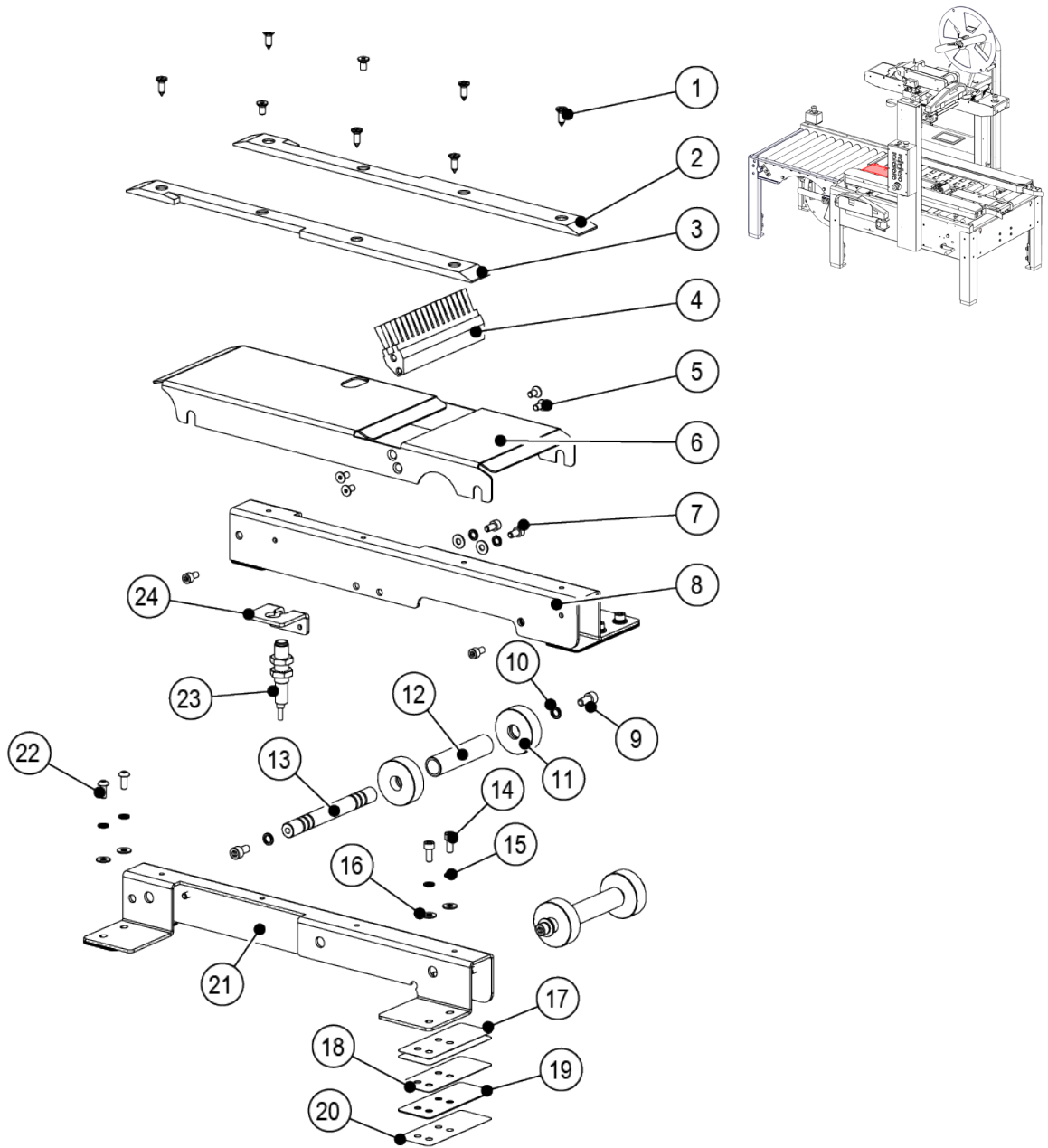

ITEM	PART NUMBER	DESCRIPTION	QTY
1	UF0075	M5-0.8-SELF TAPPING	8
2	UPM5962	SLIP PAD, R.H.	1
3	UPM5961	SLIP PAD, L.H.	1
4	UPY0023	BRUSH	1
5	UF6305	FHCS M5-0.8 x 10mm	4
6	UPM5964	COVER	1
7	UF0039	SHCS M5-0.8 x 10mm	6
8	UPM5960	REAR SUPPORT SEAT, R.H.	1
9	UF0038	SHCS M6-1.0 x 12mm	4
10	UF6363	M6 LW	4
11	UPM4934	GUIDE ROLLER, 400D	4
12	UPM4933	ROLLER, dia 17, 72L, BLACK	2
13	UPM6228	SHAFT, 115L, GROOVED	2

ITEM	PART NUMBER	DESCRIPTION	QTY
14	UF7003	SHCS M5-0.8 x 12mm	4
15	UF7021	M5 LW	10
16	UF1827	M5 FW	10
17	UPM6255	SHIM 0.2mm*	8
18	UPM6265	SHIM 0.5mm*	4
19	UPM5953	SHIM 1.0mm*	4
20	UPM6254	SHIM 0.1mm*	4
21	UPM5959	REAR SUPPORT SEAT, L.H.	1
22	UF3687	BHCS M5-0.8 x 12mm	4
23	UPM5969	PHOTOELECTRIC SENSOR	1
24	UPM5963	SENSOR BRACKET	1



# APPENDIX B

## Cover Plates

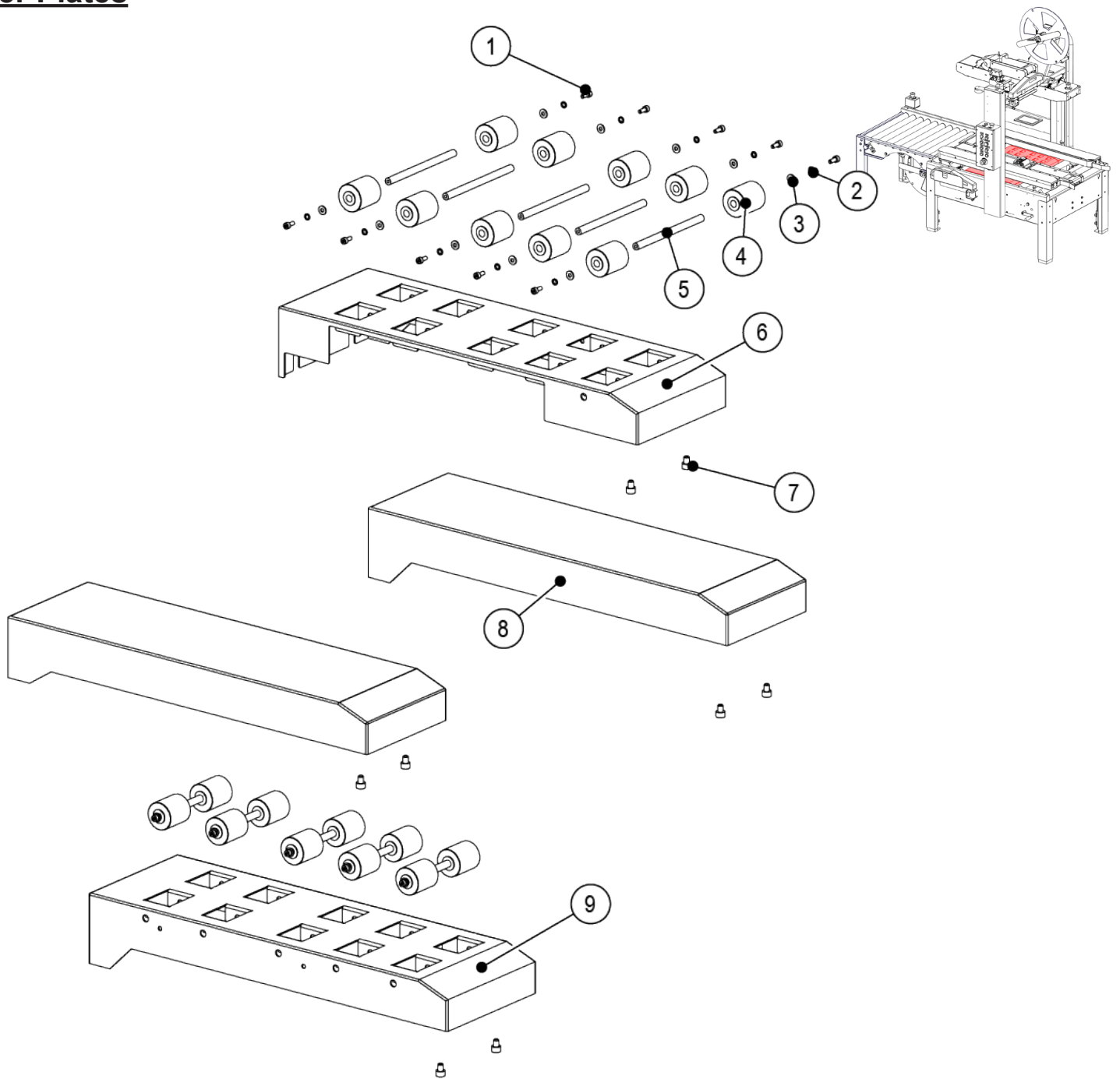

ITEM	PART NUMBER	DESCRIPTION	QTY
1	UF9148	SHCS M4-0.7 x 10mm	20
2	UF3749	M4 LW	20
3	UF3710	M4 FW	20
4	UPM4941	ROLLER	20
5	UPM4942	ROLLER SHAFT	10

ITEM	PART NUMBER	DESCRIPTION	QTY
6	UPM5958	ROLLER PLATE RH	1
7	UF3170	SHCS M6-1.0 x 8mm	8
8	UPM4930	SIDE COVER,	2
9	UPM5957	ROLLER PLATE LH	1

# APPENDIX B

## Entry Plate

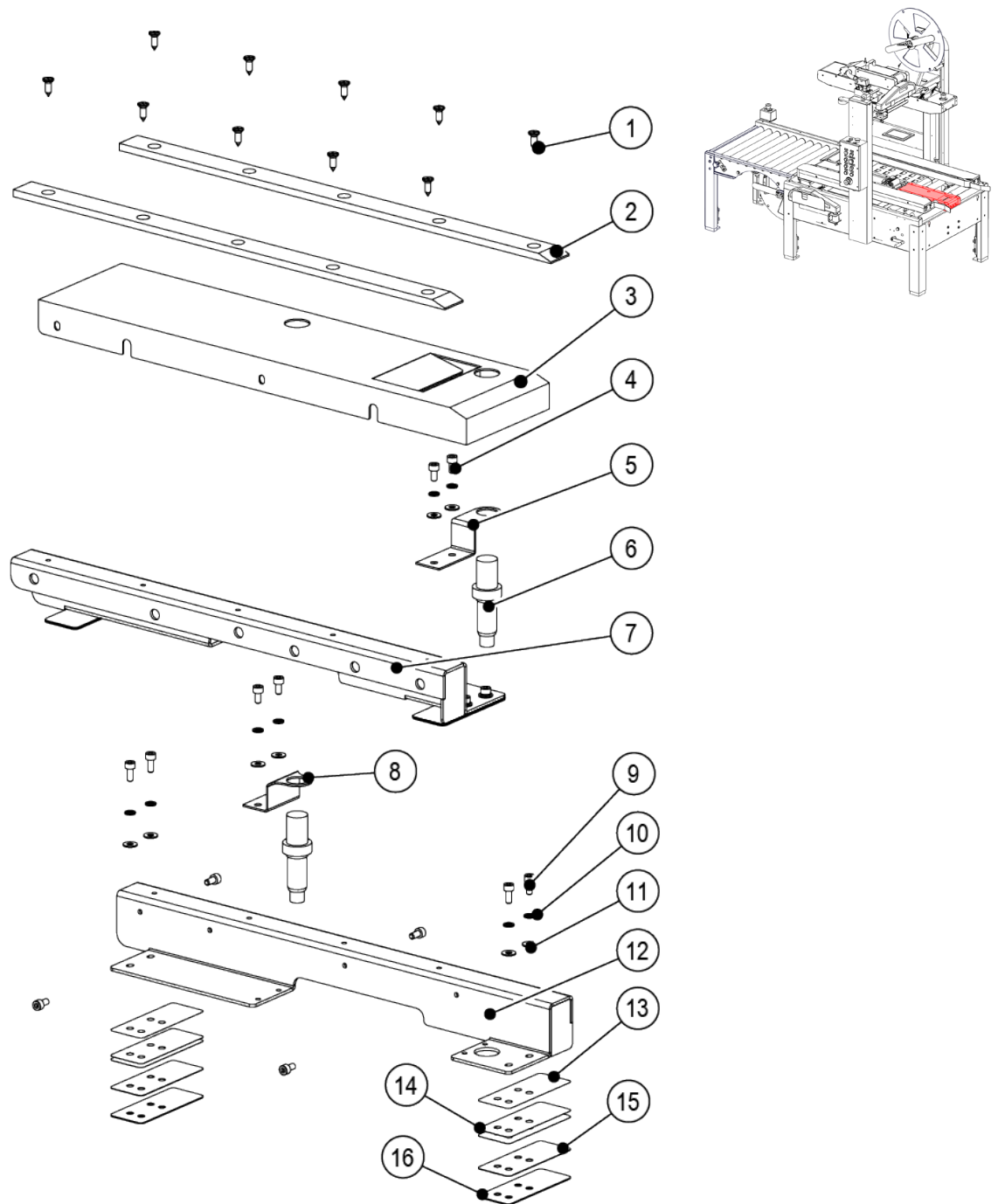

ITEM	PART NUMBER	DESCRIPTION	QTY
1	UF0075	M5-0.8-SELF TAPPING	10
2	UPM4954	SLIDING PAD	2
3	UPM5954	COVER PLATE	1
4	UF0039	SHCS M5-0.8 x 10mm	8
5	UPM5955	SENSOR SUPPORT	1
6	UPM0317	SENSOR	2
7	UPM5951	FRONT SEAT, L.H.	1
8	UPM5956	SENSOR SUPPORT	1
9	UF7003	SHCS M5-0.8 x 12mm	8

ITEM	PART NUMBER	DESCRIPTION	QTY
10	UF7021	M5 LW	12
11	UF1827	M5 FW	12
12	UPM5952	FRONT SEAT, R.H.	1
13	UPM6254	SHIM 0.1mm*	4
14	UPM6255	SHIM 0.2mm*	8
15	UPM6265	SHIM 0.5mm*	4
16	UPM5953	SHIM 1.0mm*	4

# APPENDIX B

## Rollers

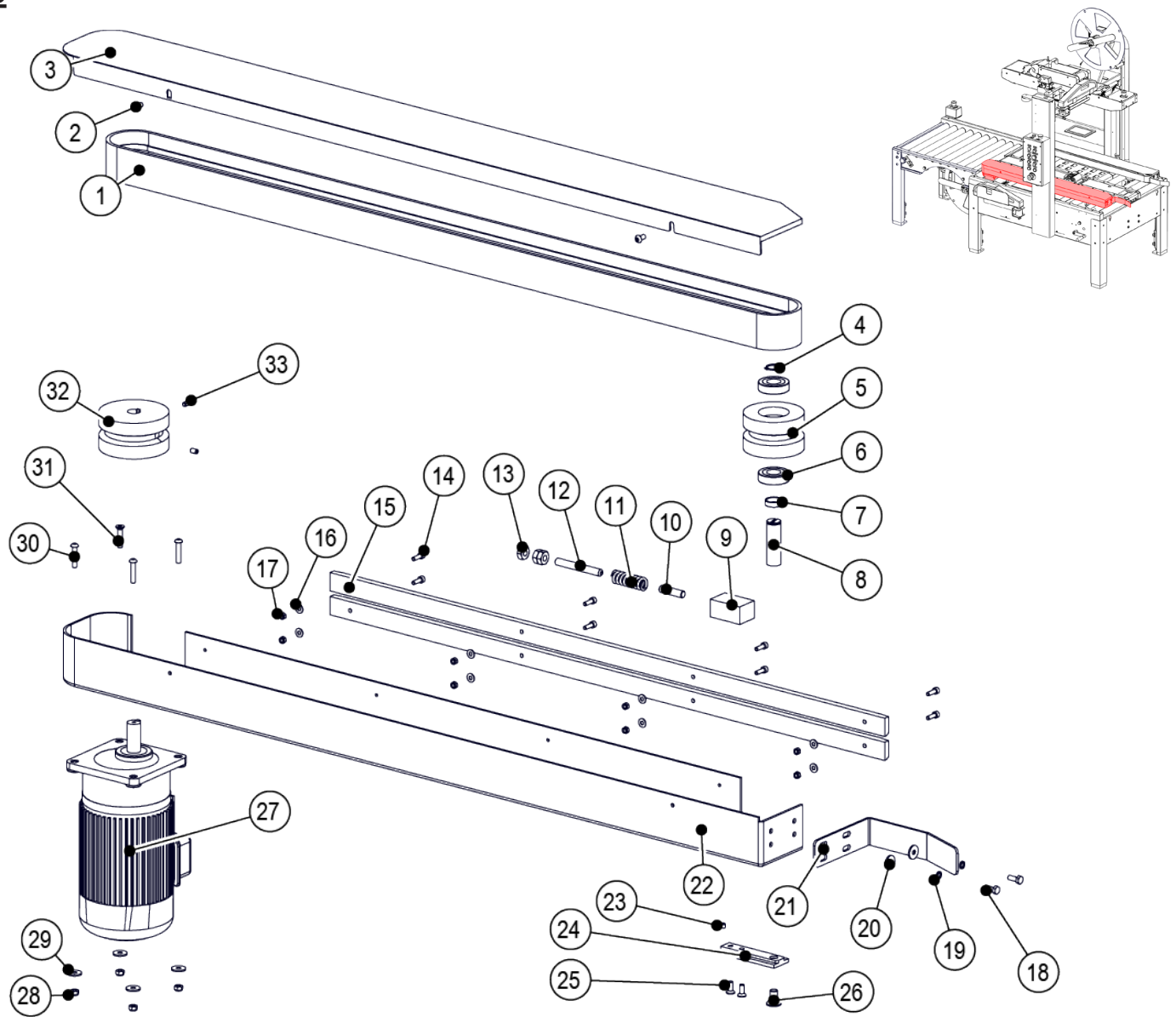

ITEM	PART NUMBER	DESCRIPTION	QTY
1	UPM4884	DRIVING BELT 50 x 2360L	1
2	UF5600	BHCS M6-1.0 x 12mm	2
3	UPM4975	COVER LEFT SIDE	1
4	UF0017	Ø12MM SNAP RING	1
5	UPM4885	IDLER PULLEY	1
6	UPM0324	BEARING PULLEY	2
7	UPM0109	IDLER PULLEY SPACER	1
8	UPM1233EV	IDLER PULLEY SHAFT	1
9	UPM0101	TENSIONER BACKING PLATE	1
10	UPM0112	SPRING LOCATOR PIN	1
11	UPM0038	DIE SPRING	1
12	UF1400	SSS HK 3/8-16 X 3"	1
13	UF3377	3/8"-16-HNR	3
14	UF3169	SHCS M5-0.8 x 16mm	8
15	UPM4974	BELT PAD	2
16	UF1827	M5 FW	8
17	UF3393	M5 LOCK-NUT	8

ITEM	PART NUMBER	DESCRIPTION	QTY
18	UF0454	HHCS M6-1.0 x 16mm	2
19	UF6363	M6 LW	2
20	UF0103	M6 FW	2
21	UPM0647	CARTON RETAINER	1
22	UPM6163	DRIVE WELDMENT, L.H.	1
23	UF1411	SSS M6-1.0 x 6mm	1
24	UPM2156	TENSIONER ALIGNMENT PLATE	1
25	UF1192	FHCS M6-1.0 16mm	2
26	UF3748	FHCS M10-1.5 x 20mm	1
27	UPM3327	MOTOR 1/3HP 25:1	1
28	UF5900	M6 LOCK-NUT	4
29	UF0103	M6 FW	4
30	UF3752	BHCS M6-1.0 x 30mm	3
31	UF3712	FHCS M6-1.0 x 30mm	1
32	UPM4883	DRIVE PULLEY	1
33	UF3683	SSS M6-1.0 10mm	2

# APPENDIX B

## Base Assembly

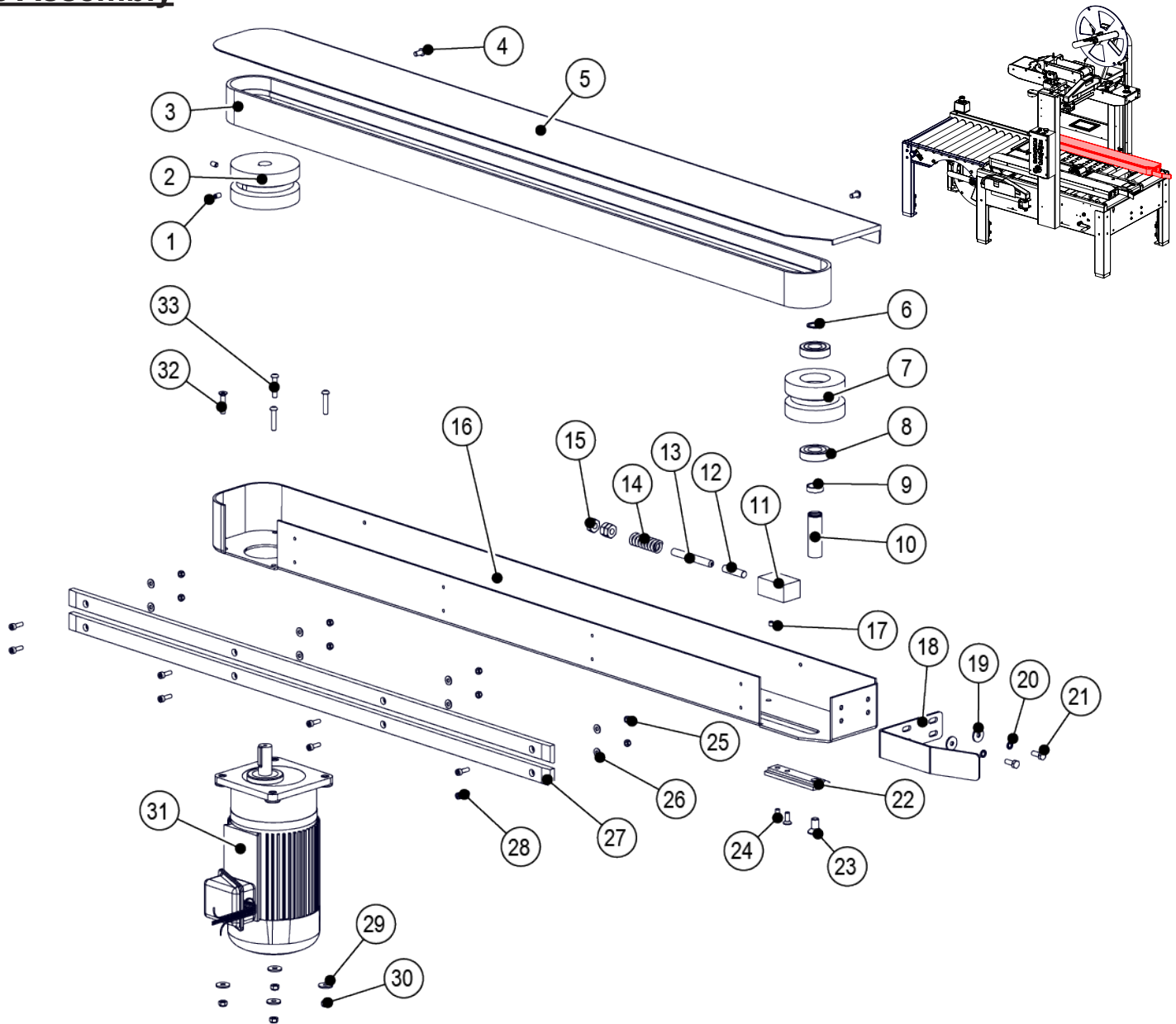

ITEM	PART NUMBER	DESCRIPTION	QTY
1	UF3683	SSS M6-1.0 x 10mm	2
2	UPM4883	DRIVE PULLEY	1
3	UPM4884	DRIVING BELT 50 x 2360L	1
4	UF5600	BHCS M6-1.0 x 12mm	2
5	UPM4973	COVER RIGHT SIDE	1
6	UF0017	Ø12MM SNAP RING	1
7	UPM4885	IDLER PULLEY	1
8	UPM0324	BEARING PULLEY	2
9	UPM0109	IDLER PULLEY SPACER	1
10	UPM1233EV	IDLER PULLEY SHAFT	1
11	UPM0101	TENSIONER BACKING PLATE	1
12	UPM0112	SPRING LOCATOR PIN	1
13	UF1400	SSS HK 3/8-16 X 3"	1
14	UPM0038	DIE SPRING	1
15	UF3377	3/8"-16-HNR	3
16	UPM6164	DRIVE WELDMENT, R.H	1
17	UF1411	SSS M6-1.0 x 6mm	1

ITEM	PART NUMBER	DESCRIPTION	QTY
18	UPM0647	CARTON RETAINER	1
19	UF0103	M6 FW	2
20	UF6363	M6 LW	2
21	UF0454	HHCS M6-1.0 x 16mm	2
22	UPM2156	TENSIONER ALIGNMENT PLATE	1
23	UF3748	FHCS M10-1.5 x 20mm	1
24	UF1192	FHCS M6-1.0 x 16mm	2
25	UF3393	M5 LOCK-NUT	8
26	UF1827	M5 FW	8
27	UPM4974	BELT PAD	2
28	UF3169	SHCS M5-0.8 x 16mm	8
29	UF0103	M6 FW	4
30	UF5900	M6 LOCK-NUT	4
31	UPM3327	MOTOR 1/3HP 25:1	1
32	UF3712	FHCS M6-1.0 x 30mm	1
33	UF3752	BHCS M6-1.0 x 30mm	3

# APPENDIX B

## Leg Assembly

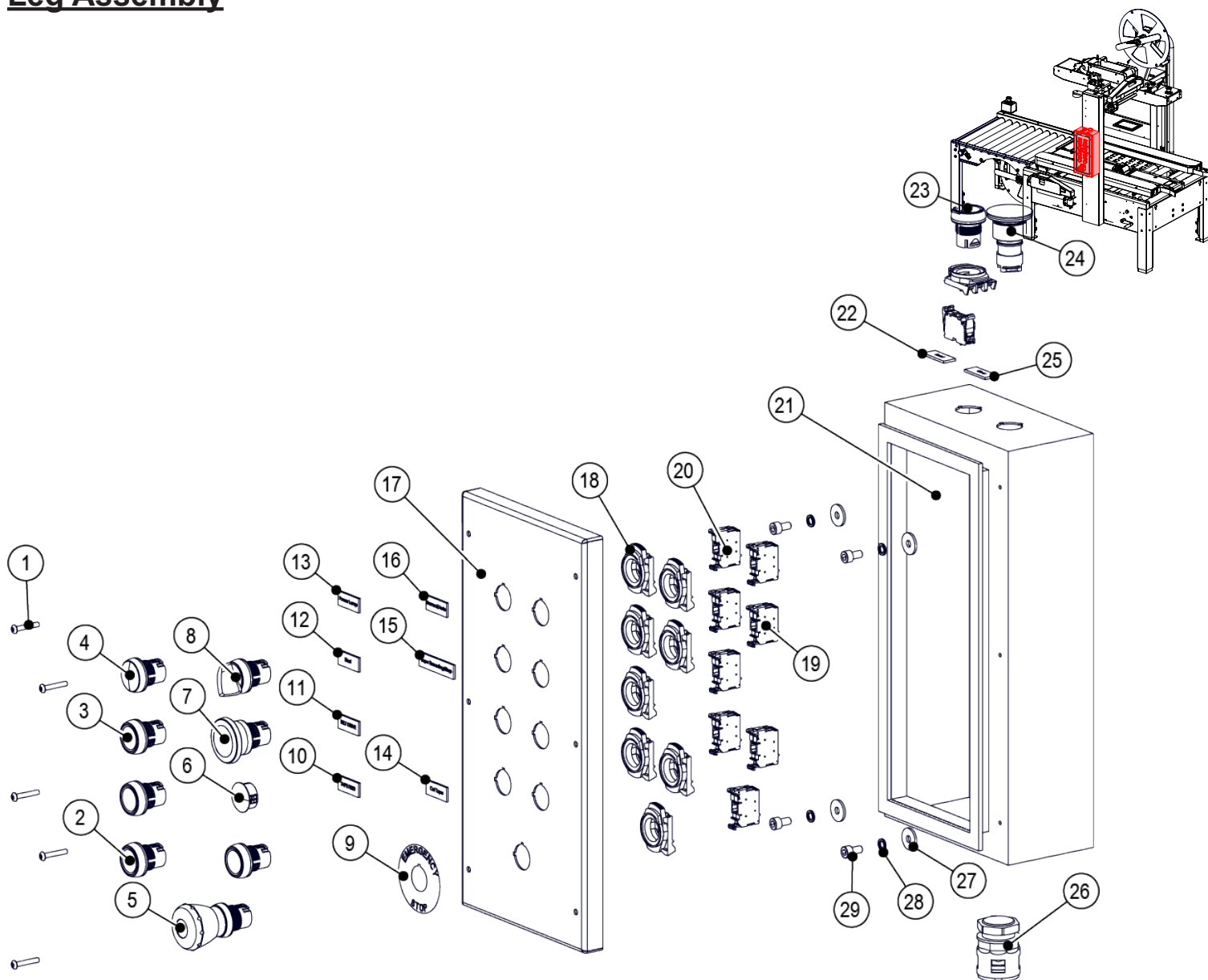

ITEM	PART NUMBER	DESCRIPTION	QTY
1	UF0069	BHCS M4-0.7 x 25mm	6
2	UPM5157	BUTTON, BLACK	3
3	UPM5155	BUTTON, GREEN	1
4	UPM5154	POWER LIGHT, WHITE	1
5	UPM3892	EMERGENCY STOP BUTTON	1
6	UPM4493	HOLE PLUG 22mm	1
7	UPM6051	BUTTON, RED MUSHROOM	1
8	UPM5159	SWITCH 2 POS	1
9	UPM6045	E-STOP LABEL	1
10	UPM4899	LEGEND PLATE "TAPE FEED"	1
11	UPM4897	LEGEND PLATE "BELT DRIVE"	1
12	UPM4895	LEGEND PLATE "START"	1
13	UPM4894	LEGEND PLATE "POWER LAMP"	1
14	UPM4900	LEGEND PLATE "CUT TAPE"	1
15	UPM4896	LEGEND PLATE "TAPE THREADING/STOP"	1

ITEM	PART NUMBER	DESCRIPTION	QTY
16	UPM4893	LEGEND PLATE "MANUAL/AUTO"	1
17	UPM6168	OPERATION BOX COVER	1
18	UPM7630	LATCH	9
19	UPM4720	NC CONTACT	2
20	UPM7631	NO CONTACT	7
21	UPM6169	OPERATION BOX	1
22	UPM4903	LEGEND PLATE "CLEAR"	1
23	UPM6047	BUTTON, BLUE ILLUMINATED	1
24	UPM4926	MUSHROOM, BLUE	1
25	UPM4903	LEGEND PLATE "CLEAR"	1
26	UPM4905	CORD GRIP	1
27	UF0103	M10-23-1.0	4
28	UF6363	M6 LW	4
29	UF0038	SHCS M6-1.0 x 12mm	4

# APPENDIX B

## Centering Assembly

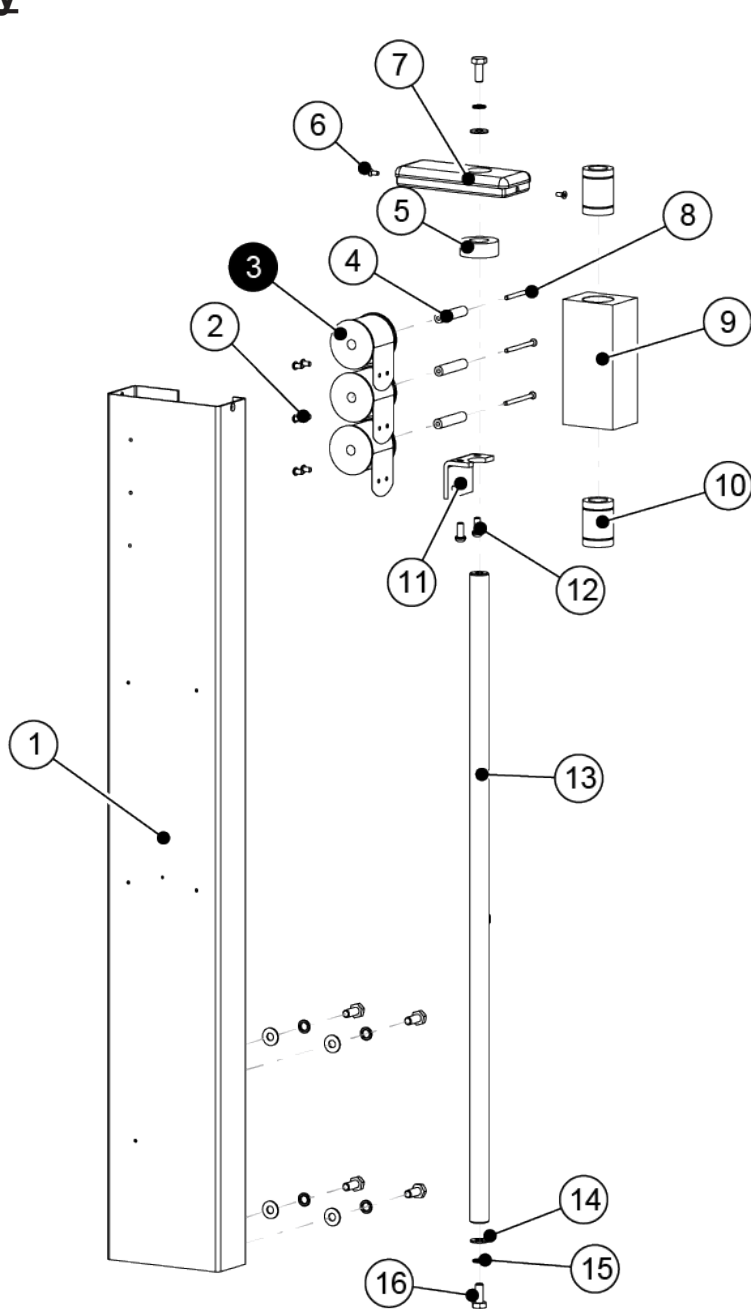

ITEM	PART NUMBER	DESCRIPTION	QTY
1	UPM5640	WAT CASE SEALER, EU	1
2	UF1211	BHCS M6-1.0×10mm	6
3	USM0893	CONSTANT FORCE SPRING	3
4	UPM0743	SPRING MANDREL SHAFT	3
5	UPM2251	SAFETY BUMPER	1
6	UF5400	FHCS M5-0.8×12mm	2
7	UPM0741EV	COLUMN CAP LH	1
8	UF0075	M5-0.8×68mm	3
9	UPM5991	COLUMN BLOCK	1

ITEM	PART NUMBER	DESCRIPTION	QTY
10	UPM4986	LINEAR BEARING 25 mm	2
11	UPM4150	SPRING ANCHOR	1
12	UF1318	BHCS M8-1.25×20mm	2
13	UPM0738	COLUMN SHAFT	1
14	UF3680	M10 FW	6
15	UF3743	M10 LW	6
16	UF3647	HHCS M10-1.25×25mm	6

# APPENDIX B

## Machine Frame

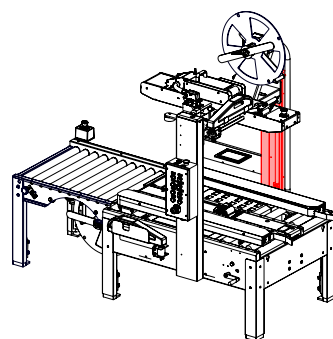
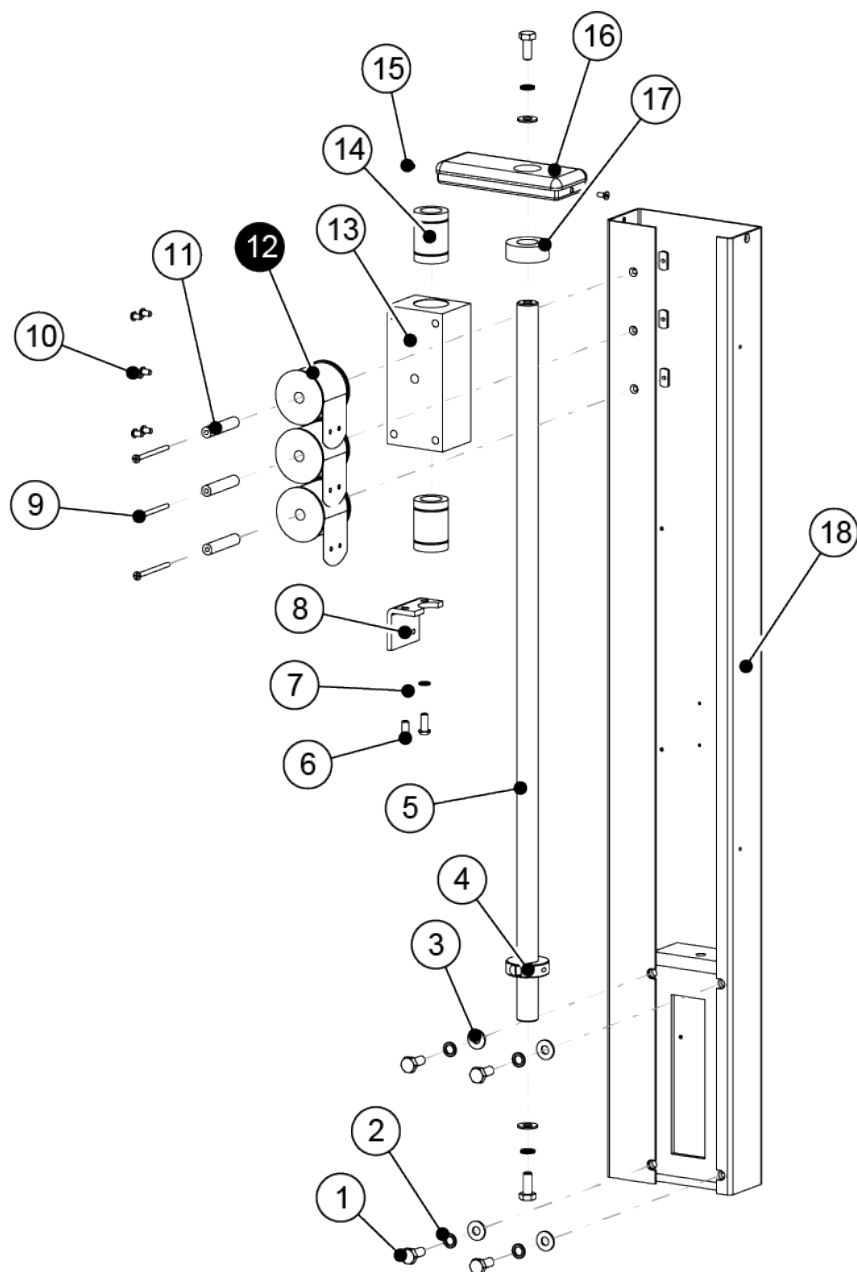

ITEM	PART NUMBER	DESCRIPTION	QTY
1	UF3647	HHCS M10-1.25 x 25mm	6
2	UF3743	M10 LW	6
3	UF3680	M10 FW	6
4	UPM9741	SHAFT COLLAR	1
5	UPM0738	COLUMN SHAFT	1
6	UF1318	BHCS M8-1.25 x 20mm	2
7	UF3640	M8 LW	2
8	UPM3740	SPRING ANCHOR RIGHT	1
9	UF0075	FHCS M5-0.8x68mm	3
10	UF1211	BHCS M6-1.0x10mm	6

ITEM	PART NUMBER	DESCRIPTION	QTY
11	UPM0743	SPRING MANDREL SHAFT	3
12	USM0893	CONSTANT FORCE SPRING	3
13	UPE0164	COLUMN BLOCK, RIGHT	1
14	UPM4986	LINEAR BEARING 25 mm	2
15	UF5400	FHCS M5-0.8x12mm	2
16	UPM2182	COLUMN CAP RH	1
17	UPM2251	SAFETY BUMPER	1
18	UPM6013	COLUMN WELDMENT, R.H.	1

# APPENDIX B

## Powered Exit Table

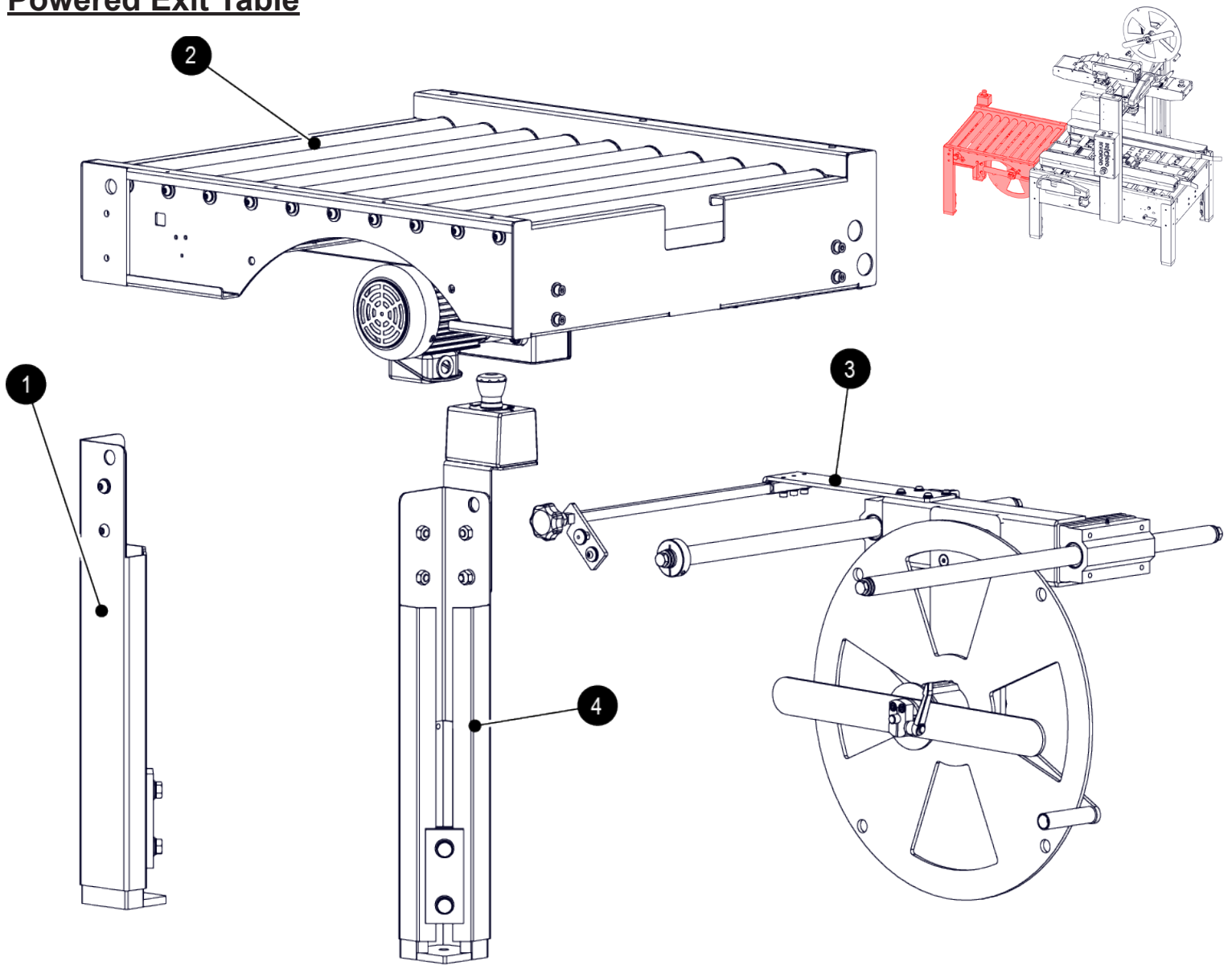

ITEM	PART NUMBER	DESCRIPTION	QTY
1	USM0910	OUTFEED LEG WELDMENT	1
2	USM0964	OUTPUT TABLE TOP	1
3	UAM0506	TAPE ROLL CARRIAGE	1
4	USM0963	OUTFEED LEG W/E-STOP	1



# APPENDIX B

## Exit Table Leg Without Emergency Stop

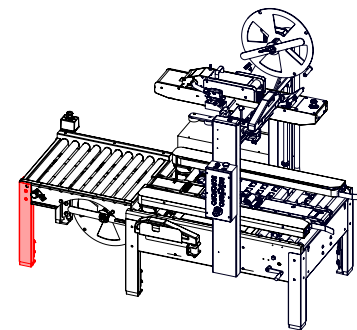
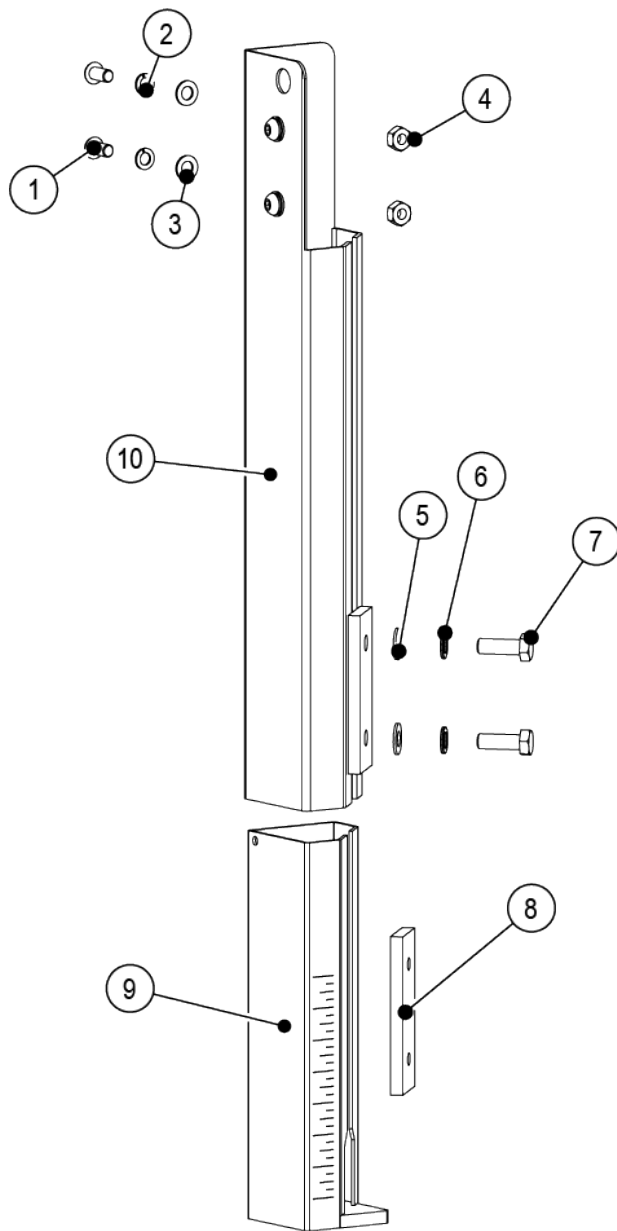

ITEM	PART NUMBER	DESCRIPTION	QTY
1	UF4252	BHCS M10-1.5 x 20mm	4
2	UF6371	LW M10	4
3	UF3680	FW M10	4
4	UF6314	HNR M10-1.5	4
5	UF4231	FW M12	2
6	UF4230	LW M12	2

ITEM	PART NUMBER	DESCRIPTION	QTY
7	UF6393	HHCS M12-1.75 x 35mm	2
8	UPM0931	LEG FRICTION PLATE	1
9	UPM0847	LEG ADJUSTMENT	1
10	UPM5142	LEG WELDMENT	1

# APPENDIX B

## Exit Table Leg With Emergency Stop

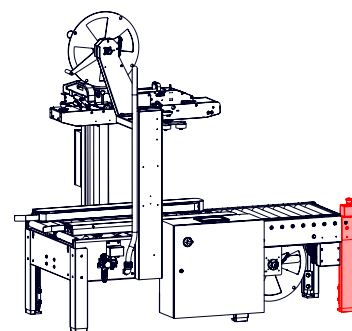
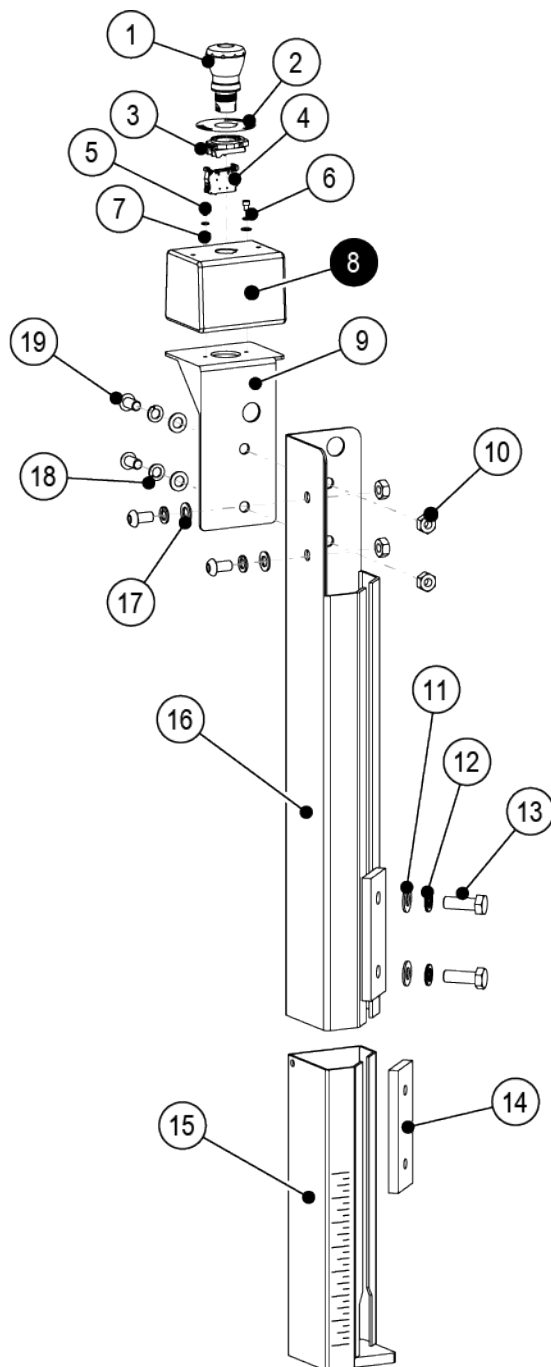

ITEM	PART NUMBER	DESCRIPTION	QTY
1	UPM3892	E-STOP BUTTON	1
2	UPM6045	E-STOP LABEL	1
3	UPM7630	LATCH	1
4	UPM4720	NC CONTACT	1
5	UF4312	SHCS M4-0.7 x 6mm	2
6	UF3749	M4 LW	2
7	UF3710	M4 FW	2
8	UPM6170	BUTTON BOX	1
9	UPM6044	E-STOP BRACKET	1
10	UF1540EV	M10 HEX NUT	4

ITEM	PART NUMBER	DESCRIPTION	QTY
11	UF4231	M12 FW	2
12	UF4230	M12 LW	2
13	UF3734	HHCS M12-1.75 x 35mm	2
14	UPM7642	LEG FRICTION PLATE	1
15	UPM7641	LEG ADJUSTMENT	1
16	UPM5141	LEG WELDMENT	1
17	UF3680	FW M10	4
18	UF6371	M10 LW	4
19	UF4252	BHCS M10-1.5 x 20mm	4

# APPENDIX B

## Exit Table Roller Assembly

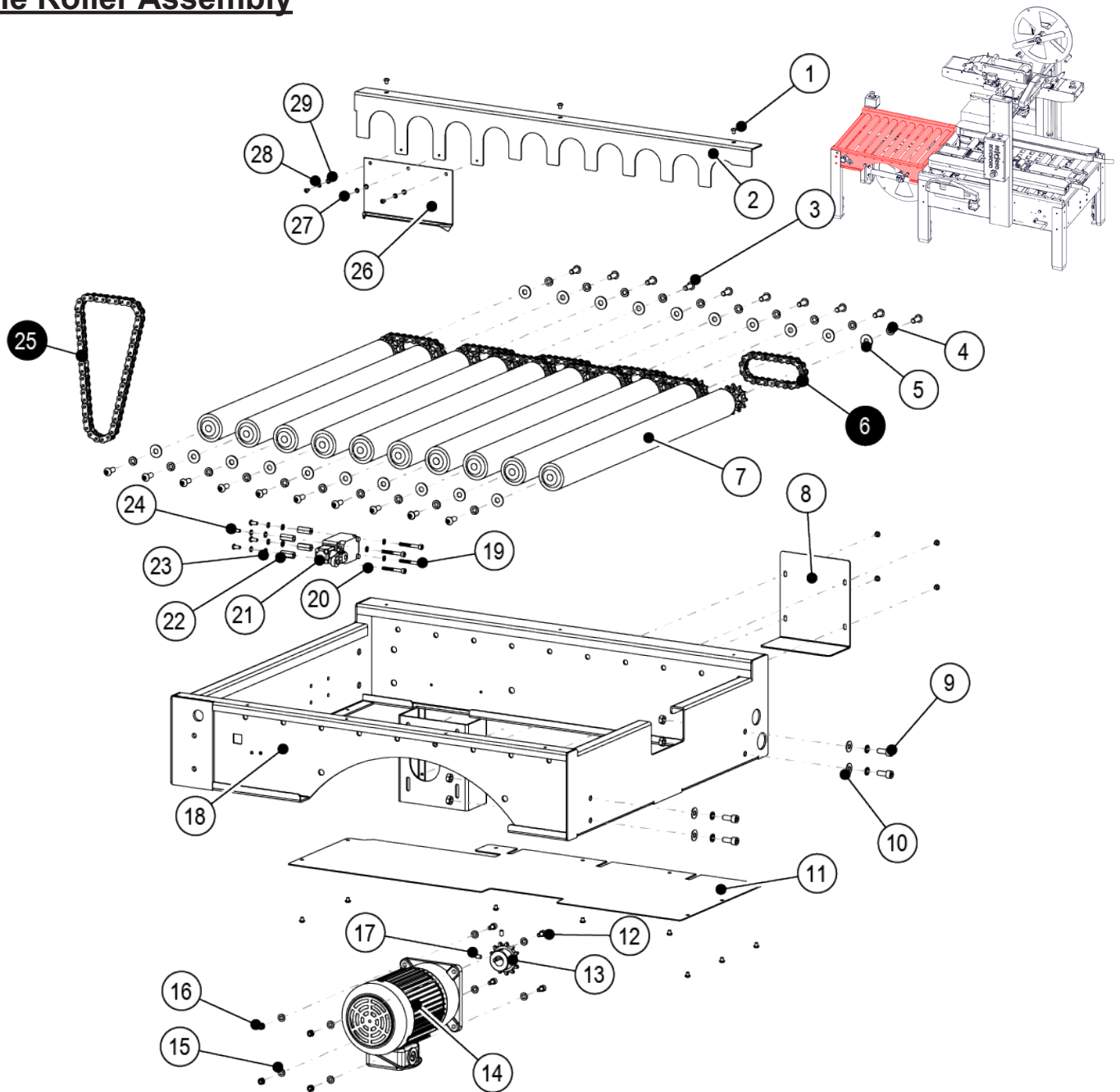

ITEM	PART NUMBER	DESCRIPTION	QTY
1	UF5601	M5-0.8-BHCS	15
2	UPM4969	CHAIN COVER	1
3	UF1318	BHCS M8-1.25 x 20mm	20
4	UF0867	M8 LW	24
5	UF1821	M8 FW	20
6	UPM4891	CHAIN #40, 12 PITCH	8
7	UPM5125	POWERED ROLLER	10
8	UPM5124	CHAIN COVER	1
9	UF0864	SHCS M8-1.25 x 20MM	4
10	UF0105	M8 FW	4
11	UPM6038	BOTTOM COVER	1
12	UF0038	SHCS M6-1.0 x 12mm	4
13	UPM5126	SPROCKET	1
14	UPM7874	MOTOR, 1/3 HP 15:1	1
15	UF6341	M6 FW	8

ITEM	PART NUMBER	DESCRIPTION	QTY
16	UF3391	LOCK NUT M6	4
17	UF3750	SSS M6 x 10mm	2
18	UAM0505	OUTPUT TABLE WELDMENT	1
19	UF3776	SHCS M5 x 0.8 x 35mm	4
20	UF7023	M5 LW	8
21	UPM5711	SWITCH SNAP ACTION SPDT	1
22	UPM6037	POST	4
23	UF6340	M5 W	4
24	UF3687	BHCS M5-0.8 x 12mm	4
25	UPM4890	CHAIN #40, 25 PITCH	1
26	UPM5222	CHAIN SHIELD	1
27	UF7009	BHCS M4-0.7 x 8mm	3
28	UF3681	M4 LW	3
29	UF3710	M4 FW	3

# APPENDIX B

## Bottom Tape Mandrel Assembly

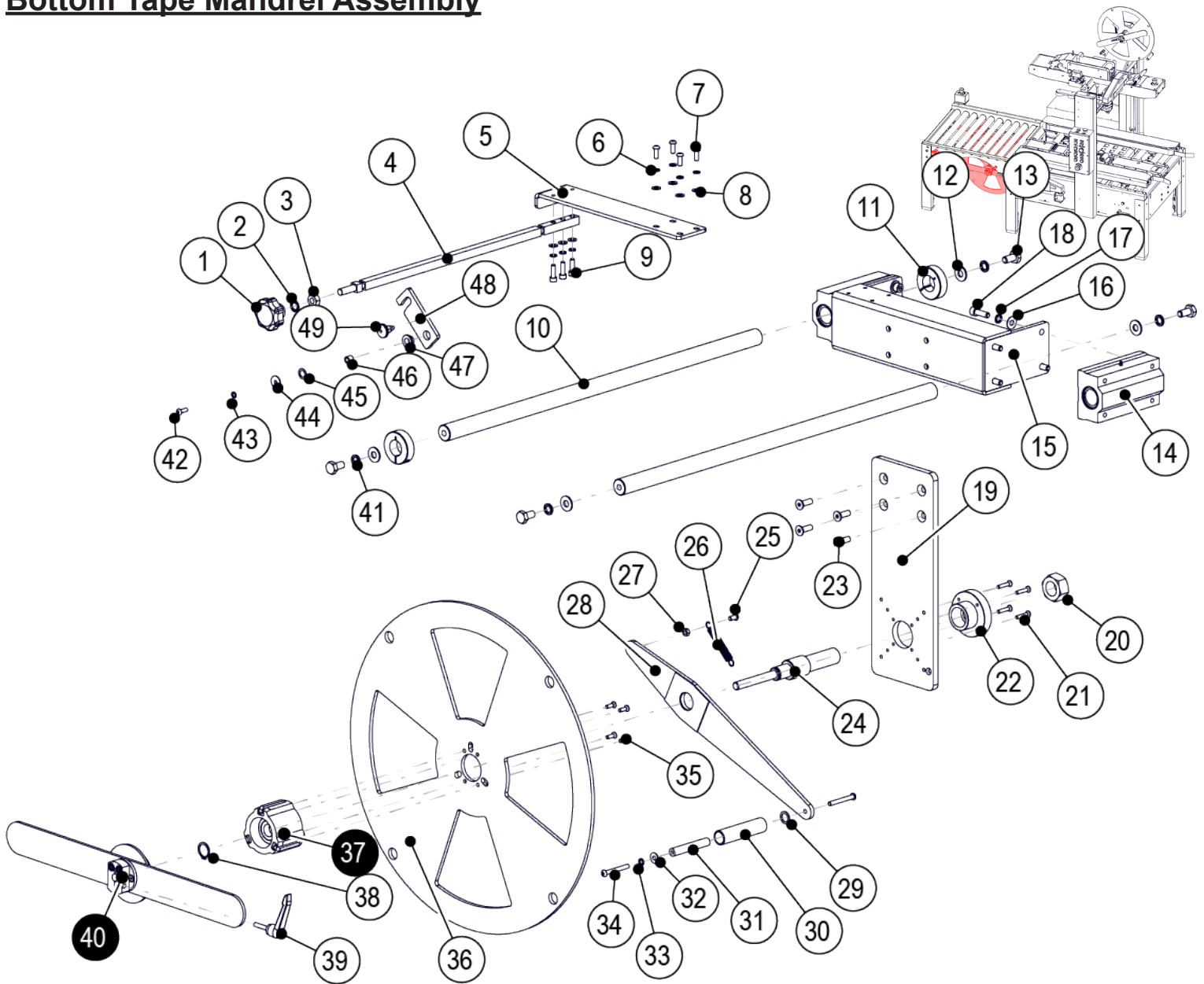

ITEM	PART NUMBER	DESCRIPTION	QTY
1	UPM2784	HANDLE	1
2	UF0057	INTERNAL TOOTH LW M10	1
3	UF0107	M10 JAM NUT	1
4	UPM6041	BAR	1
5	UPM6042	BRACKET	1
6	UF6363	M6 LW	7
7	UF1250EV	BHCS M6-1.0 x 16mm	4
8	UF1828	M6 FW	7
9	UF0835	SHCS M6-1.0 x 20mm	3
10	UPM6043	SHAFT	2
11	UPM5713	SHAFT COLLAR	2
12	UF3680	M10 FW	4
13	UF3679	HHCS M10-1.5 x 20mm	4
14	UPM6142	SHUTTLE BLOCK	2
15	UPM6040	BRACKET	1
16	UF0105	M8 FW	8
17	UF3640	M8 LW	8

ITEM	PART NUMBER	DESCRIPTION	QTY
18	UF0098	SHCS M8-1.25 x 25mm	8
19	UPM6143	BACK FRAME	1
20	UF3816	M24 NUT	1
21	UF5399	FHCS M5-0.8 x 25mm	4
22	UPM5114	HUB	1
23	UF0091	FHCS M8-1.25 x 25mm	4
24	UPM5109	STEPPED SHAFT	1
25	UF5600	BHCS M6-1.0 x 12mm	1
26	UPM2206	EXTENSION SPRING	1
27	UF0062	M6 NUT	1
28	UPM8006	PIVOT ARM	1
29	UF6336	TEFLON WASHER	1
30	UPH9059	PEEL OFF ROLLER	1
31	UPH0949	GUIDE ROLLER SHAFT	1
32	UF1828	M6 FW	1
33	UF6363	M6 LW	1
34	UF4052	BHCS M6-1.0 x 50mm	2

ITEM	PART NUMBER	DESCRIPTION	QTY
35	UF5404	FHCS M5-0.8 x 16mm	4
36	UPM5111	PANCAKE	1
37	UAM0195	MANDREL HUB	1
38	UF3815	RET'G RING, ID 10	1
39	UPM4889	HNADLE	1
40	UAM0462	CROSS BAR ASSY	1
41	UF3743	M10 LW	4
42	UF0037	BHCS M5-0.8 x 16mm	1
43	UF7021	M5 LW	1
44	UF0106	M5 FW	1
45	UF0108	SPECIAL WASHER	1
46	UPM2803	ROTARY SLEEVE	1
47	UPM2539	BUSHING	1
48	UPM2471	DRAG LINK	1
49	UPM2792	DIVIDE POSITIONING PILLAR	1

# APPENDIX B

## Electrical Cabinet Assembly 1

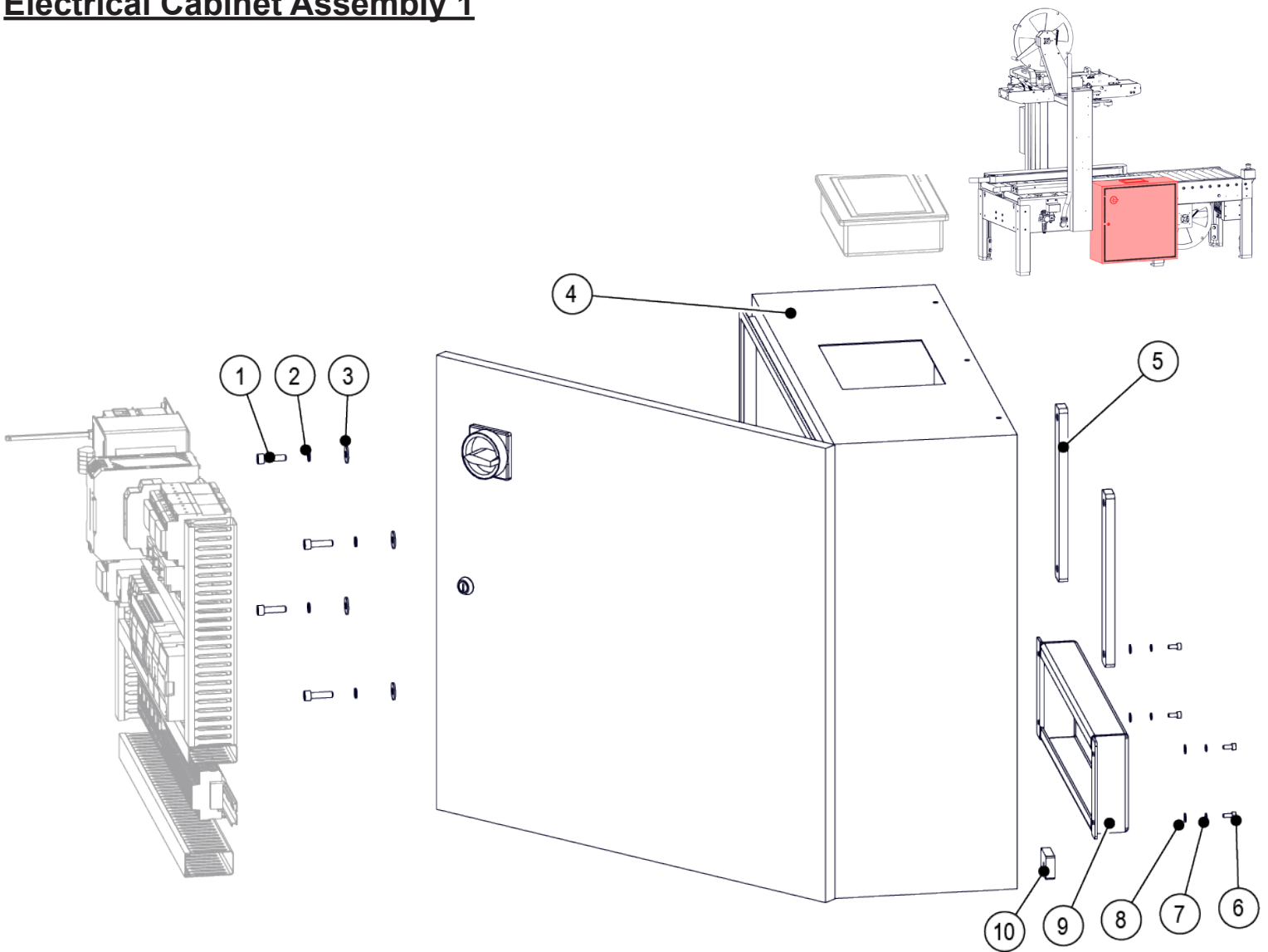

ITEM	PART NUMBER	DESCRIPTION	QTY
1	UF0099	SHCS M8-1.25 x 30mm	4
2	UF3640	M8 LW	4
3	UF0113	M8 FW	4
4	UPM6173	ELECTRICAL CABINET	1
5	UPM6174	ELEC. CAB. MOUNT BAR	2
6	UF7003	SHCS M5-0.8 x 12mm	4

ITEM	PART NUMBER	DESCRIPTION	QTY
7	UF7021	M5 LW	4
8	UF1827	M5 FW	4
9	UPM6175	ELEC. CAB. COVER	1
10	UPM6176	ELEC. CAB. GROUND BLOCK	1

# APPENDIX B

## Electrical Cabinet Assembly 2

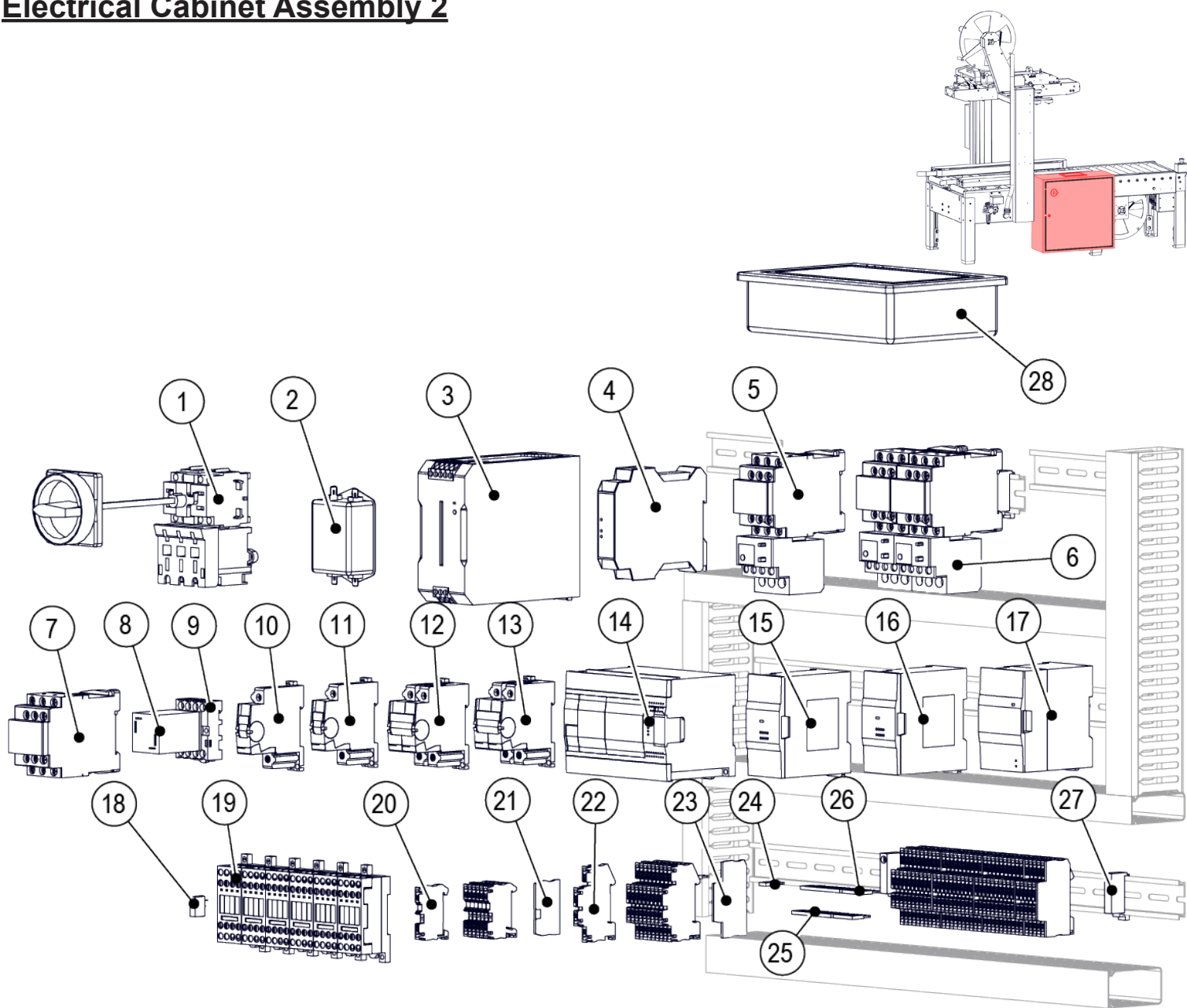

ITEM	PART NUMBER	DESCRIPTION	QTY
1	UPM6178	POWER SWITCH	1
2	UPM6186	FILTER	1
3	UPM4912	POWER SUPPLY 24V	1
4	UPM6187	SAFETY MODULE	1
5	UPM6189	ELECTROMAGNETIC CONTACTOR (AC110V)	3
6	UPM4914	MOTOR OVERLOAD RELAYS	3
7	UPM6188	ELECTROMAGNETIC CONTACTOR (DC24V)	1
8	UPM6190	AC120 RELAY, MECHANICAL INDICATOR	1
9	UPM6191	RELAY SOCKET, DIN RAIL, 8 PIN	1
10	UPM4911	MINIATURE CIRCUIT BREAKER 2A	1
11	UPM4910	MINIATURE CIRCUIT BREAKER 4A	1
12	UPM7635	MINIATURE CIRCUIT BREAKER 2p, 7A	1
13	UPM7766	MINIATURE CIRCUIT BREAKER 2p, 3A	1
14	UPM4909	PLC	1
15	UPM6183	PLC EXPANSION MODULE	1

ITEM	PART NUMBER	DESCRIPTION	QTY
16	UPM6184	PLC EXPANSION MODULE	1
17	UPM4907	PLC ANALOG OUTPUT ADD-ON CARD	1
18	UPM4915	PCB POWER RELAYS	24
19	UPM4922	RELAY OUTPUT TERMINAL BLOCK	6
20	UPM6194	TERMINAL BLOCK, GROUND	7
21	UPM6196	END COVER	1
22	UPM6193	DOUBLE LEVEL TERMINAL BLOCK	45
23	UPM6195	END COVER	5
24	UPM6197	2 PIN BRIDGE	1
25	UPM6199	10 PIN BRIDGE	2
26	UPM6198	5 PIN BRIDGE	2
27	UPM7440EV	DIN RAIL ANCHOR	4
28	UPM6177	HMI, SCREEN	1

# APPENDIX B

## Bridge Assembly

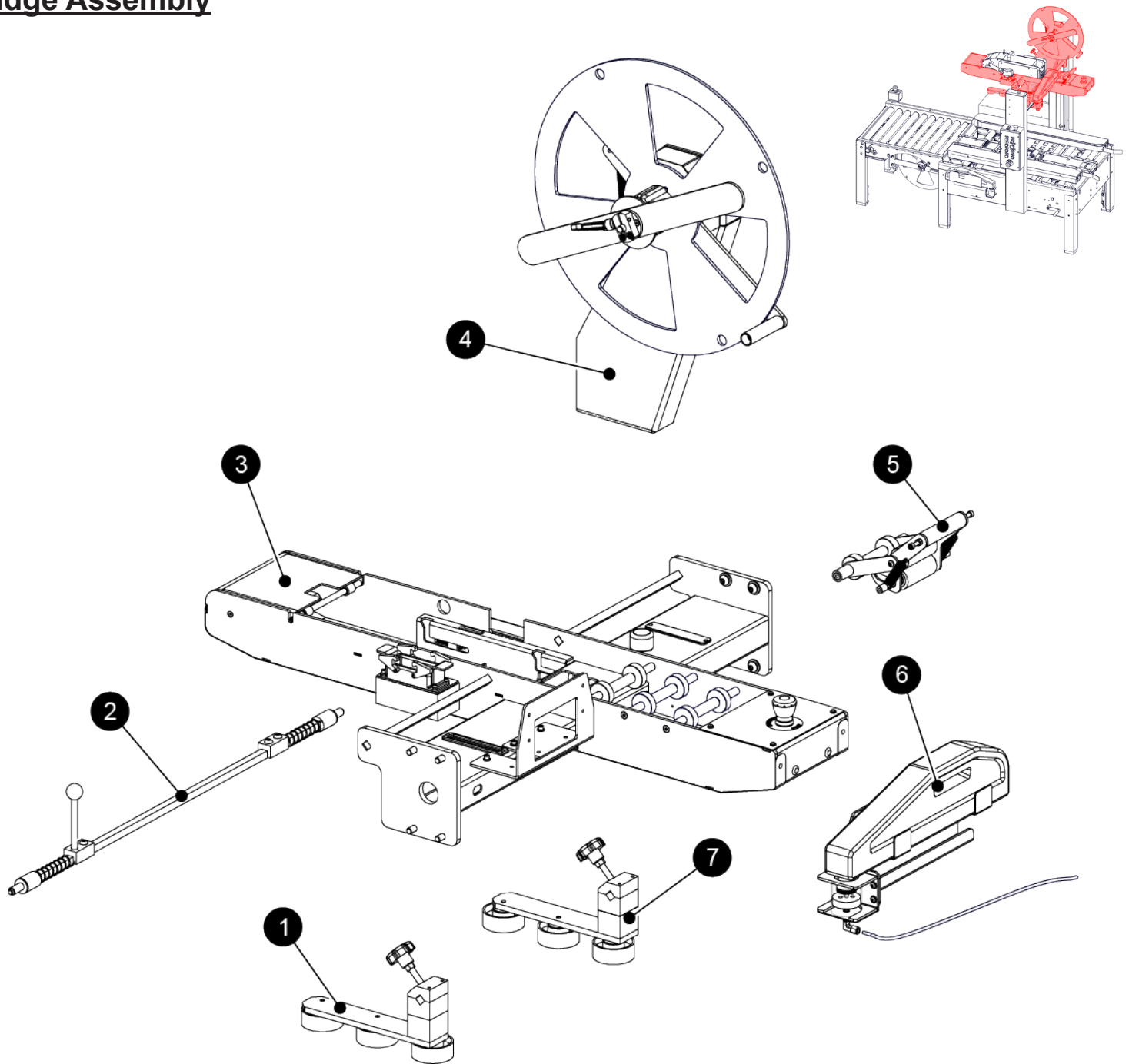

ITEM	PART NUMBER	DESCRIPTION	QTY
1	USM0823	COMPRESSION GUIDE ASS'Y R.H.	1
2	USM0391	SINGLE LOCK ASS'Y	1
3	UAM0513	BRIDGE BASE ASSEMBLY	1
4	USM7585	TOP TAPE CARRIAGE ASSEMBLY	1
5	UAM0041	CLUTCH MECHANISM USA	1
6	USM0907	TOP T.H. WATER BOTTLE ASS'Y	1
7	UAM0471	COMPRESSION GUIDE ASS'Y L.H.	1

# APPENDIX B

## Top Squeezer Assemblies

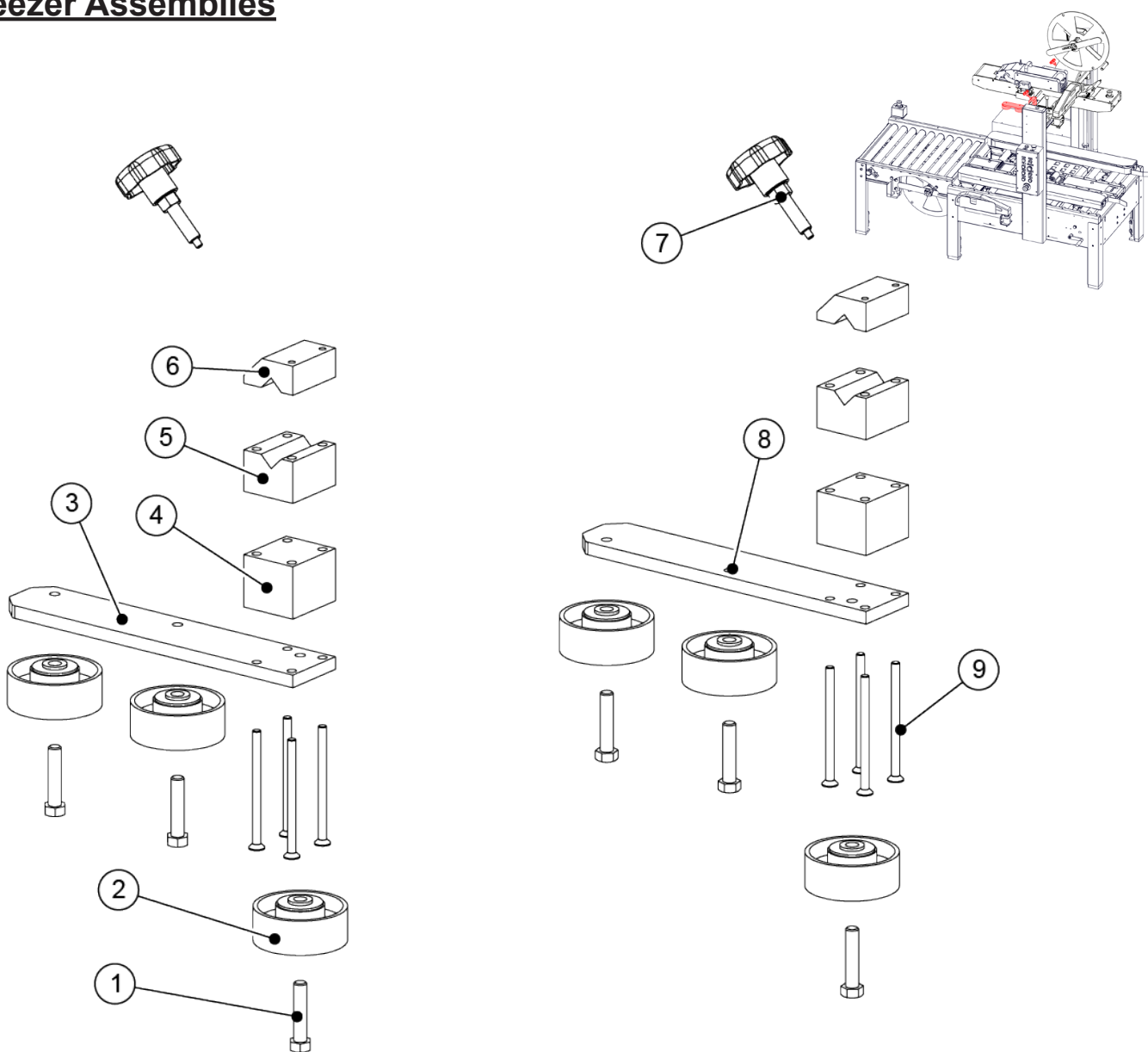

ITEM	PART NUMBER	DESCRIPTION	QTY
1	UF3024	HHCS 3/8-16 X 1.75	6
2	UPM6482	ROLLER GUIDE 2 7/8" DIA BLACK	6
3	UPM5131	WHEEL SUPPORT PLATE	1
4	UPM9740	WHEEL GUIDE SPACER	2
5	UPM3285EV	GUIDE BLOCK	2
6	UPM7538	GUIDE BLOCK TOP	2
7	UAM0376	KNOB CW	2
8	UPM5132	WHEEL SUPPORT PLATE	1
9	UF3819	FHCS M6 - 1 x 90mm	8



# APPENDIX B

## Bridge Locking Assembly

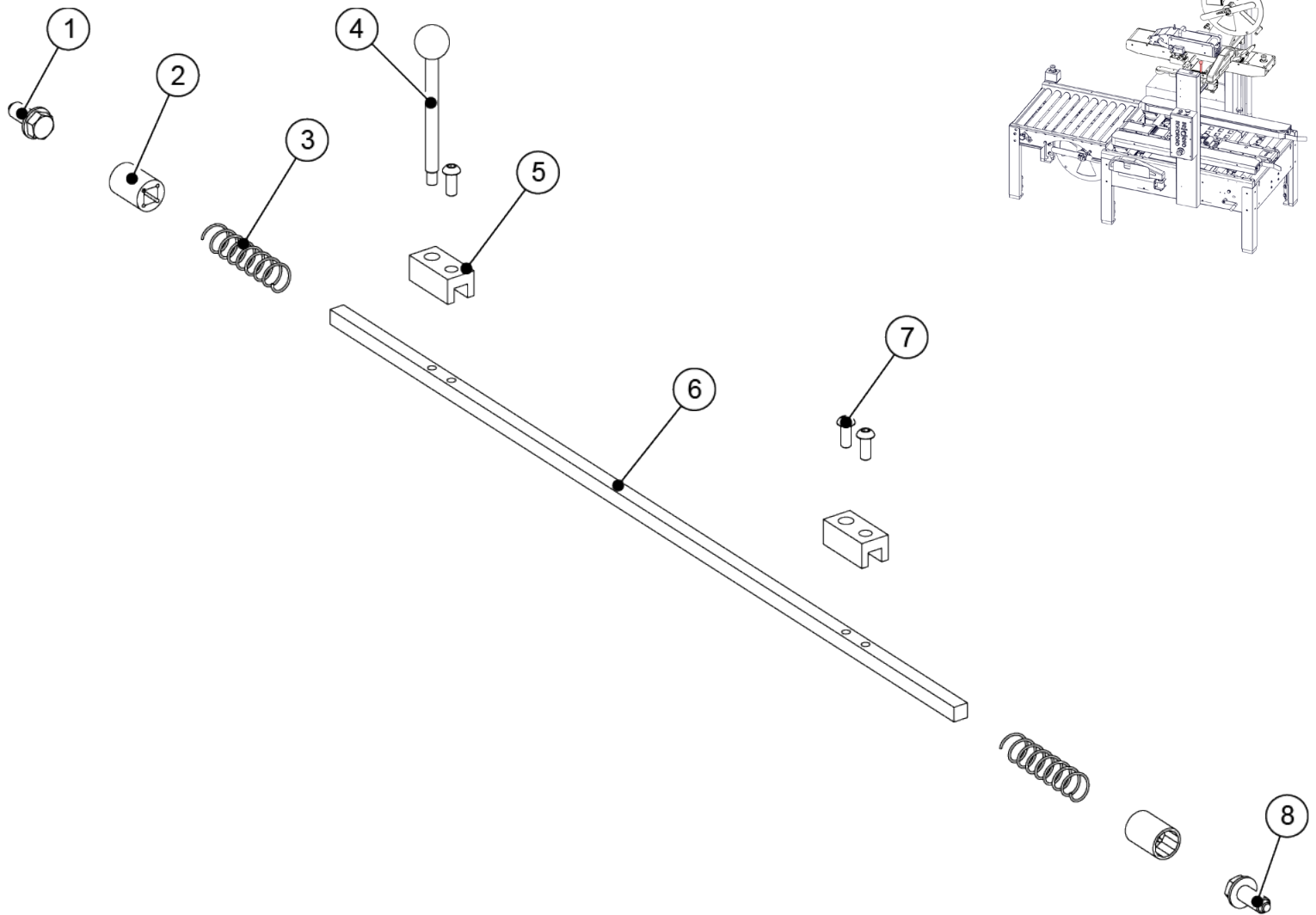

ITEM	PART NUMBER	DESCRIPTION	QTY
1	UPM0699	FLANGED SCREW 1/2-13 R.H.	1
2	UPM0703	SHORT BOX 3/4", 1/2" DR, 12 PT	2
3	UPM2184	COMPRESSION SPRING	2
4	UPM0688	SINGLE LOCKING HANDLE	1
5	UPM2866	SINGLE LOCKING BLOCK	2
6	UPM2187	SQUARE BAR 0.50	1
7	UF1318	BHCS M8-1.25x20mm	3
8	UPM0698	FLANGED SCREW 1/2-13 L.H.	1

# APPENDIX B

## Bridge Sub Assembly 1

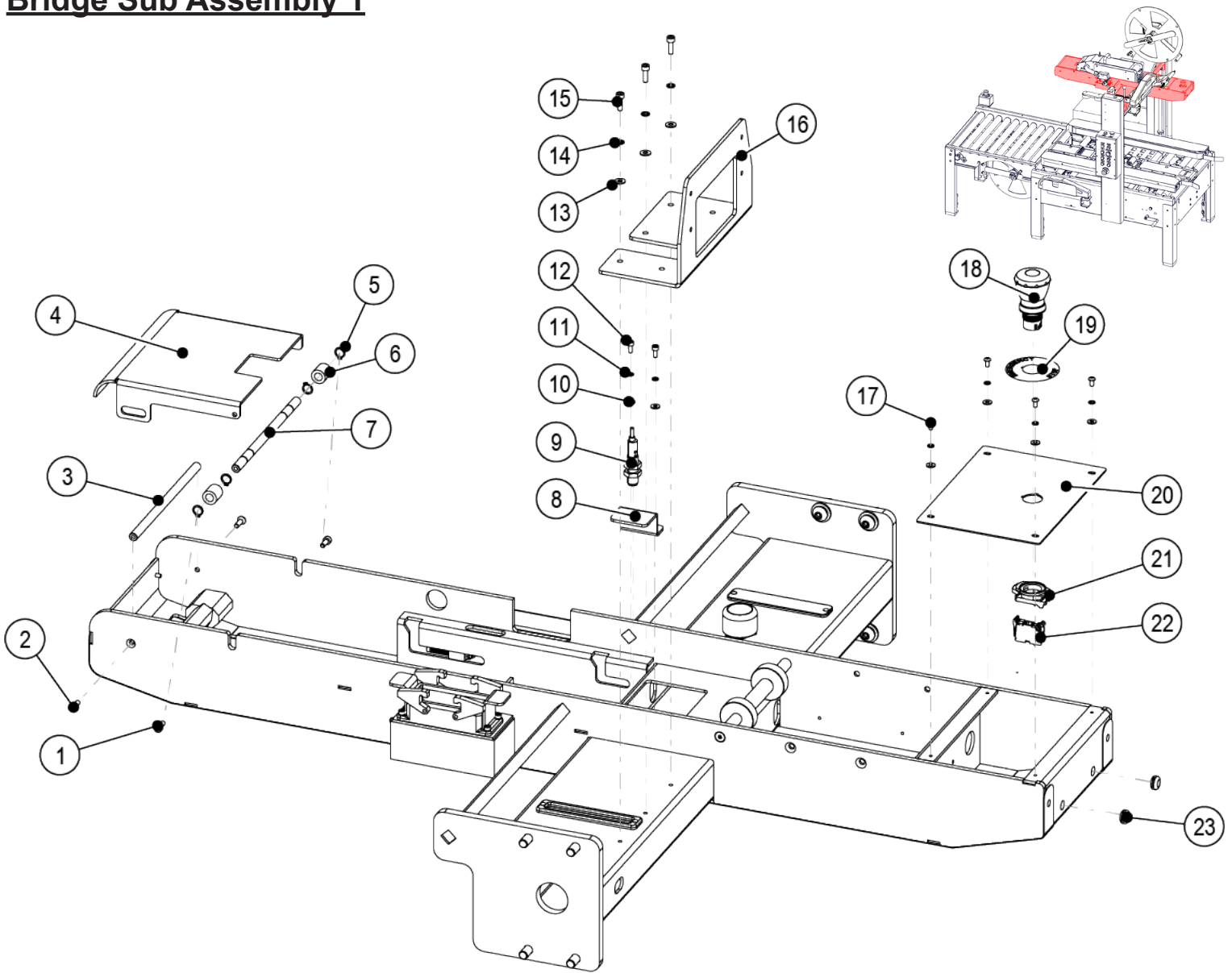

ITEM	PART NUMBER	DESCRIPTION	QTY
1	UF7003	SHCS M5-0.8×12mm	2
2	UF5404	FHCS M5-0.8×16mm	2
3	UPM5102	SHAFT, dia 9.5	1
4	UPM4989	TOP COVER	1
5	UPM6145	RETAINING RING	4
6	UPM4992	SPACER, 18L	2
7	UPM4991	SHAFT, dia 9.5, 181L	1
8	UPM4997	BRACKET	1
9	UPM5137	PHOTOELECTRIC SENSOR	1
10	UF6339	M4 FW	6
11	UF3749	M4 LW	6
12	UF9148	SHCS M4-0.7×10mm	2

ITEM	PART NUMBER	DESCRIPTION	QTY
13	UF6340	M5 FW	3
14	UF7021	M5 LW	3
15	UF3169	SHCS M5-0.8×16mm	3
16	UPM6166	BRACKET	1
17	UF3685	BHCS M4-0.7×8mm	4
18	UPM3892	EMERGENCY STOP BUTTON	1
19	UPM6045	E-STOP LABEL	1
20	UPM6167	E-STOP PLATE	1
21	UPM7630	LATCH	1
22	UPM4720	NC LATCH	1
23	UPM6146	10.9MM GROMET	2

# APPENDIX B

## Bridge Sub Assembly 2

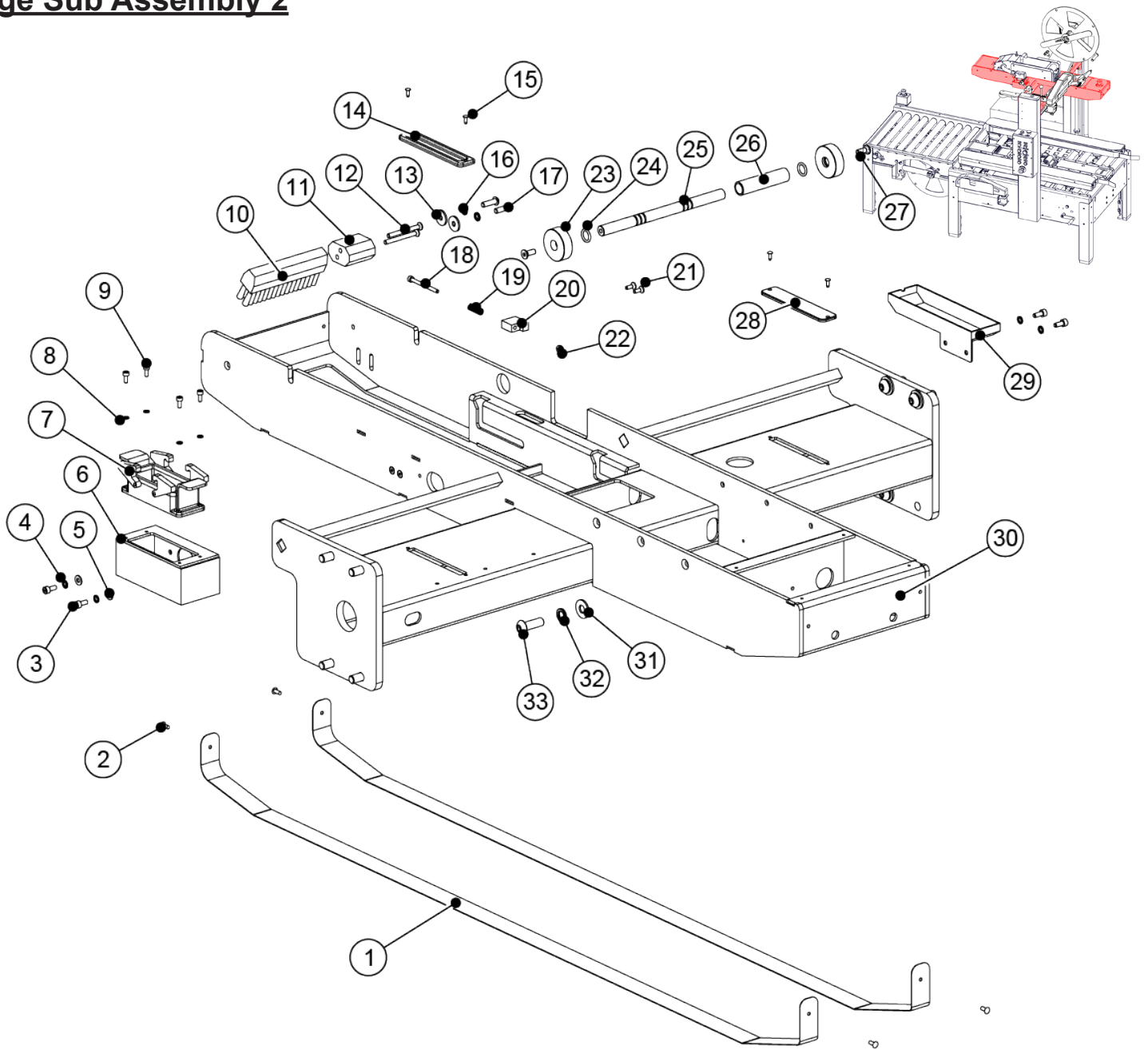

ITEM	PART NUMBER	DESCRIPTION	QTY
1	UPM5091	USA UHMW STRIP	2
2	UF3691	POP RIVET 4mm	4
3	UF7003	SHCS M5-0.8x12mm	4
4	UF7021	M5 LW	4
5	UF1827	M5 FW	2
6	UPM4980	ELECTRICAL RECEPTACLE BASE	1
7	UPM4938	RECEPTACLE CONNECTION	1
8	UF3749	M4 LW	4
9	UF9148	SHCS M4-0.7x10mm	4
10	UPH4004	BRUSH 4" TH	1
11	UPM4968	BRUSH ADAPTOR	1
12	UF0074	FHCS M5-0.8x50mm	2
13	UF0103	M6 FW, 19MM OD	2
14	UPM1011	BRIDGE COVER PLATE SLOTTED	1
15	UPM2192	BLACK PLUG	4
16	UF6363	M6 LW	2
17	UF1241EV	BHCS M6-1.0x20mm	2

ITEM	PART NUMBER	DESCRIPTION	QTY
18	UF3760	SHCS M4-0.7x50mm	2
19	UPM1068	COMPRESSION SPRING	2
20	UPM5084	SPRING SUPPORT	2
21	UF3714	FHCS M4-0.7x12mm	4
22	UF6376	LOCK-NUT	2
23	UPM5967	GUIDE ROLLER, 40OD	2
24	UPM4936	RUBBER RING	2
25	UPM4993	SHAFT, dia 12.7, 189L	1
26	UPM4933	ROLLER, dia 17, 72L	1
27	UF1192	FHCS M6-1.0x16mm	2
28	UPM1008	BRIDGE PLATE COVER	1
29	UPM4990	OVER FLOW TRAY	1
30	UPM6165	BRIDGE WELDMENT	1
31	UF3680	M10 FW	8
32	UF3743	M10 LW	8
33	UF4310	BHCS M10-1.5x30mm	8

# APPENDIX B

## Top Tape Mandrel Assembly

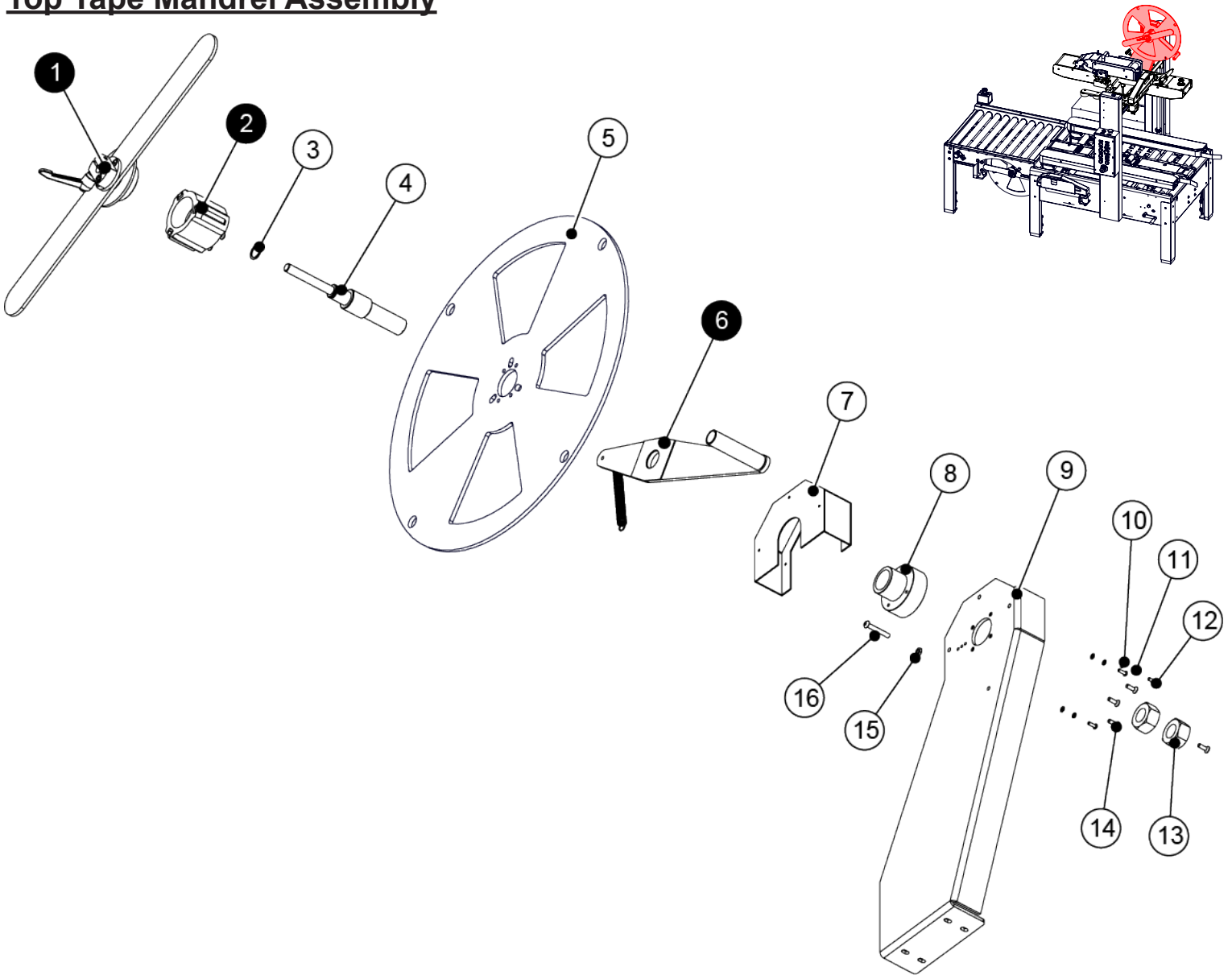

ITEM	PART NUMBER	DESCRIPTION	QTY
1	UAM0462	CROSS BAR ASSEMBLY	1
2	UAM0195	MANDREL HUB	1
3	UF3815	RET'G RING, ID 10	1
4	UPM5109	STEPPED SHAFT	1
5	UPM5111	PANCAKE	1
6	UAM0479	DANCER ARM ASSEMBLY	1
7	UPM5200	BACK COVER	1
8	UPM9901	HUB USA	1
9	UPM5201	MANDREL FRAME	1

ITEM	PART NUMBER	DESCRIPTION	QTY
10	UF6339	FW M4	3
11	UF3749	M4 LW	3
12	UF3649	BHCS M4-0.7 x 12mm	3
13	UF3816	HEX NUT M24 - 1.5	2
14	UF3277	FHCS M5-0.8 x 16 mm	4
15	UF3361	JAM NUT M6	1
16	UF4503	BHCS M6-1 x 40mm	1

# APPENDIX B

## Cross Bar Assembly

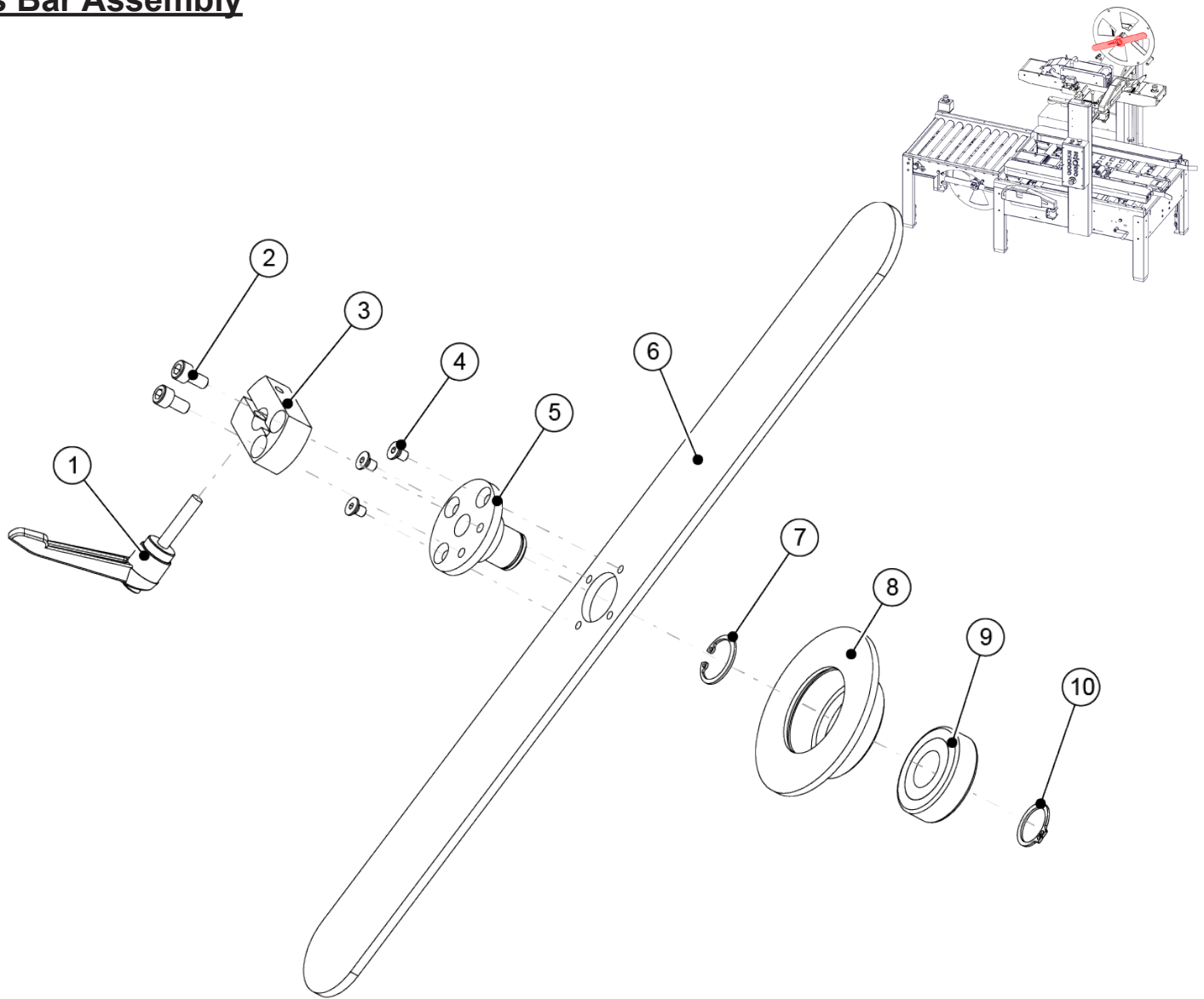

ITEM	PART NUMBER	DESCRIPTION	QTY
1	UPM4889	HANDLE	1
2	UF3183	SHCS M6-1 x 12mm	2
3	UPM5107	CLAMPING	1
4	UF7024	FHCS M5-0.8 x 8 mm	3
5	UPM5106	RETAINER	1
6	UPM5108	CROSS BAR	1

ITEM	PART NUMBER	DESCRIPTION	QTY
7	UF3814	INTERNAL RET' RING	1
8	UPM5104	FLANGE MANDREL	1
9	UPM4888	BALL BEARING	1
10	UF3815	RET'G RING, ID 10	1

# APPENDIX B

## Tape Mandrel Assembly

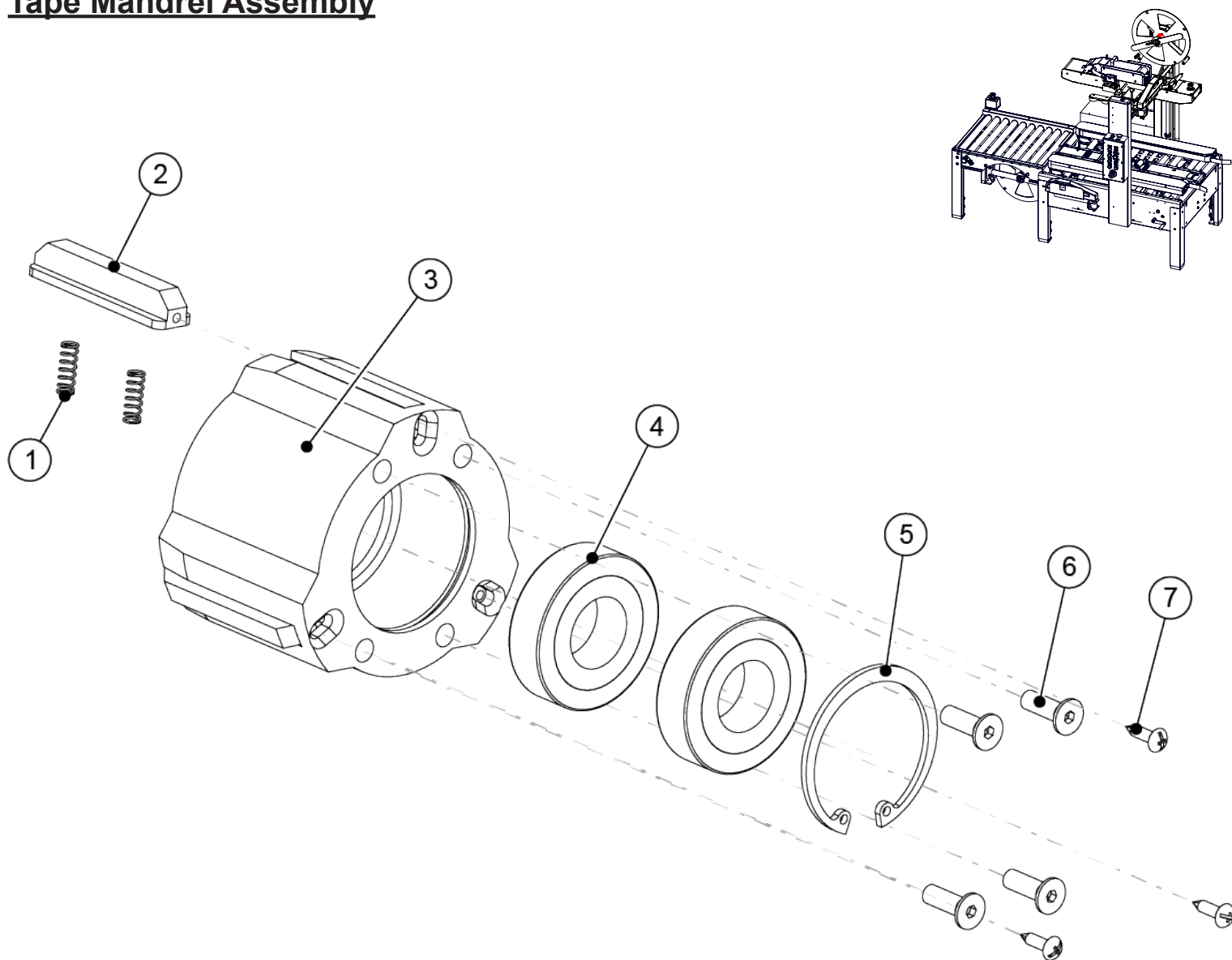

ITEM	PART NUMBER	DESCRIPTION	QTY
1	UPH1468	COMPRESSION SPRING	6
2	UPM5074	SPRAG	3
3	UPM5073	MANDREL HUB	1
4	UPM0324	BEARING	2
5	UF0101	INTERNAL RETAINING RING, 42mm	1
6	UF5404	FHCS M5-0.8×16mm	4
7	UF3820	BHCS M3-0.5 SELF TAPPING	3

# APPENDIX B

## Dancer Bar Assembly

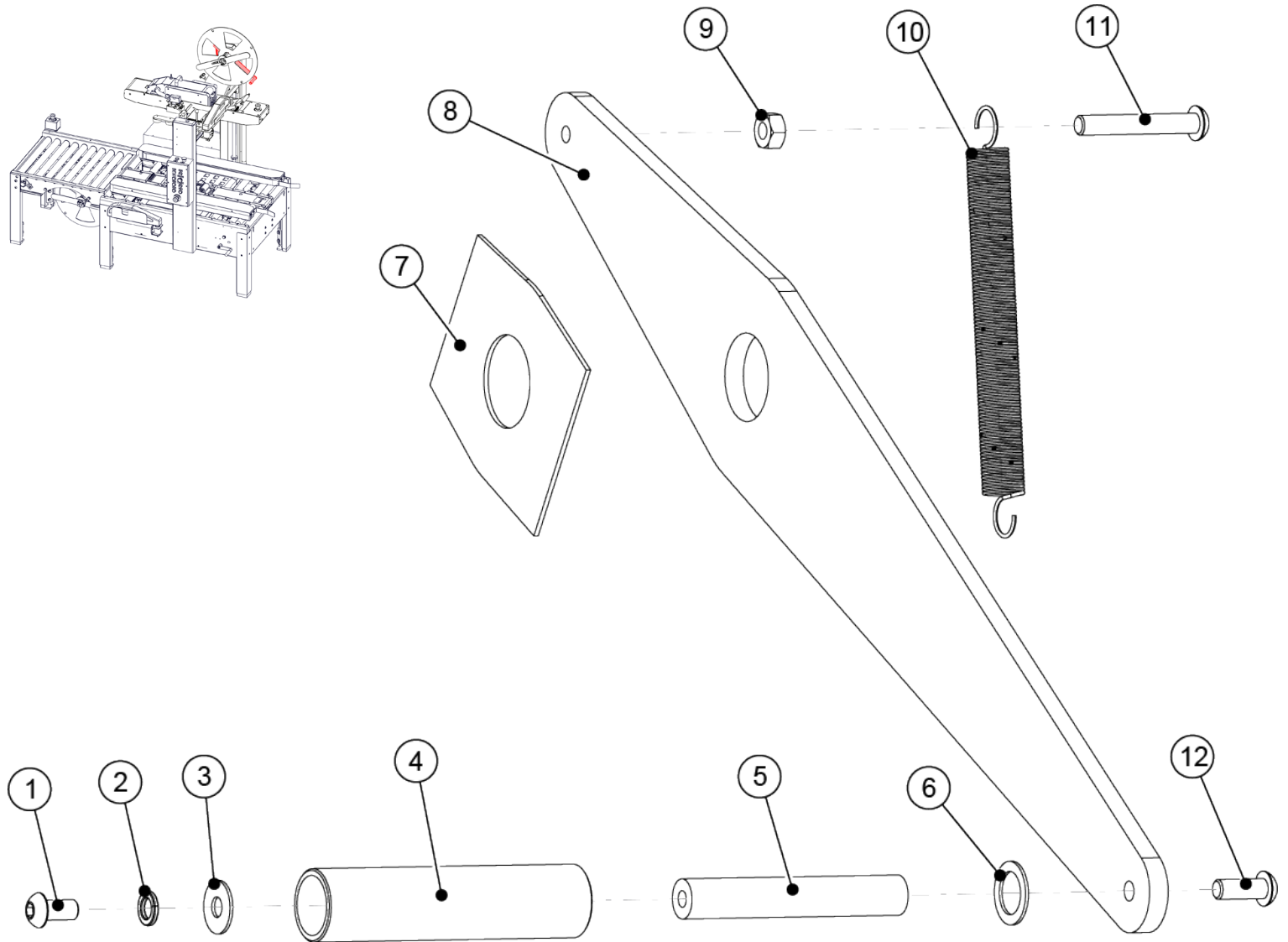
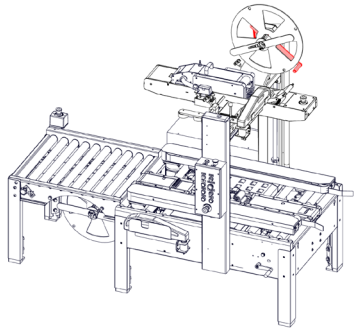

ITEM	PART NUMBER	DESCRIPTION	QTY
1	UF5600	BHCS M6-1.0×12mm	1
2	UF6363	M6 LW	1
3	UF1828	M6 FW	1
4	UPH9059	PEEL OFF ROLLER	1
5	UPH0949	GUIDE ROLLER SHAFT	1
6	UF6336	F.W. PTFE, 13 x 19 x 1 mm	1
7	UPM9802	BREAK PAD	1

ITEM	PART NUMBER	DESCRIPTION	QTY
8	UPM6238	PIVOT ARM	1
9	UF3361	M6-1.0-HNR	1
10	UPM4498	EXTENSION SPRING	1
11	UF4503	BHCS M6-1.0×40mm	1
12	UF1250EV	BHCS M6-1.0×16mm	1

# APPENDIX B

## Top Clutch Assembly

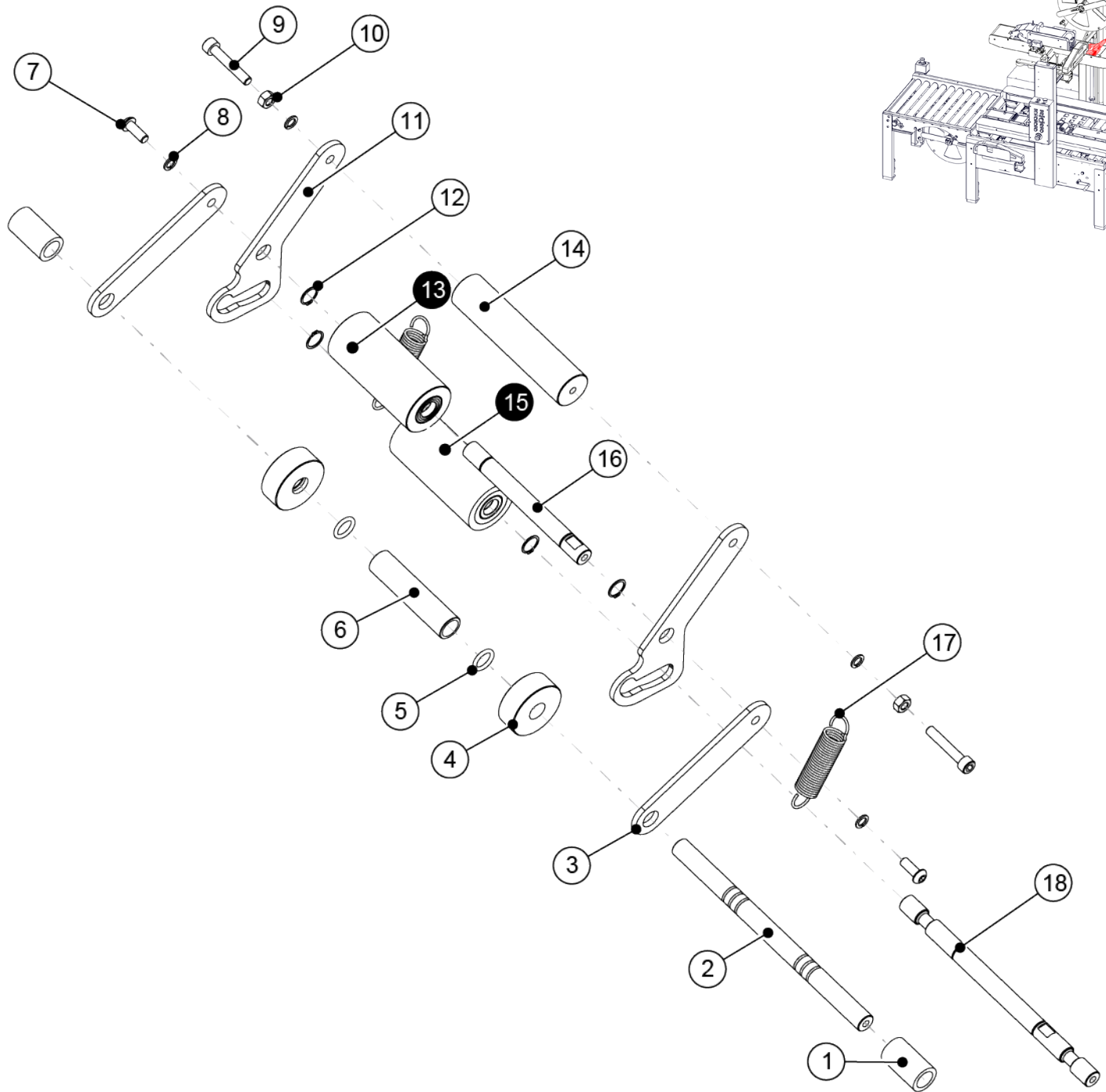

ITEM	PART NUMBER	DESCRIPTION	QTY
1	UPM5917	CM SPACER	2
2	UPM5919	CM PIVOT SHAFT	1
3	UPM5908	CM PIVOT ARM	2
4	UPM2485	ADJUSTMENT RING	2
5	UPM2492	O RING	2
6	UPM4667	IDLER ROLLER	1
7	UF6414	BHCS M6-1 x 16mm	2
8	UF6363	M6 LW	4
9	UF0850	SHCS BB M6-1 X 35mm	2
10	UF3637	M6-1.0 HNR	2

ITEM	PART NUMBER	DESCRIPTION	QTY
11	UPM5910	CM CLAMP ARM	2
12	UF6300	RETAINING RING 12mm	4
13	UAM0034	PINCH ROLLER ASSEM	1
14	UPM5909	CM CLAMP ARM HANDLE	1
15	UAM0033	CLUTCH ROLLER ASSEM	1
16	UPM5907	CM PINCH ROLLER SHAFT	1
17	UPM5999	CM SPRING	2
18	UPM5920	CM CLUTCH ROLLER SHAFT USA	1



# APPENDIX B

## Top Water Assembly

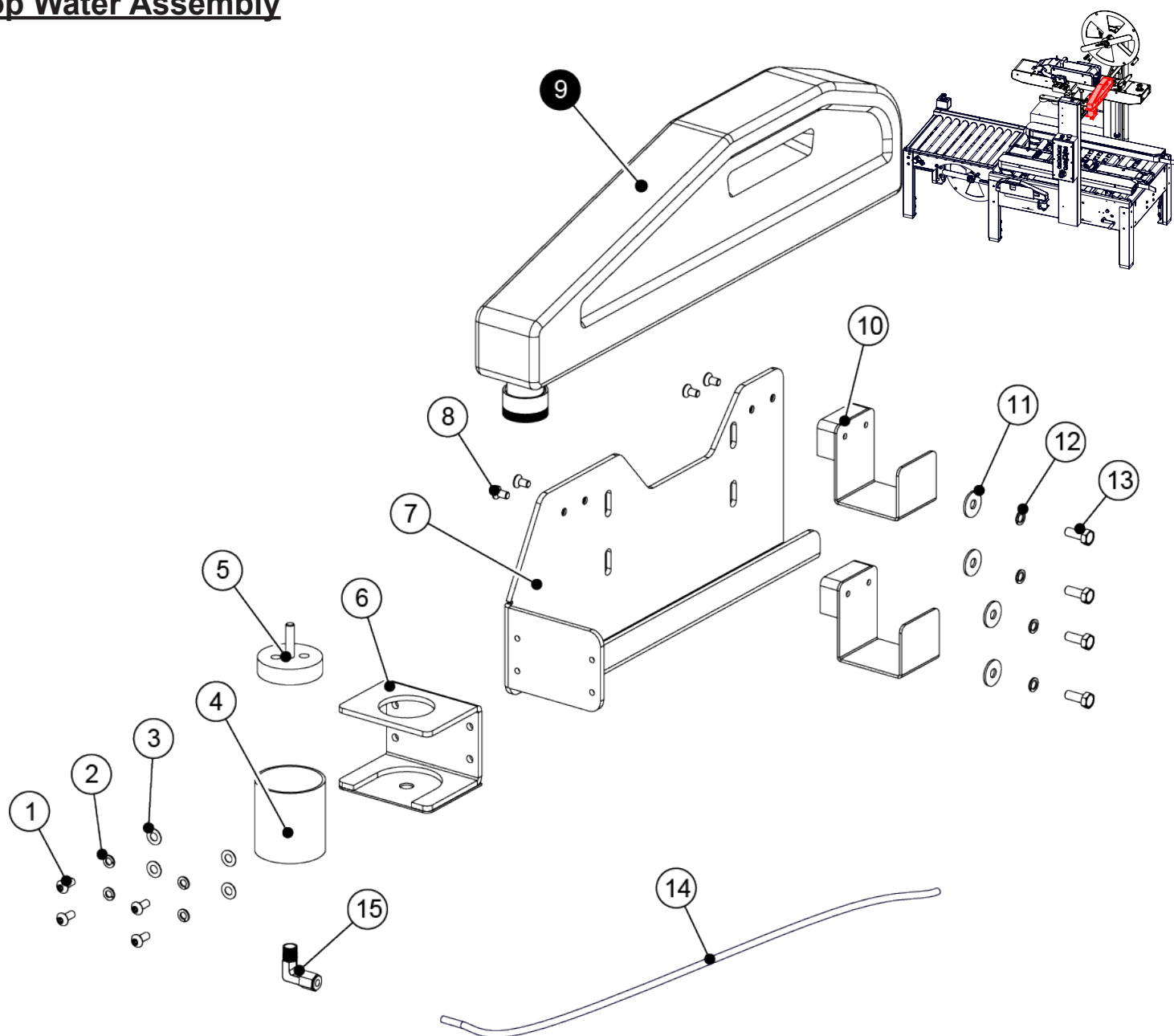

ITEM	PART NUMBER	DESCRIPTION	QTY
1	UF7011	BHCS M5 X 0.8 X 12mm	4
2	UF7021	M5 LW	4
3	UF4071	6 x 12 x 0.5 FW	4
4	UPM4946	RESERVOIR CUP	1
5	UPM5901	PLUNGER	1
6	UPM4945	CUP HOLDER	1
7	UPM5116	FRAME	1
8	UF3262	FHCS M5-0.8 x 10 mm	4

ITEM	PART NUMBER	DESCRIPTION	QTY
9	WST1014	WATER BOTTLE & CAP	1
10	UPM5120	WT BOTTLE HOLDER	2
11	UF1890	1/4 x 3/4 x 1/16 FW	4
12	UF6411	M6 LW	3
13	UF3751	HHCS M6-1.0 x 16mm	4
14	UPM5543	WATER TUBE 22in (559mm)	1
15	UPM5151	ELBOW FITTING	1

